

Modular Assembly System

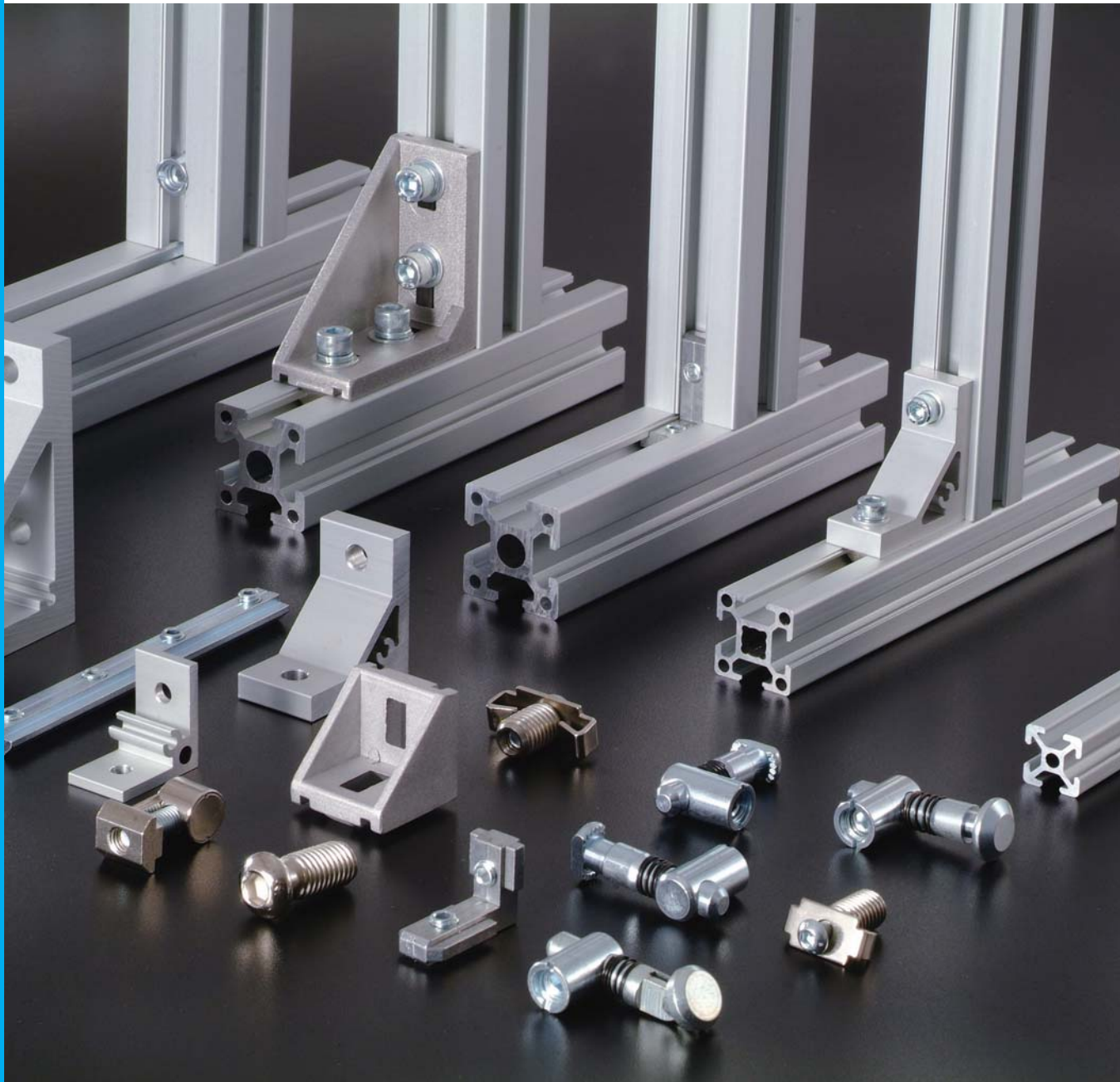

Modular Assembly System

Version **7.4**



Profession Devotion Keep Improving

Made in China;
Higher quality at unbeatable price;
Shipped directly pre-assembled to customers;
Converting any original design to MAT design, free of charge.

Try once, and you will never change!!!

What's inside...

Assembly Technology

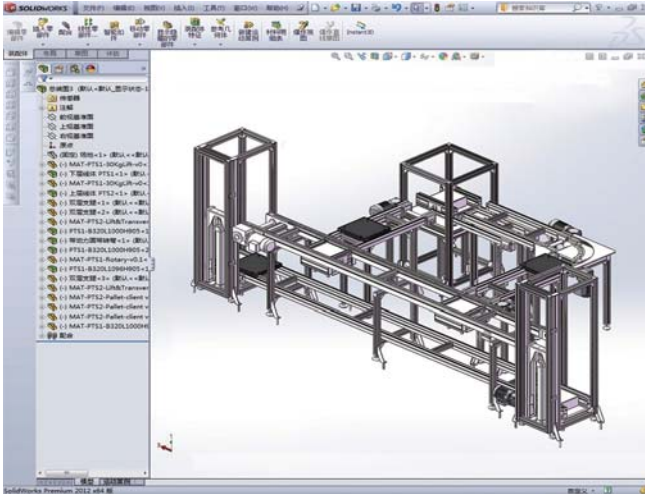

Planning Software

- Complete product info
- CAD library
- Quick & Easy configurator
- Calculation of profile deflection
- Drawing conversion for profiles
- Layout Designer for fast, easy planning



On-time, rapid delivery

- Availability of all components
- Pre-assembled modules, complete frames
- Prompt shipping and exemplary delivery reliability



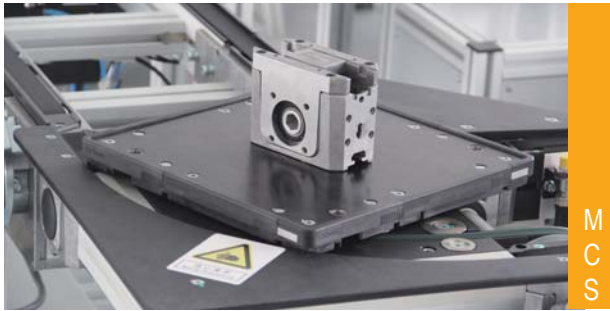

Modular Conveyor System(MCS) is mainly for pallet conveyor system. This system is widely used in new energy, car component production, pharmaceutical, electronics, tobacco, packing and other industries.



Modular Assembly System (MAS) is composed of industrial aluminum profiles and accessories. You can quickly find a solution for all tasks with the complete specification and variety of accessories from MAT.



Machine Guard System (MGS) is designed for customers with advanced guarding need. The special design of guarding profiles offer better appearance and unique fastening elements brings faster and safer connections.



Stair and Platform System (SPS) is commonly used for overpass bridges over machinery and equipment. The assembly can be realized easily by simply fastening screws without any machine work. The system is very easy and convenient to use.



Tubular Framing System (TFS) is a flexible modular system composed of special profile tubes and accessories to build a diverse range of flow racks and material shuttles. TFS is simple and quick to use, also low cost.





Modular Conveyor System

Modular Assembly System

Machine Guard System

Stair and Platform System

Tubular Framing System



Modular Assembly System---
safe, quick, reliable

Use our comprehensive range
to effectively cut working hours and costs.

- Short planning times
- Faster construction
- Highly flexible conversion and extension options
- Reusable components
- Available worldwide



Machine guard frame for conveying equipment



Special profile for clean room frame



Lifting equipment frame 升降设备框架



Machine guard frame



Working table





Protective barriers for machine



Protective barriers for robot

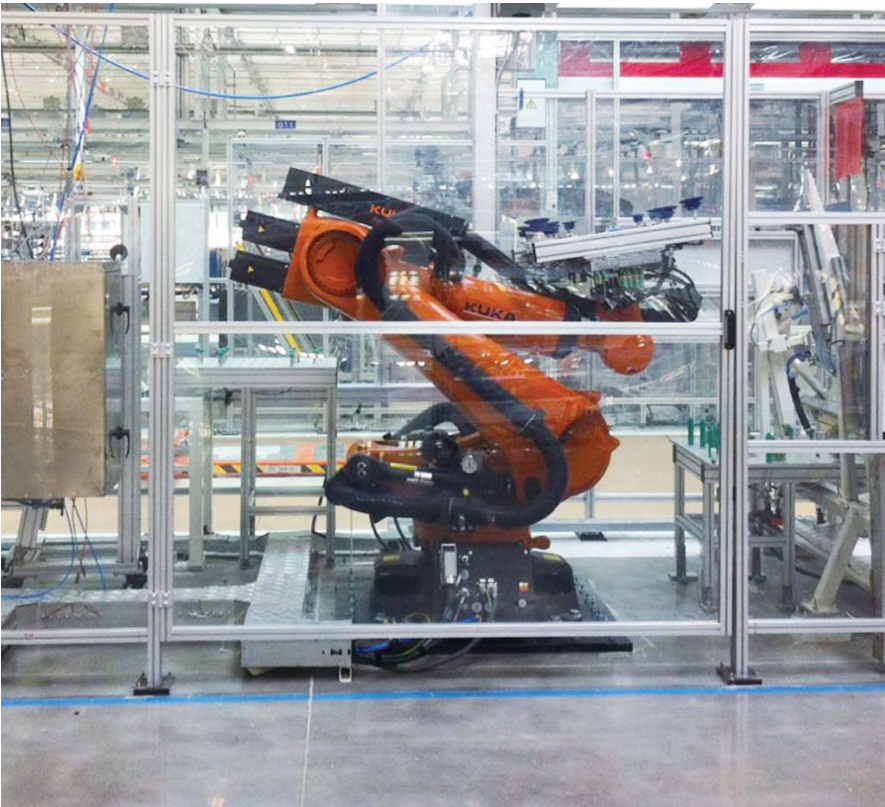

Protective barriers for robot



Protective barriers for machine



Protective barriers for car assembly line

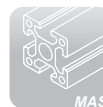



Bridge for Sorting Machine



Bridge for Sorting Machine



Platform for Aerospace Equipment



Bridge for Sorting Machine



Bridge for Sorting Machine



Maintenance Platform



Bridge for Sorting Machine



Maintenance Platform



Bridge for Sorting Machine



Arched Stairs for Aerospace Equipment



1 Aluminum Profile



P. 1-06...



P. 1-07...



P. 1-08...



P. 1-11...



P. 1-17...



P. 1-21...



P. 1-22...



P. 1-23...



P. 1-24...



2 Fastening Elements



P. 2-02...



P. 2-03...



P. 2-04...



P. 2-05...



P. 2-06...



P. 2-07...



P. 2-08...



3 Connecting Elements



P. 3-03...



P. 3-07...



P. 3-12...



P. 3-31...



P. 3-32...



P. 3-34...



P. 3-40...



P. 3-41...



P. 3-42...



P. 3-43...



P. 3-44...



4 Profile Accessories



P. 4-02...



P. 4-04...



5 Floor Elements



P. 5-02...



P. 5-03...



P. 5-04...



P. 5-07...



P. 5-08...



P. 5-10...



P. 5-11...



P. 5-14...



P. 5-15...



P. 5-16...



P. 5-17...



P. 5-18...



6 Panel Installation Elements



P. 6-02...



P. 6-03...



P. 6-04...



P. 6-05...



Door and Window Elements



P. 7-02...



P. 7-03...



P. 7-04...



P. 7-05...

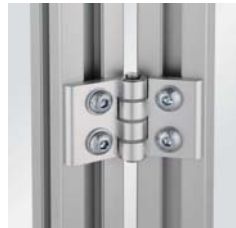

P. 7-06...



P. 7-09...



P. 7-10...

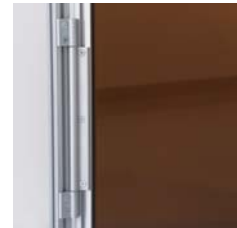

P. 7-11...



P. 7-12...



P. 7-13...



P. 7-14...



P. 7-16...



P. 7-17...



Additional Accessories



P. 8-02...



P. 8-03...



P. 8-04...



P. 8-05...



P. 8-07...



P. 8-09...



1.11-1.41

Strut Profile

Angle Profile

Conduit Profile

Aluminum Profile



P. 1-06



P. 1-23



P. 1-24



Technical Data

Extruded aluminum profile as per GB5237-2008, surface satin anodized.
Standard length of delivery profiles are: 6000mm for delivery inside China, 5800mm for international shipment.

Tensile Strength	min.185N/mm ²
Yield Strength	min.145N/mm ²
Elongation	8%(T≤3.2mm) or 10%(T>3.2~25.0mm)
E-Module	approx.70,000N/mm ²
Brinell Hardness	HB 75 2.5/187.5
Coat Thickness	≥11μ

Bending Strength

For deflection calculation, refer to formulas as below:

- f (mm): Deflection /
- F (N): Type of load
- L (mm): Profile length /
- I (cm⁴): Moment of inertia
- E (N/mm²): Modular of elasticity

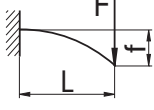
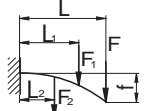
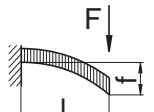
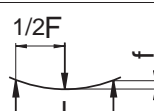
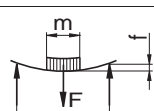
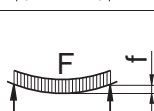
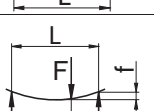
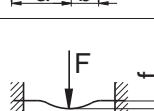
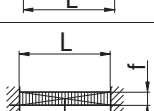
1		$f = \frac{F \cdot L^3}{3E \cdot I \cdot 10^4}$
2		$f = \frac{F \cdot L^3 + F_1 \cdot L_1^2 \cdot L + F_2 \cdot L_2^2 \cdot L}{3E \cdot I \cdot 10^4}$
3		$f = \frac{F \cdot L^3}{8E \cdot I \cdot 10^4}$
4		$f = \frac{F \cdot L^3}{48E \cdot I \cdot 10^4}$
5		$f = \frac{F \cdot L^3}{\left(48 + \frac{29m}{L}\right) \cdot E \cdot I \cdot 10^4}$
6		$f = \frac{5F \cdot L^3}{384E \cdot I \cdot 10^4}$
7		$f = \frac{F \cdot a^2 \cdot b^2}{3E \cdot I \cdot 10^4 \cdot L}$
8		$f = \frac{F \cdot L^3}{192E \cdot I \cdot 10^4}$
9		$f = \frac{F \cdot L^3}{384E \cdot I \cdot 10^4}$

Approximate determination of deflection

Determinations of deflection:

1. Type of load F in N
F(N)
2. Profile length L in mm
L(mm)
3. Move cross point on the diagonal
4. Moment of inertia of selected profile I in cm⁴
I(cm⁴)
5. Cross point with the diagonal to be vertically extended to the bottom
6. Deflection f for the specific "Type of load" in mm
f(mm)

Example:

1. F=2,000N
 2. L=1,000mm
 3. Move cross point on the diagonal
 4. I=80.8cm⁴ for profile 40x80, 6EH
(1.11.40.040080.06H)
 5. Cross point with the diagonal to be vertically extended to the bottom
 6. Deflection f for the specific "Type of load" in mm
f(mm)
- Type of load 1: f=9.5mm
f=9.5mm
- Type of load 4: f=0.6mm
f=0.6mm
- Type of load 8: f=0.15mm
f=0.15mm

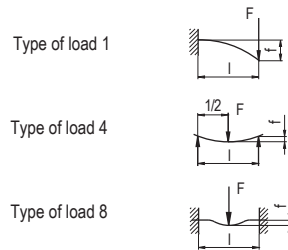
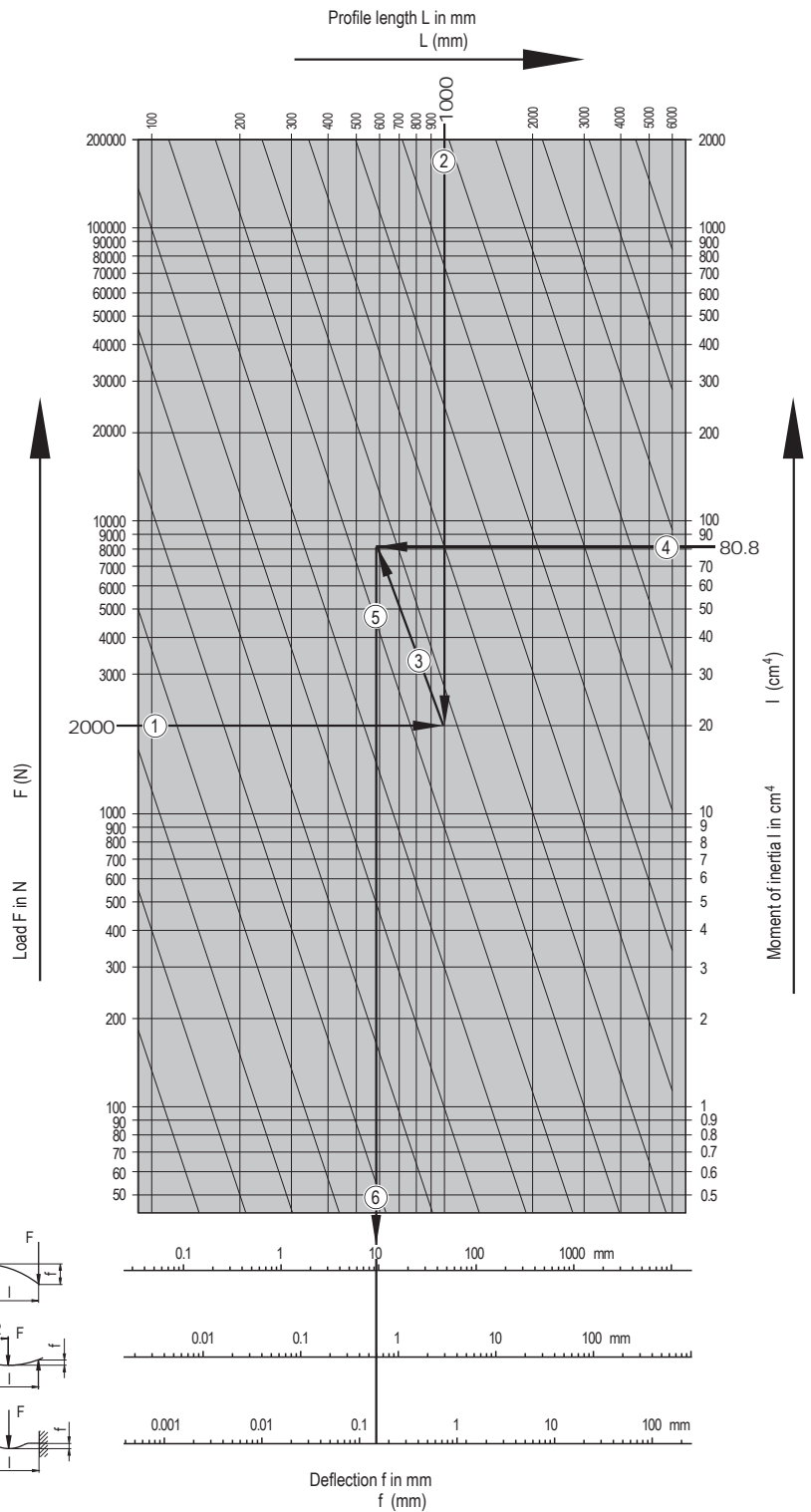

Profile Tolerance

Flatness tolerance

The flatness tolerance w (angular tolerance) refers to unequal sides to the shorter side of the angle, i.e. it is measured from the longer side.

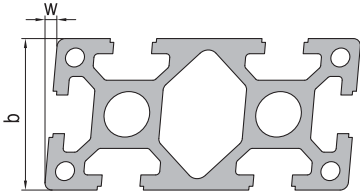

b(mm)	w(mm)
≤40	0.3
>40~80	0.5
>80~180	1.0

Straightness tolerance

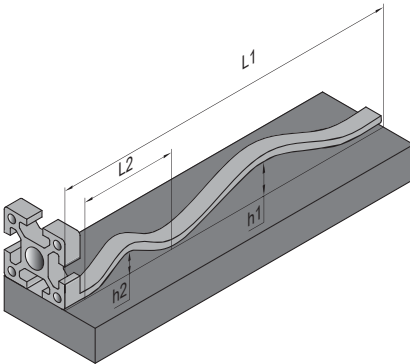

Putting the profile on a horizontal surface, the max bending height $h2$ in any length of 30mm ($L2$) is not more than 0.3mm ($L2=300mm$, $h2 \leq 0.3mm$). Refer to the following table for the bending height $h1$ of the full length profile ($L1$).

L1(m)	1	2	3	4	5	6
$h1$ (mm)	0.7	1.4	2.1	2.8	3.5	4.2

Twist tolerance

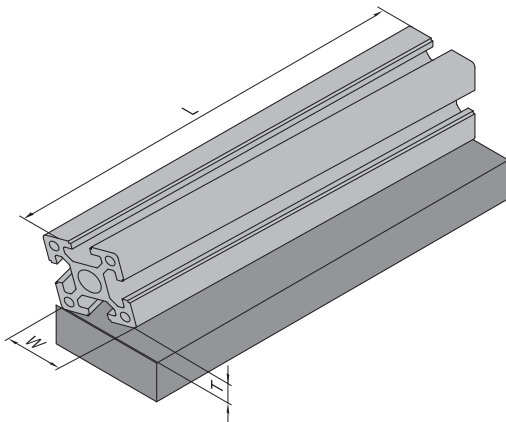

Putting the profile on a horizontal surface, if the end tilts due to twist, the twist height (T) could be calculated according to the formula below:

W(mm)	T(mm)	
	L≤1m	L>1m
≤40	0.052xW	0.123xW
>40~80	0.026xW	0.087xW
80~180	0.017xW	0.052xW

T Slot Symbol

Parts compatible with T slot symbolized and incompatible with faded symbolized as below.

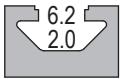
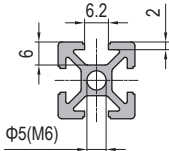
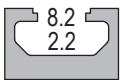
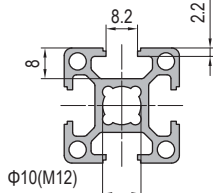
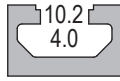
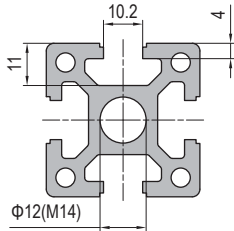
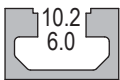
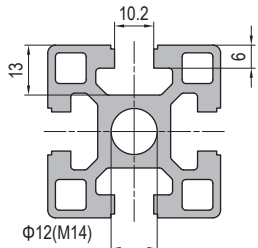

T Slot Symbol	Cross Section	Core Hole Φ	Slot Width	Slot Depth	Wall Thickness	Profile Group
		5.0	6.2	6.0	2.0	PG15 PG20
		10.0	8.2	8.0	2.2	PG30
		12.0	10.2	11.0	4.0	PG40
		12.0	10.2	13.0	6.0	PG45 PG50 PG60

Machining Symbol

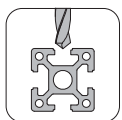

Drilling

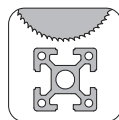

Angle cutting

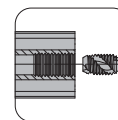

Thread tapping

Strut Profile PG15



15x15 2 slots



15x30 3 slots

Strut profile PG15 featuring 6mm T-slot is designed for constructing light weight assemblies.

15x15 2 slots

15x30 3 slots

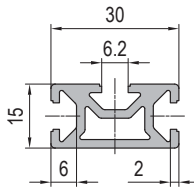
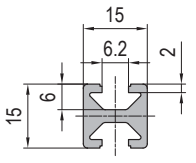

Description	Moment of Inertia $I_x(\text{cm}^4)$	Moment of Inertia $I_y(\text{cm}^4)$	Moment of Resistance $W_x(\text{cm}^3)$	Moment of Resistance $W_y(\text{cm}^3)$	Mass (kg/m)	Part No.
Strut Profile PG15 15x15 2 slots	0.2	0.4	0.3	0.5	0.4	1.11.15.015015.02
Strut Profile PG15 15x30 3 slots	0.7	1.8	0.8	1.2	0.6	1.11.15.015030.03

Connector selection



Angle Profile Bracket P. 3-12



Inner Bracket P. 3-31



Linear Bar Connector P. 3-32



Strut Profile PG20

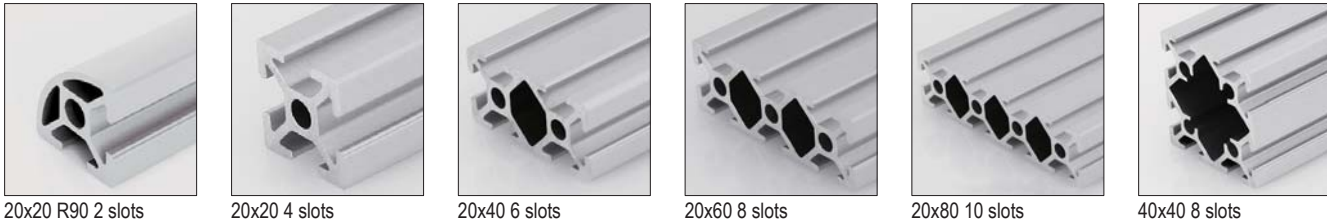

Strut profile PG20 featuring 6mm T-slot is designed for constructing light weight assemblies.

20x20 R90 2 slots

20x20 4 slots

20x40 6 slots

20x60 8 slots

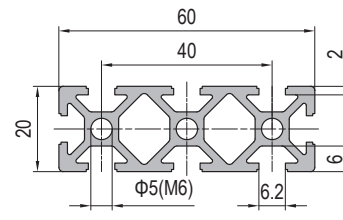
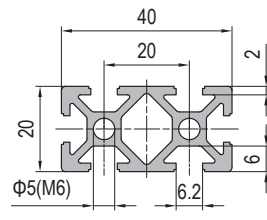
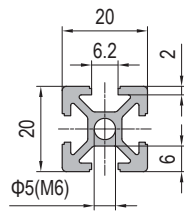
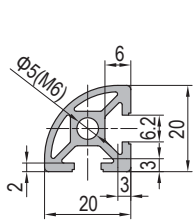

20x80 10 slots

40x40 8 slots

Connector selection

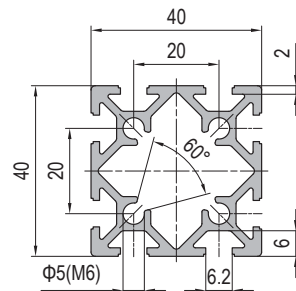
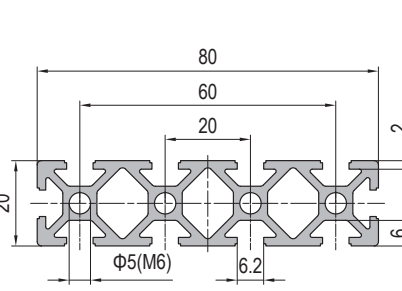

Die Cast Bracket P. 3-07



Angle Profile Bracket P. 3-12



Inner Bracket P. 3-31



Linear Bar Connector P. 3-32

Description	Moment of Inertia	Moment of Inertia	Moment of Resistance	Moment of Resistance	Mass (kg/m)	Part No.
	$I_x(\text{cm}^4)$	$I_y(\text{cm}^4)$	$W_x(\text{cm}^3)$	$W_y(\text{cm}^3)$		
Strut Profile PG20 20x20 R90 2 slots	0.6	0.6	0.5	0.5	0.45	1.11.20.020020.R90.02
Strut Profile PG20 20x20 4 slots	0.8	0.8	0.8	0.8	0.5	1.11.20.020020.04
Strut Profile PG20 20x40 6 slots	1.4	5.1	1.4	2.5	0.9	1.11.20.020040.06
Strut Profile PG20 20x60 8 slots	2.0	15.8	2.0	5.3	1.3	1.11.20.020060.08
Strut Profile PG20 20x80 10 slots	2.6	35.9	2.6	9.0	1.7	1.11.20.020080.10
Strut Profile PG20 40x40 8 slots	8.9	8.9	4.5	4.5	1.3	1.11.20.040040.08



Strut Profile PG30



15x90 7 slots



30x30 R45 2 slots

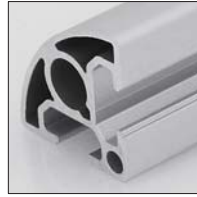

30x30 R90 2 slots



30x30 2 slots Type A



30x30 2 slots Type B



30x30 3 slots



30x30 4 slots Light



30x30 4 slots



30x60 6 slots



30x90 8 slots



30x120 10 slots



30x150 12 slots



60x60 8 slots



60x60 L 8 slots



60x120 12 slots

Strut profile PG30 featuring 8mm T-slot is designed for constructing medium weight assemblies such as machine structure frame, trolley, work station, partition and display frames etc.

Connector selection



Anchor Connector P. 3-03



Die Cast Bracket P. 3-08



Angle Profile Bracket P. 3-15



Inner Bracket P. 3-31



Linear Bar Connector P. 3-32



Screw Connector P. 3-42



Strut Profile PG30

15x90 7 slots

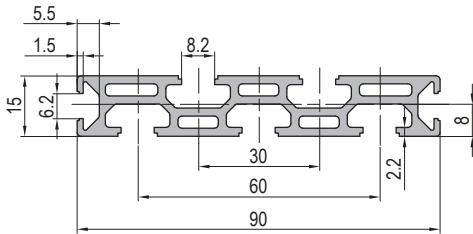

30x30 R45 2 slots

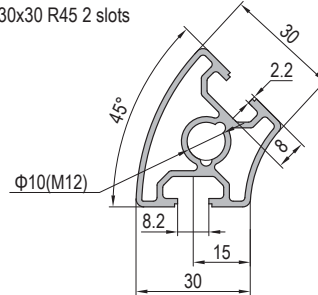

30x30 R90 2 slots

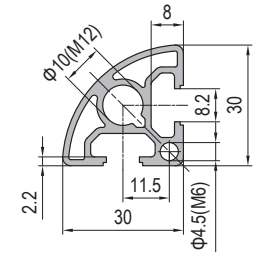

30x30 2 slots Type A

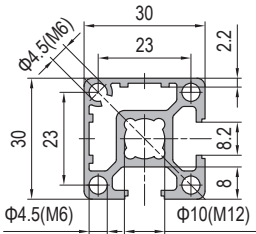

30x30 2 slots Type B

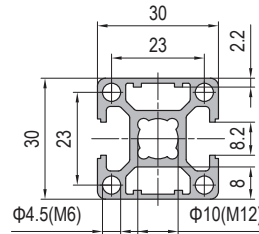

30x30 3 slots

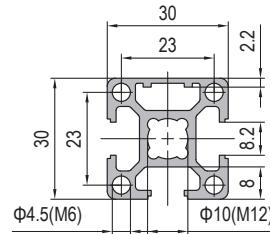

30x30 4 slots Light

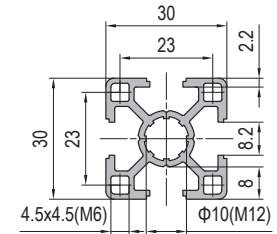

30x30 4 slots

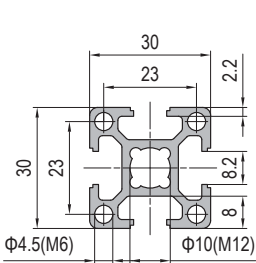

30x60 6 slots

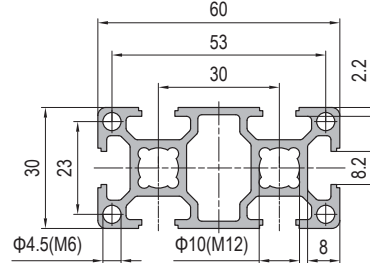

30x90 8 slots

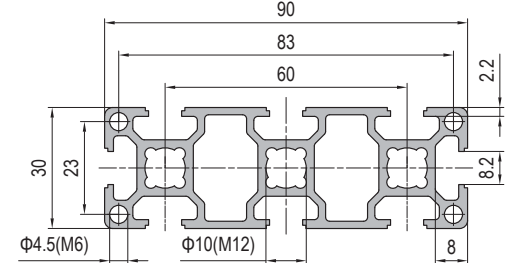

Description	Moment of Inertia $I_x(\text{cm}^4)$	Moment of Inertia $I_y(\text{cm}^4)$	Moment of Resistance $W_x(\text{cm}^3)$	Moment of Resistance $W_y(\text{cm}^3)$	Mass (kg/m)	Part No.
Strut Profile PG30 15x90 7 slots	1.4	40.4	1.9	9.0	1.5	1.11.30.015090.07
Strut Profile PG30 30x30 R45 2 slots	4.2	3.1	2.4	1.7	0.852	1.11.30.030030.R45.02 New!
Strut Profile PG30 30x30 R90 2 slots	2.0	2.0	1.5	1.5	0.8	1.11.30.030030.R90.02
Strut Profile PG30 30x30 2 slots Type A	2.9	2.9	2.0	2.0	0.9	1.11.30.030030.02A
Strut Profile PG30 30x30 2 slots Type B	2.8	3.2	1.9	2.1	0.9	1.11.30.030030.02B
Strut Profile PG30 30x30 3 slots	3.0	2.9	2.0	1.9	0.9	1.11.30.030030.03
Strut Profile PG30 30x30 4 slots Light	2.6	2.6	1.8	1.8	0.8	1.11.30.030030.04L
Strut Profile PG30 30x30 4 slots	2.9	2.9	2.0	2.0	0.9	1.11.30.030030.04
Strut Profile PG30 30x60 6 slots	5.3	19.9	3.5	6.7	1.6	1.11.30.030060.06
Strut Profile PG30 30x90 8 slots	7.7	62.0	5.1	13.8	2.2	1.11.30.030090.08



Strut Profile PG30

30x120 10 slots

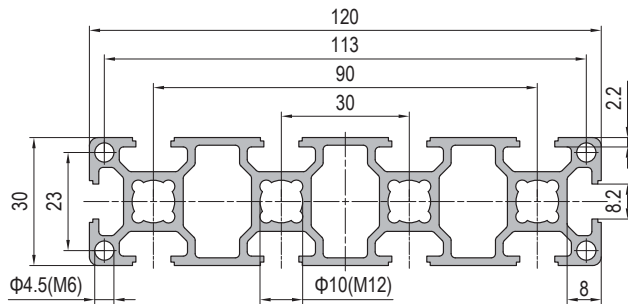

30x150 12 slots

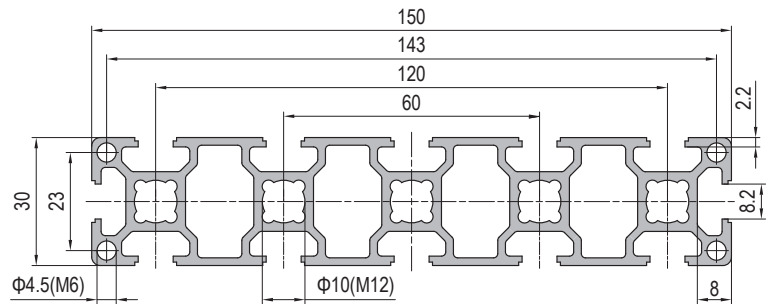

60x60 8 slots

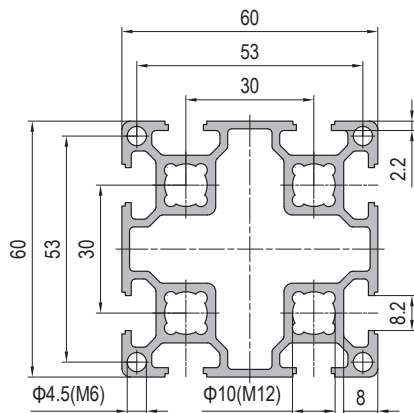

60x60 L 8 slots

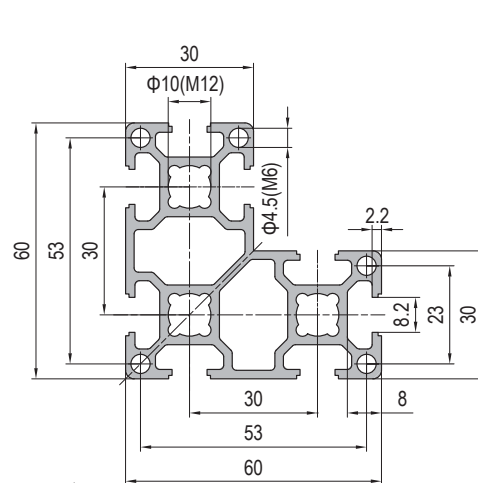

60x120 12 slots

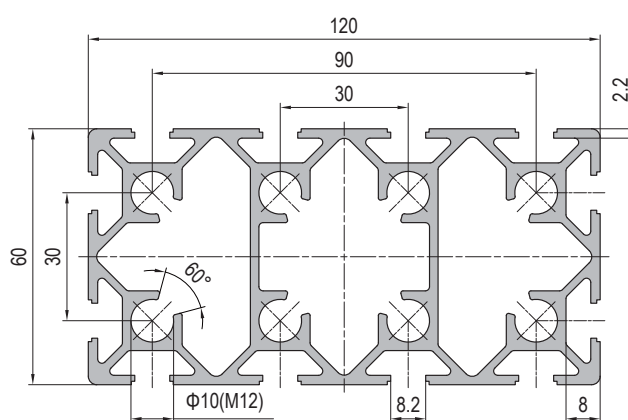

Description	Moment of Inertia $I_x(\text{cm}^4)$	Moment of Inertia $I_y(\text{cm}^4)$	Moment of Resistance $W_x(\text{cm}^3)$	Moment of Resistance $W_y(\text{cm}^3)$	Mass (kg/m)	Part No.
Strut Profile PG30 30x120 10 slots	10.1	139.9	6.7	23.3	2.9	1.11.30.030120.10
Strut Profile PG30 30x150 12 slots	12.5	264.4	8.3	35.3	3.4	1.11.30.030150.12
Strut Profile PG30 60x60 8 slots	35.3	35.3	11.8	11.8	2.5	1.11.30.060060.08
Strut Profile PG30 60x60 L 8 slots	26.4	26.4	10.4	10.4	2.3	1.11.30.060060L.08
Strut Profile PG30 60x120 12 slots	74.7	252.6	24.9	42.1	4.8	1.11.30.060120.12

Strut Profile PG40

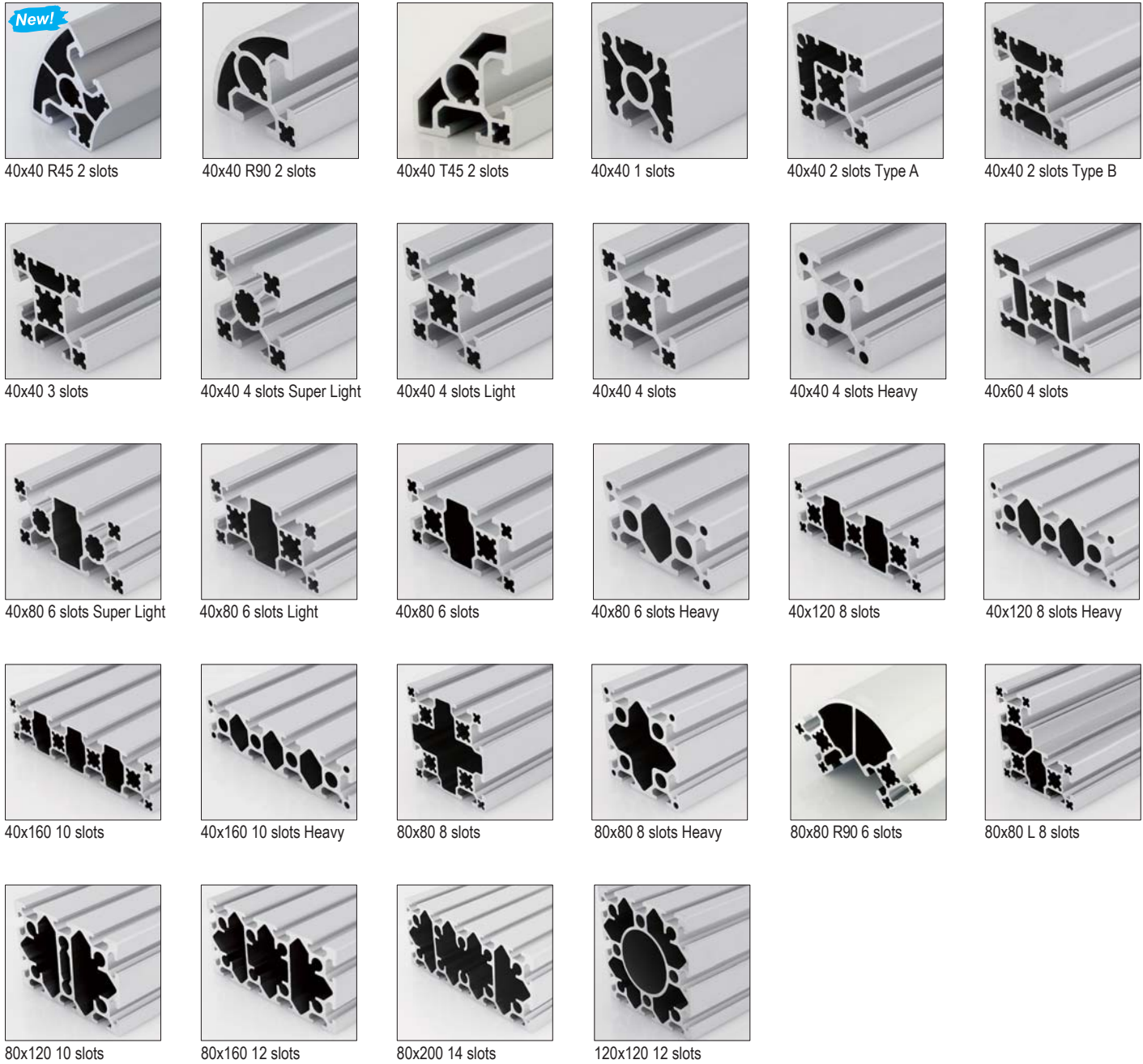

Strut profile PG40 featuring 10mm T-slot is designed for constructing medium or heavy weight assemblies, such as machine structure frame, trolley, work station, partition and display frames etc. (Profile PG40 is frequently used).

Connector selection



Strut Profile PG40

40x40 R45 2 slots

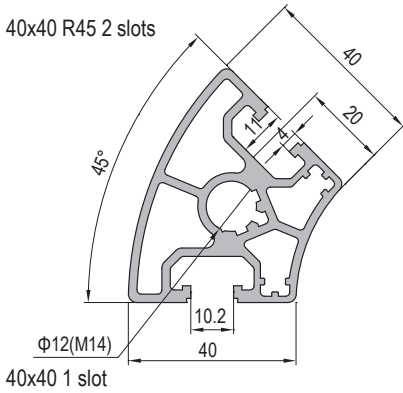

40x40 R90 2 slots

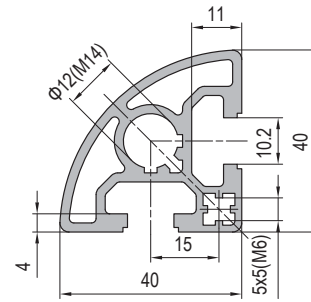

40x40 T45 2 slots

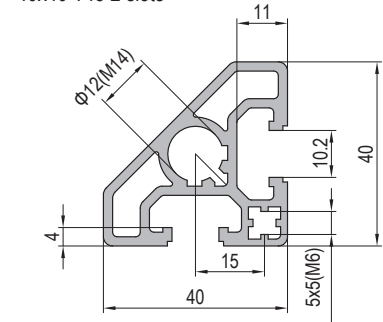

40x40 1 slot

40x40 2 slots Type A

40x40 2 slots Type B

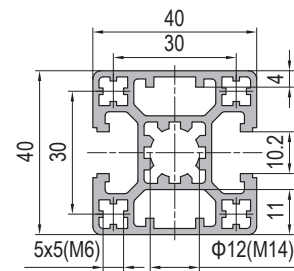
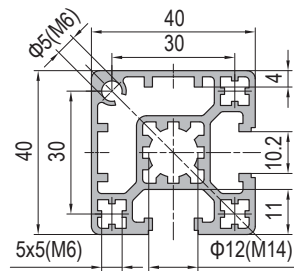
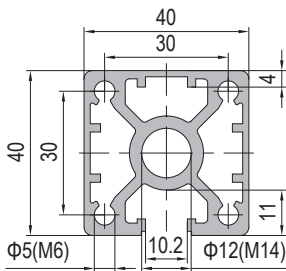

40x40 3 slots

40x40 4 slots Super Light

40x40 4 slots Light

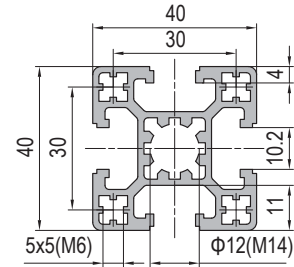
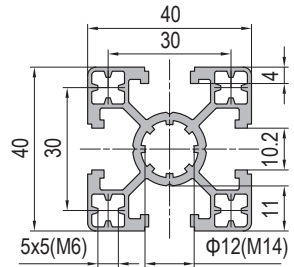
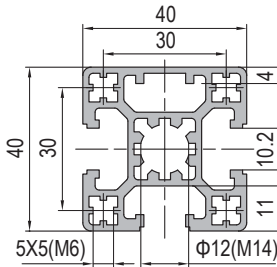

Description	Moment of Inertia $I_x(\text{cm}^4)$	Moment of Inertia $I_y(\text{cm}^4)$	Moment of Resistance $W_x(\text{cm}^3)$	Moment of Resistance $W_y(\text{cm}^3)$	Mass (kg/m)	Part No.
Strut Profile PG40 40x40 R45 slots	13.6	10.4	5.9	4.2	1.7	1.11.40.040040.R45.02 New!
Strut Profile PG40 40x40 R90 2 slots	6.5	6.5	3.7	3.7	1.3	1.11.40.040040.R90.02
Strut Profile PG40x40 T45 2 slots	6.5	6.5	3.25	3.25	1.21	1.11.40.040040.T45.02
Strut Profile PG40 40x40 1 slot	10.4	10.1	5.2	5.0	1.68	1.11.40.040040.01
Strut Profile PG40 40x40 2 slots Type A	9.6	9.6	4.5	4.5	1.5	1.11.40.040040.02A
Strut Profile PG40 40x40 2 slots Type B	9.6	8.6	4.8	4.3	1.5	1.11.40.040040.02B
Strut Profile PG40 40x40 3 slots	9.1	8.6	4.5	4.3	1.5	1.11.40.040040.03
Strut Profile PG40 40x40 4 slots Super Light	7.3	7.3	3.6	3.6	1.3	1.11.40.040040.04SL
Strut Profile PG40 40x40 4 slots Light	8.6	8.6	4.3	4.3	1.5	1.11.40.040040.04L



Strut Profile PG40

40x40 4 slots

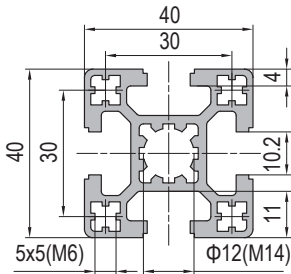

40x40 4 slots Heavy

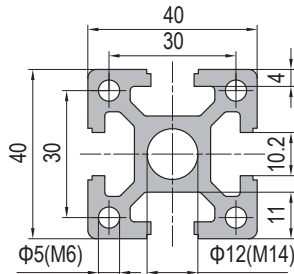

40x60 4 slots

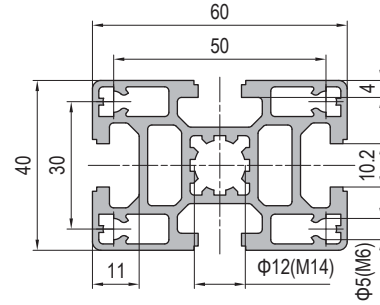

40x80 6 slots Super Light

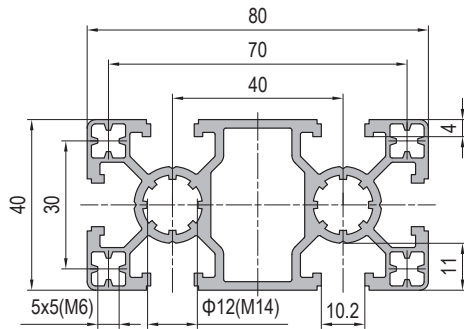

40x80 6 slots Light

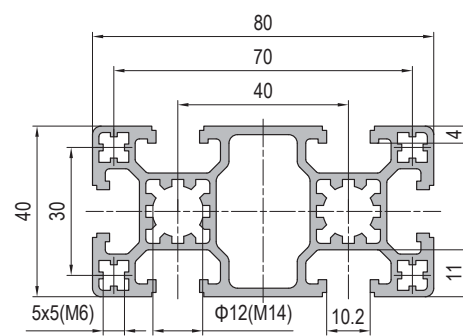

40x80 6 slots

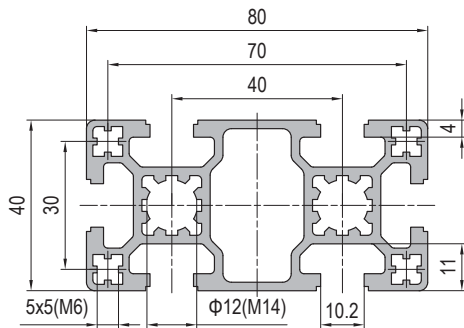

40x80 6 slots Heavy

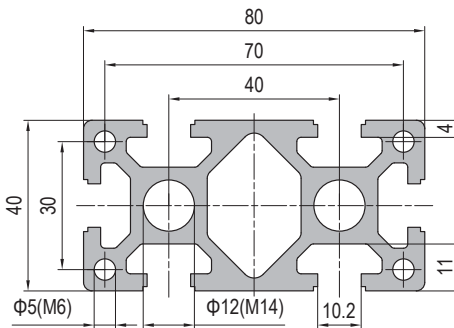

Description	Moment of Inertia $I_x(\text{cm}^4)$	Moment of Inertia $I_y(\text{cm}^4)$	Moment of Resistance $W_x(\text{cm}^3)$	Moment of Resistance $W_y(\text{cm}^3)$	Mass (kg/m)	Part No.
Strut Profile PG40 40x40 4 slots	9.1	9.1	4.6	4.6	1.6	1.11.40.040040.04
Strut Profile PG40 40x40 4 slots Heavy	11.5	11.5	5.8	5.8	2.0	1.11.40.040040.04H
Strut Profile PG40 40x60 4 slots	13.3	27.6	6.6	9.2	2.3	1.11.40.040060.04
Strut Profile PG40 40x80 6 slots Super Light	14.3	52.0	7.2	13.0	2.3	1.11.40.040080.06SL
Strut Profile PG40 40x80 6 slots Light	15.8	59.1	7.9	14.8	2.5	1.11.40.040080.06L
Strut Profile PG40 40x80 6 slots	16.6	63.2	8.3	15.8	2.7	1.11.40.040080.06
Strut Profile PG40 40x80 6 slots Heavy	22.2	80.8	11.1	20.2	3.6	1.11.40.040080.06H



Strut Profile PG40

40x120 8 slots

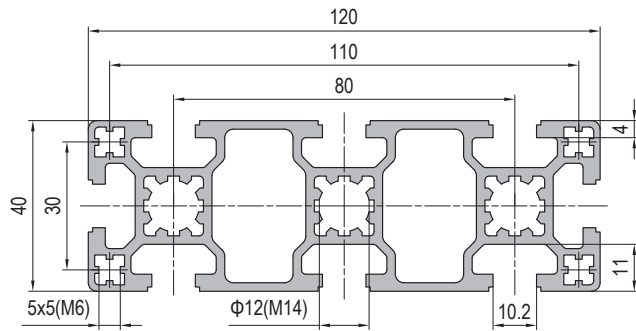

40x120 8 slots Heavy

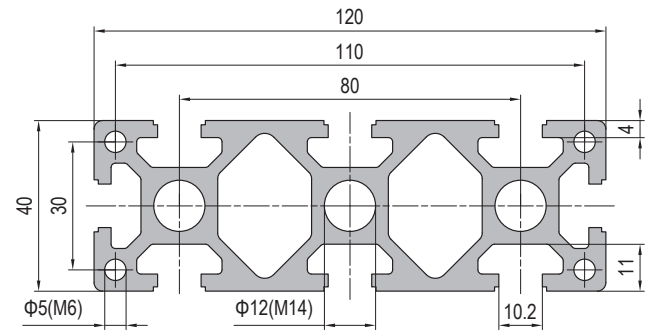

40x160 10 slots

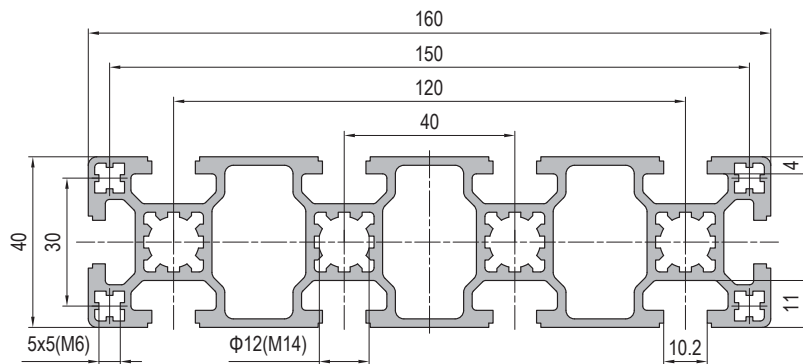

80x80 8 slots

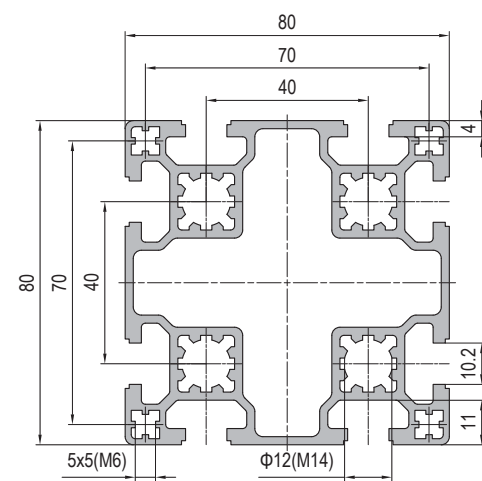

40x160 10 slots Heavy

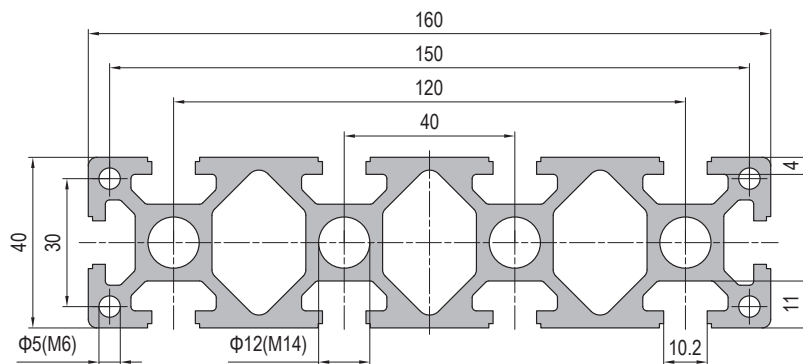

Description	Moment of Inertia	Moment of Inertia	Moment of Resistance	Moment of Resistance	Mass (kg/m)	Part No.
	$I_x(\text{cm}^4)$	$I_y(\text{cm}^4)$	$W_x(\text{cm}^3)$	$W_y(\text{cm}^3)$		
Strut Profile PG40 40x120 8 slots	24.1	194.8	12.1	32.5	3.8	1.11.40.040120.08
Strut Profile PG40 40x120 8 slots Heavy	33.0	255.3	16.5	42.6	5.2	1.11.40.040120.08H
Strut Profile PG40 40x160 10 slots	31.6	435.7	15.8	54.5	4.8	1.11.40.040160.10
Strut Profile PG40 40x160 10 slots Heavy	43.7	582.2	21.8	72.8	6.8	1.11.40.040160.10H
Strut Profile PG40 80x80 8 slots	109.9	109.9	27.5	27.5	4.2	1.11.40.080080.08

Strut Profile PG40

80x80 8 slots Heavy

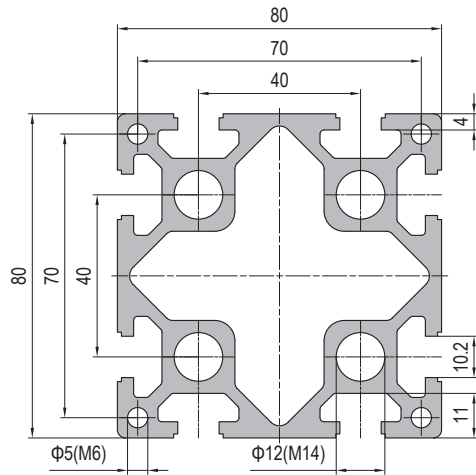

80x80 R90 6 slots

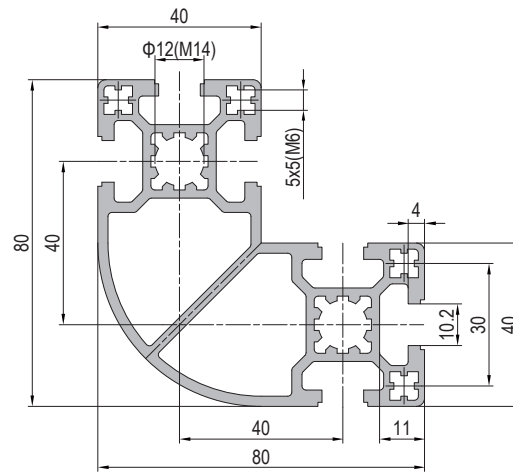

80x80 L 8 slots

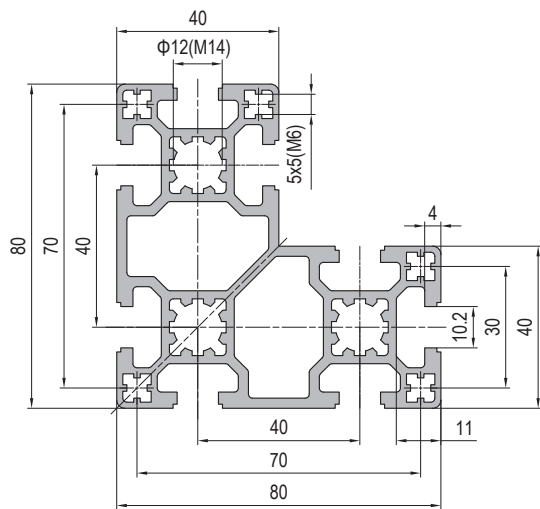

80x120 10 slots

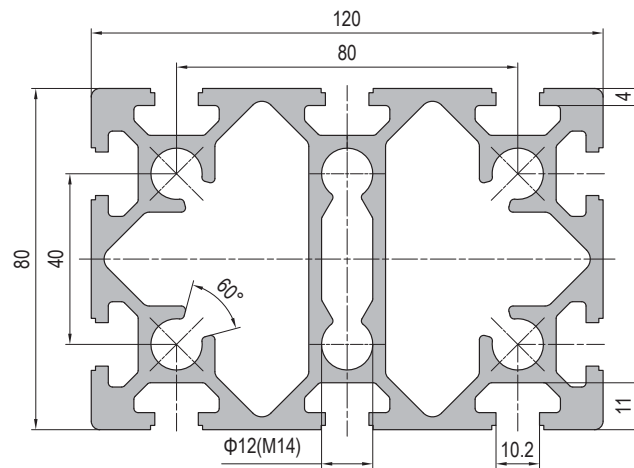

Description	Moment of Inertia $I_x(\text{cm}^4)$	Moment of Inertia $I_y(\text{cm}^4)$	Moment of Resistance $W_x(\text{cm}^3)$	Moment of Resistance $W_y(\text{cm}^3)$	Mass (kg/m)	Part No.
Strut Profile PG40 80x80 8 slots Heavy	148.2	148.2	37.1	37.1	5.7	1.11.40.080080.08H
Strut Profile PG40 80x80 R90 6 slots	73	73	20	20	3.4	1.11.40.080080.R90.06
Strut Profile PG40 80x80 L 8 slots	83.9	83.9	24.7	24.7	4.0	1.11.40.080080L.08
Strut Profile PG40 80x120 10 slots	222.1	449.2	55.5	74.8	8.3	1.11.40.080120.10

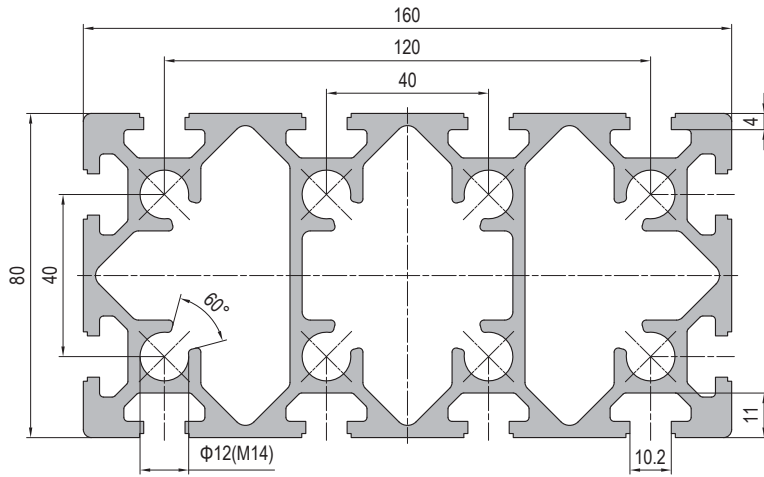
Strut Profile PG40
 80x160 12 slots

120x120 12 slots

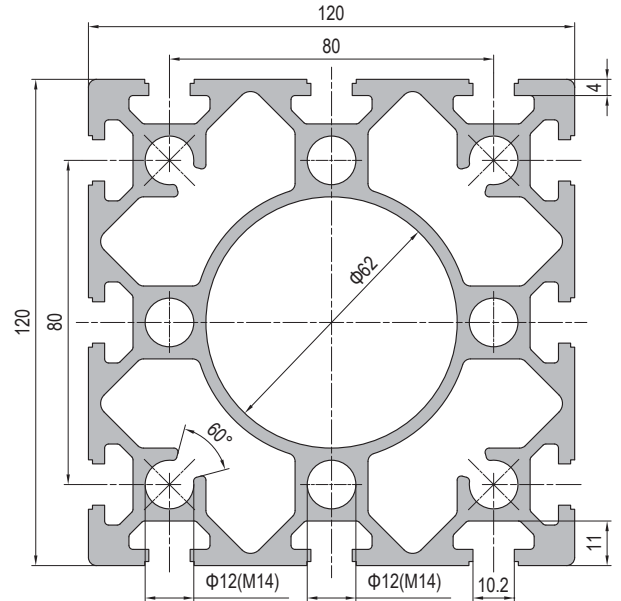

80x200 14 slots

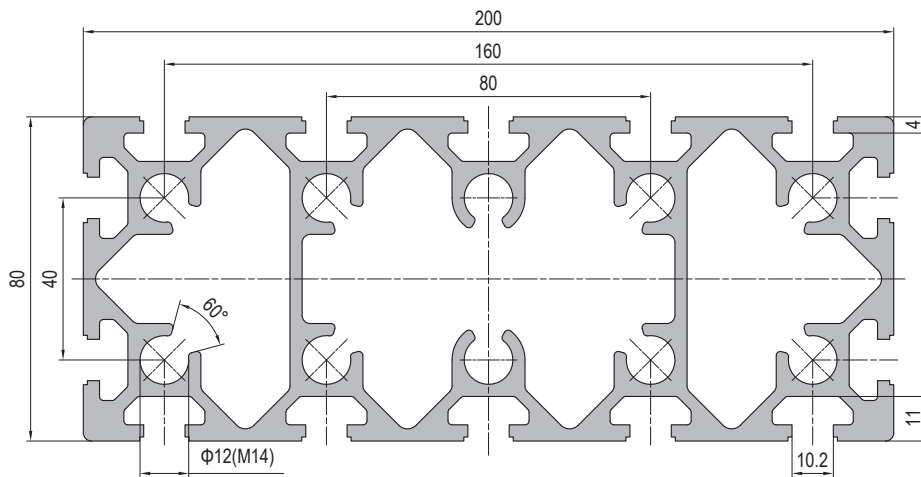

Description	Moment of Inertia $I_x(\text{cm}^4)$	Moment of Inertia $I_y(\text{cm}^4)$	Moment of Resistance $W_x(\text{cm}^3)$	Moment of Resistance $W_y(\text{cm}^3)$	Mass (kg/m)	Part No.
Strut Profile PG40 80x160 12 slots	287.5	975.5	71.9	121.9	10.4	1.11.40.080160.12
Strut Profile PG40 80x200 14 slots	353.1	1789.8	88.3	179.0	12.3	1.11.40.080200.14
Strut Profile PG40 120x120 12 slots	659.1	659.1	109.9	109.9	11.5	1.11.40.120120.12

Strut Profile PG45



45x45 R45 2 slots



45x45 R90 2 slots



45x45 2 slots Type A



45x45 2 slots Type B



45x45 3 slots



45x45 4 slots Light



45x45 4 slots



45x45 4 slots Heavy



45x60 4 slots



45x90 6 slots Light

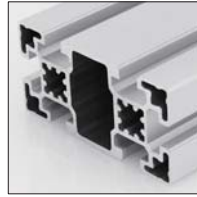

45x90 6 slots



45x90 6 slots Heavy



45x180 10 slots



90x90 8 slots



90x90 8 slots Heavy



90x90 L 8 slots



90x180 12 slots

Strut Profile PG45 featuring 10mm T-slot is designed for constructing heavy weight assemblies such as machine structure frame and workshop partition etc.

Connector selection



Anchor Connectorast P. 3-03



Die Cast Bracket P. 3-10



Angle Profile Bracket P. 3-15



Inner Bracket P. 3-31



Linear Bar Connector P. 3-32



Screw Connector P. 3-42



Strut Profile PG45

45x45 R45 2 slots

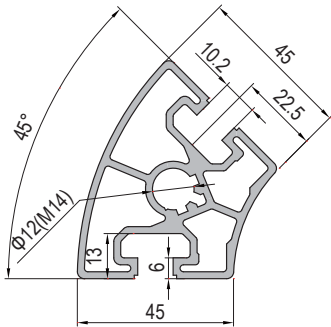

45x45 R90 2 slots

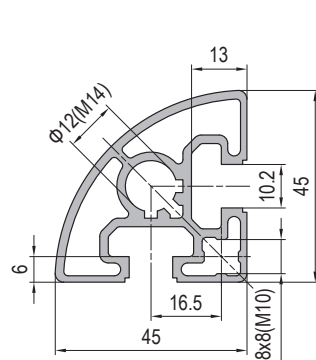

45x45 2 slots Type A

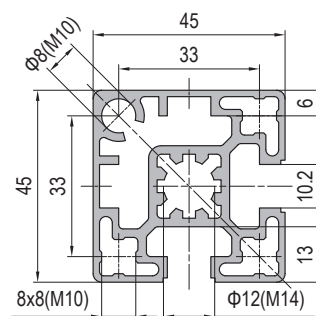

45x45 2 slots Type B

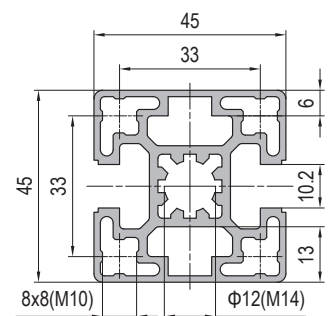

45x45 3 slots

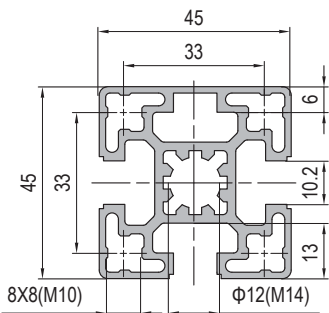

45x45 4 slots Light

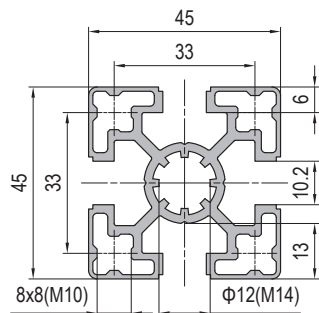

45x45 4 slots

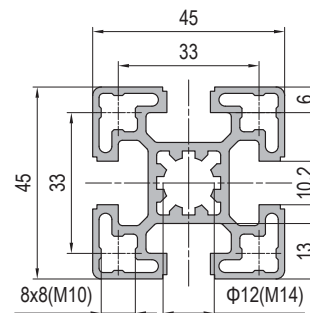

45x45 4 slots Heavy

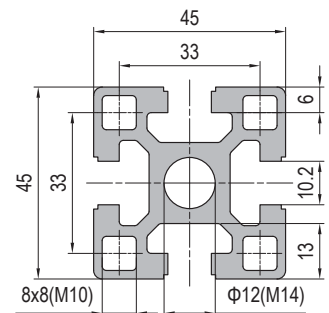

Description	Moment of Inertia $I_x(\text{cm}^4)$	Moment of Inertia $I_y(\text{cm}^4)$	Moment of Resistance $W_x(\text{cm}^3)$	Moment of Resistance $W_y(\text{cm}^3)$	Mass (kg/m)	Part No.
Strut Profile PG45 45x45 R45 2 slots	20.1	15.3	7.9	5.5	2.0	1.11.45.045045.R45.02 New!
Strut Profile PG45 45x45 R90 2 slots	8.4	8.4	4.3	4.3	1.5	1.11.45.045045.R90.02
Strut Profile PG45 45x45 2 slots Type A	12.9	12.9	5.7	5.7	1.9	1.11.45.045045.02A
Strut Profile PG45 45x45 2 slots Type B	13.7	12.1	6.1	5.4	1.9	1.11.45.045045.02B
Strut Profile PG45 45x45 3 slots	12.9	12.1	5.7	5.4	1.8	1.11.45.045045.03
Strut Profile PG45 45x45 4 slots Light	10.5	10.5	4.7	4.7	1.6	1.11.45.045045.04L
Strut Profile PG45 45x45 4 slots	12.1	12.1	5.4	5.4	1.8	1.11.45.045045.04
Strut Profile PG45 45x45 4 slots Heavy	16.5	16.5	7.4	7.4	2.4	1.11.45.045045.04H



Strut Profile PG45

45x60 4 slots

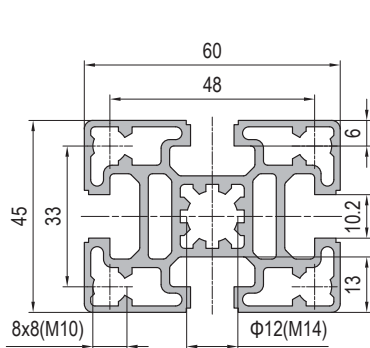

45x90 6 slots Light

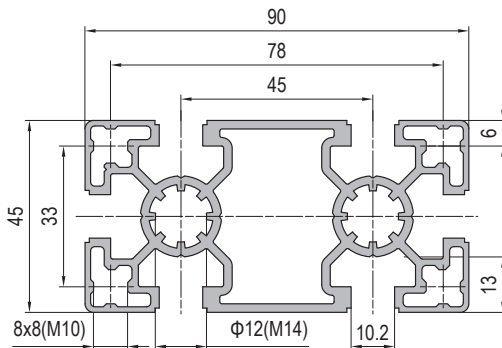

45x90 6 slots

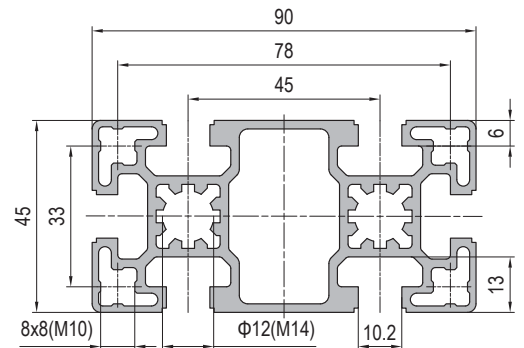

45x90 6 slots Heavy

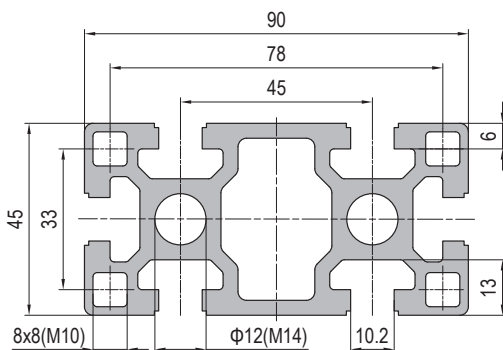

45x180 10 slots

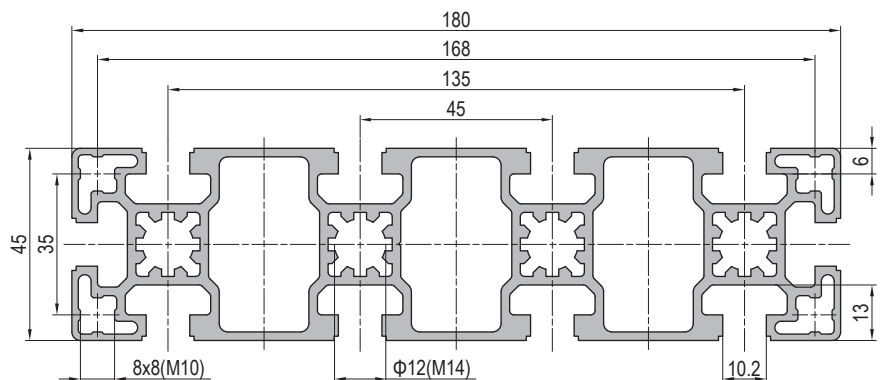

Description	Moment of Inertia	Moment of Inertia	Moment of Resistance	Moment of Resistance	Mass (kg/m)	Part No.
	$I_x(\text{cm}^4)$	$I_y(\text{cm}^4)$	$W_x(\text{cm}^3)$	$W_y(\text{cm}^3)$		
Strut Profile PG45 45x60 4 slots	16.2	27.8	7.2	9.3	2.4	1.11.45.045060.04
Strut Profile PG45 45x90 6 slots Light	21.6	80.0	9.6	17.7	2.85	1.11.45.045090.06L New!
Strut Profile PG45 45x90 6 slots	24.2	89.3	10.8	19.9	3.2	1.11.45.045090.06
Strut Profile PG45 45x90 6 slots Heavy	32.5	122.2	14.5	27.2	4.4	1.11.45.045090.06H
Strut Profile PG45 45x180 10 slots	48.4	640.6	21.5	71.2	5.8	1.11.45.045180.10

Strut Profile PG45

90x90 8 slots

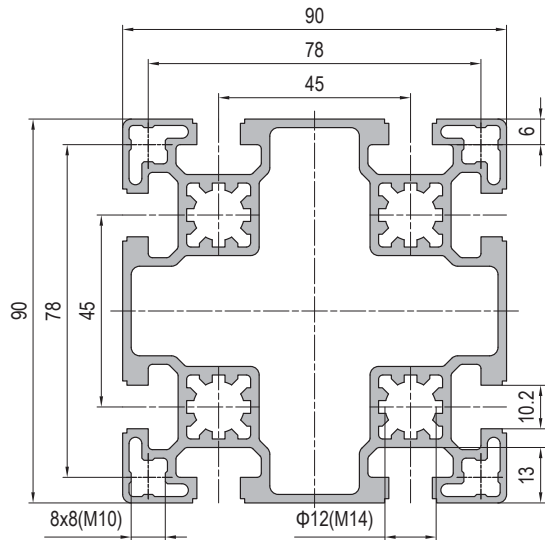

90x90 8 slots Heavy

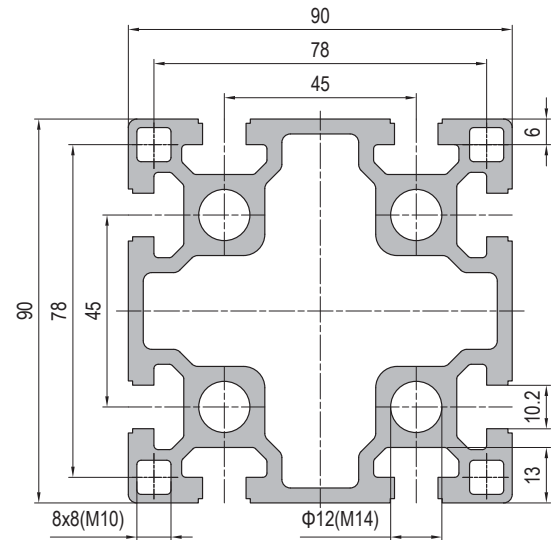

90x90 L 8 slots

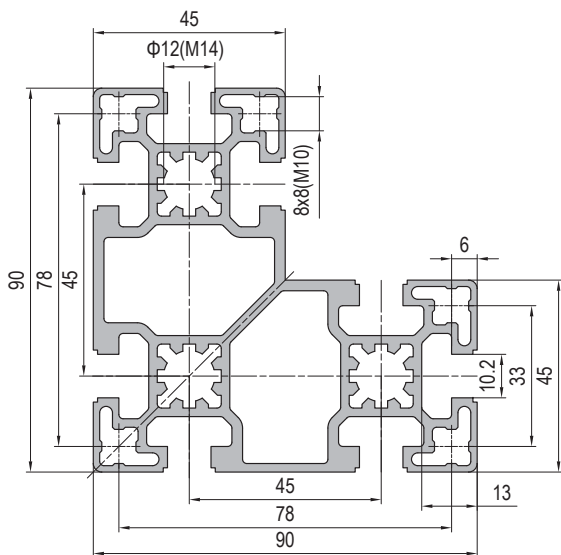

90x180 12 slots

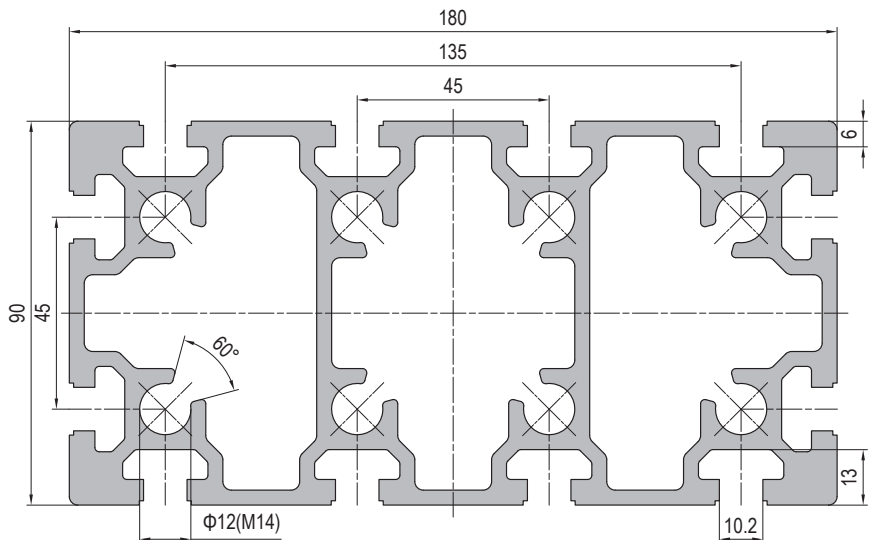

Description	Moment of Inertia $I_x(\text{cm}^4)$	Moment of Inertia $I_y(\text{cm}^4)$	Moment of Resistance $W_x(\text{cm}^3)$	Moment of Resistance $W_y(\text{cm}^3)$	Mass (kg/m)	Part No.
Strut Profile PG45 90x90 8 slots	163.2	163.2	36.3	36.3	5.0	1.11.45.090090.08
Strut Profile PG45 90x90 8 slots Heavy	222.9	222.9	49.6	49.6	6.8	1.11.45.090090.08H
Strut Profile PG45 90x90 L 8 slots	121.5	121.5	32	32	4.6	1.11.45.090090L.08
Strut Profile PG45 90x180 12 slots	454.9	1585.7	101.1	176.2	12.7	1.11.45.090180.12

Strut Profile PG50



Strut profile PG50 featuring 10mm T-slot is designed for constructing heavy weight assemblies.

50x50 4 slots Light

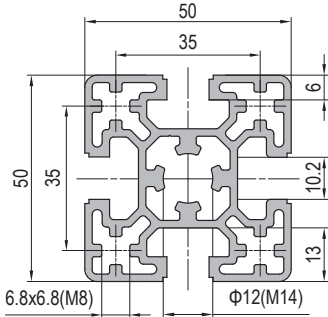

50x50 4 slots

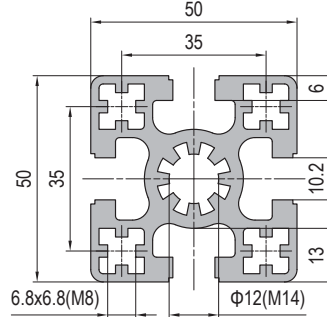

50x100 6 slots Light

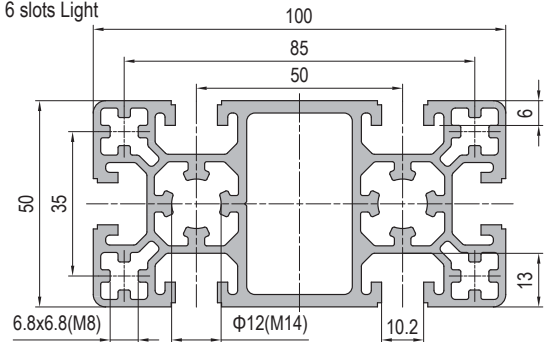

50x100 6 slots

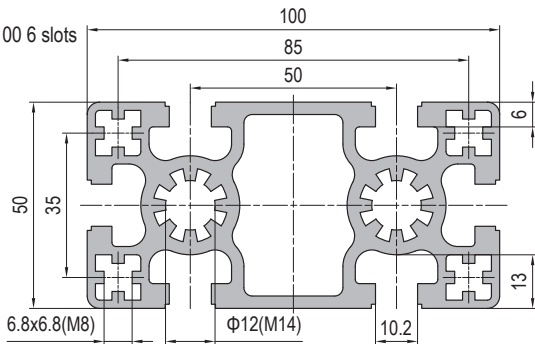

100x100 8 slots

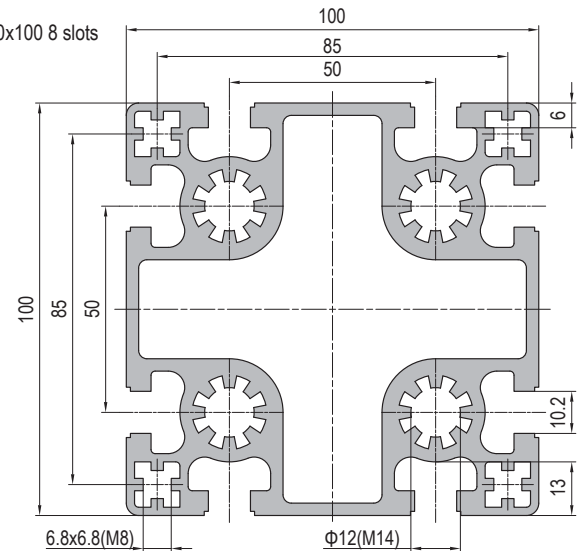

Connector selection



Die Cast Bracket P. 3-11



Angle Profile Bracket P. 3-15



Screw Connector P. 3-42

Description	Moment of Inertia	Moment of Inertia	Moment of Resistance	Moment of Resistance	Mass (kg/m)	Part No.
Strut Profile PG50 50x50 4 slots Light	20.19	20.19	8.16	8.16	2.35	1.11.50.050050.04L
Strut Profile PG50 50x50 4 slots	25.0	25.0	10.0	10.0	3.0	1.11.50.050050.04
Strut Profile PG50 50x100 6 slots Light	41.3	156.7	16.5	31.3	4.2	1.11.50.050100.06L
Strut Profile PG50 50x100 6 slots	46.2	184.4	18.5	36.9	5.0	1.11.50.050100.06
Strut Profile PG50 100x100 8 slots	331.1	331.1	66.2	66.2	8.5	1.11.50.100100.08



Strut Profile PG60



60x60 4 slots

Strut profile PG60 featuring 10mm T-slot is designed for constructing heavy weight assemblies.

60x60 4 slots

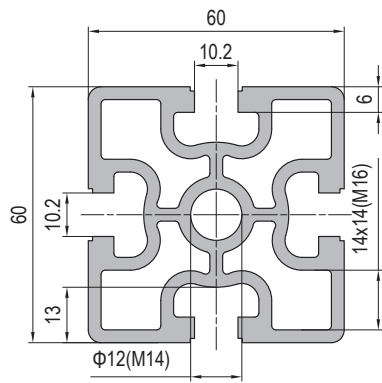

Connector selection



Angle Profile Bracket P. 3-15



Screw Connector P. 3-42

Description	Moment of Inertia $I_x(\text{cm}^4)$	Moment of Inertia $I_y(\text{cm}^4)$	Moment of Resistance $W_x(\text{cm}^3)$	Moment of Resistance $W_y(\text{cm}^3)$	Mass (kg/m)	Part No.
Strut Profile PG60 60x60 4 slots	47.7	47.7	15.9	15.9	3.8	1.11.60.060060.04



Angle Profile

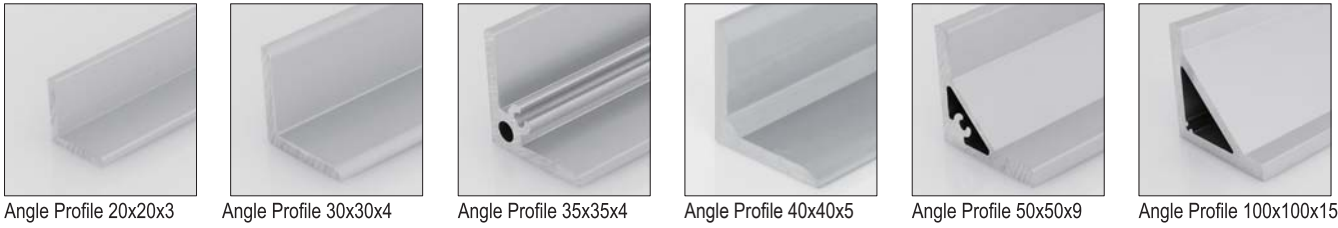

Angle profile is mainly used for producing angle bracket which has a wide range of applications with its good flexibility. The surface treatment of the finished product can be natural anodized, black anodized, electrochromic paint etc.

Angle Profile 20x20x3

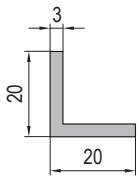

Angle Profile 30x30x4

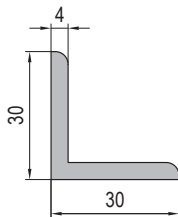

Angle Profile 35x35x4

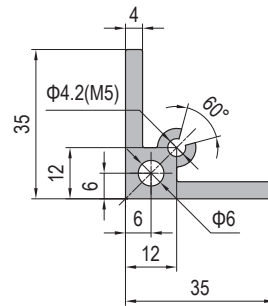

Angle Profile 40x40x5

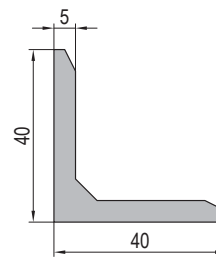

Angle Profile 50x50x9

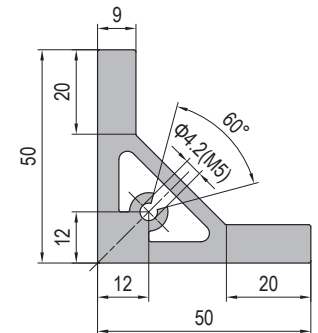

Angle Profile 100x100x15

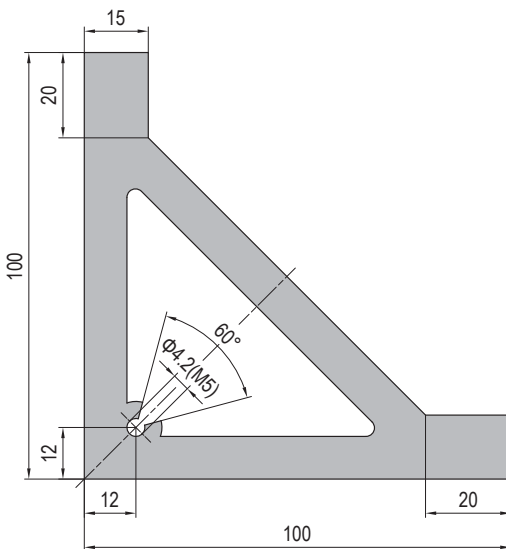

Description	Mass (kg/m)	Part No.
Angle Profile 20x20x3	0.3	1.31.2020.03
Angle Profile 30x30x4	0.6	1.31.3030.04
Angle Profile 35x35x4	0.9	1.31.3535.04
Angle Profile 40x40x5	1	1.31.4040.05
Angle Profile 50x50x9	2.3	1.31.5050.09
Angle Profile 100x100x15	8.5	1.31.100100.15

Note: The maximum delivery length of angle profile 100x100x15 is 4000mm, the others are all 5800mm.



Conduit Profile

Conduit Profile-40x40

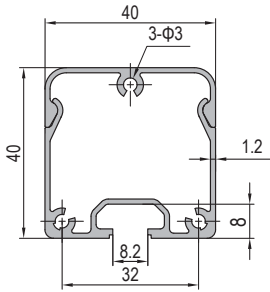

Conduit Profile-40x80

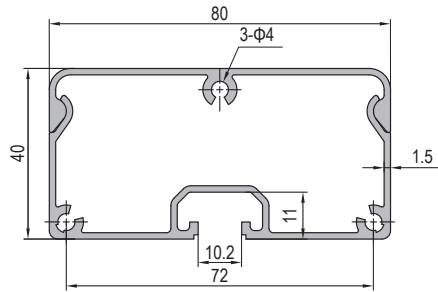

Conduit Profile-60x120

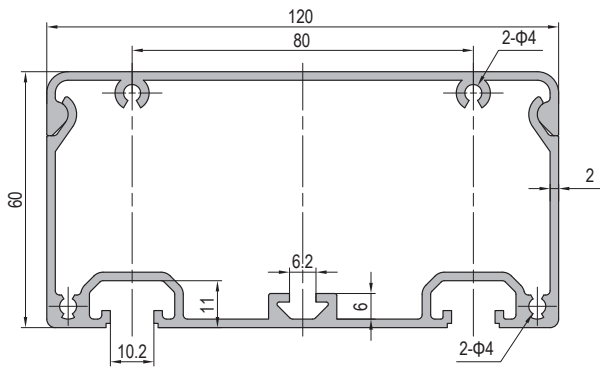

Conduit Profile-80x80

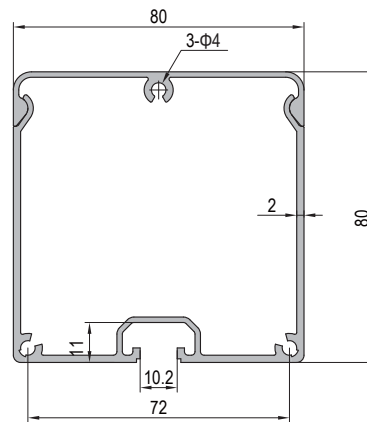

Conduit Profile-80x160

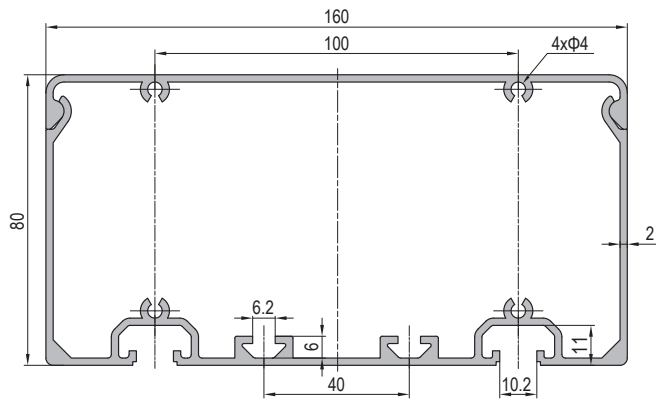

Conduit Profile-80x200

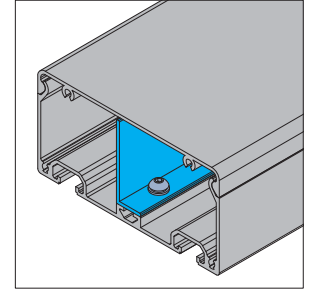
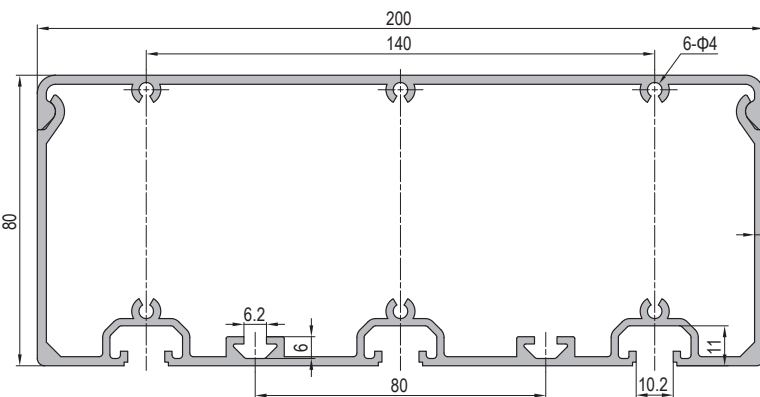

Partition Profile-16x48

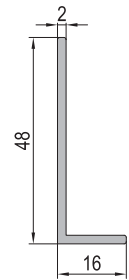

Description	Mass (kg/m)	Part No.
Conduit Profile 40x40	0.82	1.41.40.040040
Conduit Profile 40x80	1.41	1.41.40.040080
Conduit Profile 60x120	2.80	1.41.40.060120
Conduit Profile 80x80	1.94	1.41.40.080080
Conduit Profile 80x160	3.64	1.41.40.080160
Conduit Profile 80x200	4.89	1.41.40.080200
Partition Profile 16x48	0.35	1.31.1648.02

Note:

1. the partition profile is used for partition and arrangement of cables inside of big conduit profiles to realize the reasonable design.

2. the partition profile is used for partition and arrangement of cables





2.11-2.51

Pre-set Nut

Square Nut

T Nut

Subsequent Nut

Anti-torsion Subsequent Nut

T Bolt

Hole Reducer Bolt

2

Fastening Elements



P. 2-02



P. 2-03



P. 2-04



P. 2-05



P. 2-06



P. 2-07



P. 2-08



Fastening Elements

Pre-set Nut

Pre-set Nut can be only put into T slot from profile end, with low assembly efficiency, but with good connection and stability. The sleeve is to avoid any sliding when using the pre-set nut for assembly and can be fixed at any required position, especially in vertical position.

Material: Pre-set Nut-nickel plated steel Pre-set Nut Sleeve-EVA

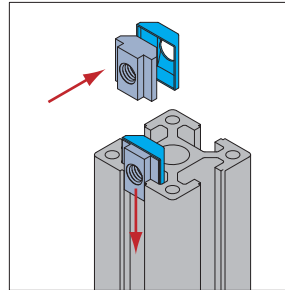

Reliability	★★★★★
Efficiency	★★★
Economical	★★★

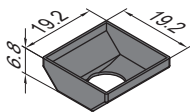
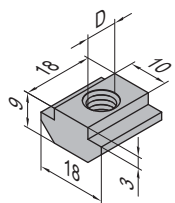
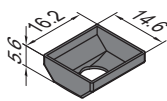
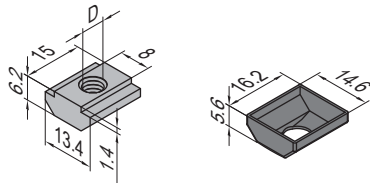
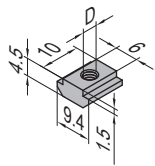

Description	D	Mass (g/pcs)	Part No.
Pre-set Nut-6-M4	M4	3	2.11.06.M4
Pre-set Nut-6-M5	M5		2.11.06.M5

Description	D	Mass (g/pcs)	Part No.
Pre-set Nut-8-M4	M4	8	2.11.08.M4
Pre-set Nut-8-M5	M5	8	2.11.08.M5
Pre-set Nut-8-M6	M6	7	2.11.08.M6
Pre-set Nut Sleeve-8		0.3	2.11.08.01

Description	D	Mass (g/pcs)	Part No.
Pre-set Nut-10-M4	M4	16	2.11.10.M4
Pre-set Nut-10-M5	M5	16	2.11.10.M5
Pre-set Nut-10-M6	M6	15	2.11.10.M6
Pre-set Nut-10-M8	M8	14	2.11.10.M8
Pre-set Nut Sleeve-10		0.4	2.11.10.01



Fastening Elements

Square Nut

The clip is to avoid any sliding when using the square nut for assembly and can be fixed at any required position, especially at vertical position.

Material: zinc plated steel

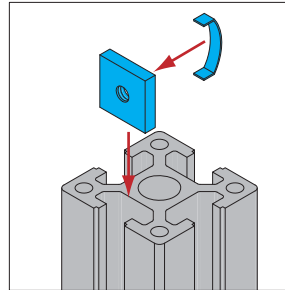

Reliability	★ ★ ★
Efficiency	★ ★ ★
Economical	★ ★ ★ ★ ★

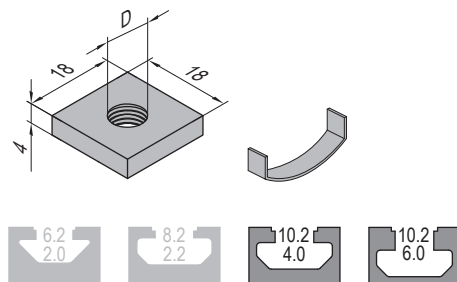
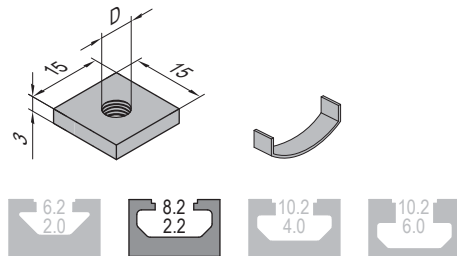

Description	D	Mass (g/pcs)	Part No.
Square Nut-8-M4	M4	5	2.12.08.M4
Square Nut-8-M5	M5		2.12.08.M5
Square Nut-8-M6	M6		2.12.08.M6
Square Nut Clip-8			0.4

Description	D	Mass (g/pcs)	Part No.
Square Nut-10-M4	M4	10	2.12.10.M4
Square Nut-10-M5	M5	10	2.12.10.M5
Square Nut-10-M6	M6	9	2.12.10.M6
Square Nut-10-M8	M8	8	2.12.10.M8
Square Nut Clip-10		0.5	2.12.10.01



Fastening Elements

T Nut

T Nut can be inserted directly at the assembly point, which makes the assembly very efficient, however the connection strength and stability is not as good as pre-set nut.

Material: nickel plated steel

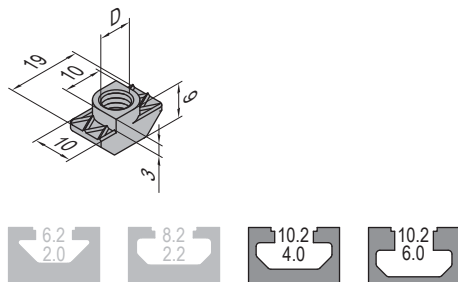
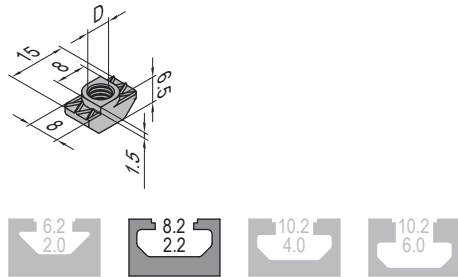
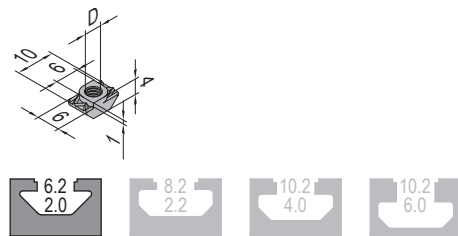
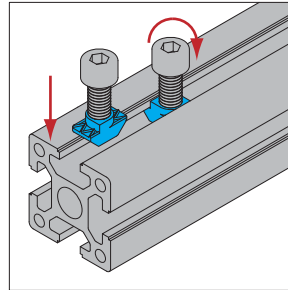

Description	D	Mass (g/pcs)	Part No.
T Nut-6-M4	M4	2	2.21.06.M4
T Nut-6-M5	M5		2.21.06.M5

Description	D	Mass (g/pcs)	Part No.
T Nut-8-M4	M4	4	2.21.08.M4
T Nut-8-M5	M5	4	2.21.08.M5
T Nut-8-M6	M6	3	2.21.08.M6

Description	D	Mass (g/pcs)	Part No.
T Nut-10-M4	M4	8	2.21.10.M4
T Nut-10-M5	M5	8	2.21.10.M5
T Nut-10-M6	M6	7	2.21.10.M6
T Nut-10-M8	M8	6	2.21.10.M8



Fastening Elements

Subsequent Nut

Subsequent Nut with a spring leaf can be inserted directly at the assembly point. The spring assists with assembly and positioning. The connecting strength and stability is same as t nut.

Material: zinc plated steel



Reliability 强度:	★★★★
Efficiency 安装效率:	★★★★
Economical 经济:	★★★

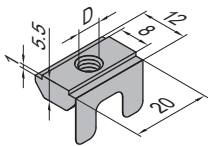
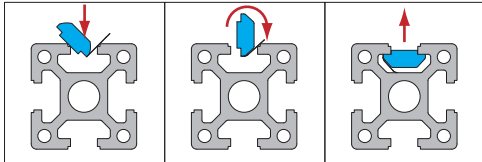

Description	D	Mass (g/pcs)	Part No.
Subsequent Nut -8-M4	M4	8	2.31.08.M4
Subsequent Nut -8-M5	M5		2.31.08.M5
Subsequent Nut -8-M6	M6	7	2.31.08.M6
Subsequent Nut -8-M8	M8		2.31.08.M8

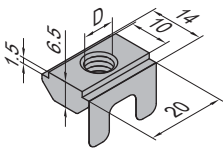

Description	D	Mass (g/pcs)	Part No.
Subsequent Nut -10-M4	M4	10	2.31.10.M4
Subsequent Nut -10-M5	M5		2.31.10.M5
Subsequent Nut -10-M6	M6	9	2.31.10.M6
Subsequent Nut -10-M8	M8		2.31.10.M8



Fastening Elements

Anti-torsion Subsequent Nut

Prevent profiles with screw connectors from torsion.

Material: nickel plated steel

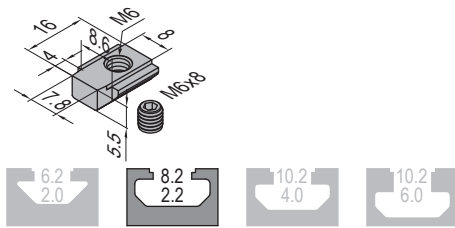
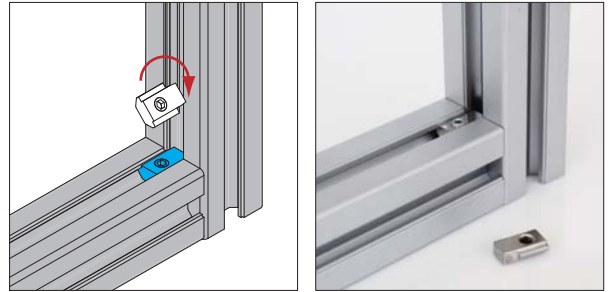

Description	Mass (g/pcs)	Part No.
Anti-torsion Subsequent Nut-8 (with top thread)	10	2.32.08.M6

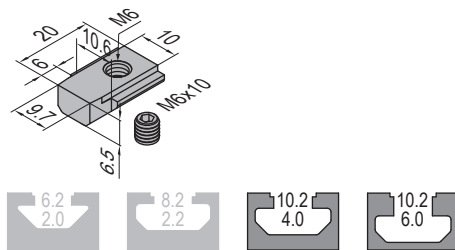

Description	Mass (g/pcs)	Part No.
Anti-torsion Subsequent Nut-10 (with top thread)	15	2.32.10.M6

Fastening Elements

T Bolt

Similar to T nut, T bolt can be inserted directly at assembly point, with high assembly efficiency. The connection strength and stability are same as T nut.

Material: nickel plated steel

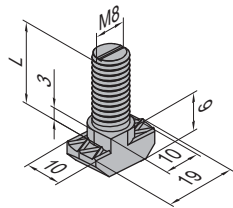
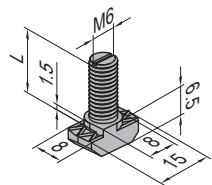
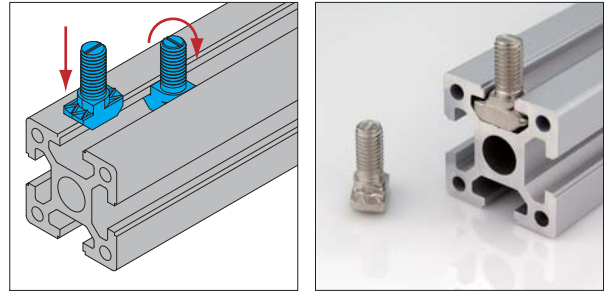

Description	L (mm)	Mass (g/pcs)	Part No.
T Bolt-8-16	16	7	2.41.08.16
T Bolt-8-20	20	8	2.41.08.20
T Bolt-8-25	25	9	2.41.08.25

Description	L (mm)	Mass (g/pcs)	Part No.
T Bolt-10-20	20	13	2.41.10.20
T Bolt-10-25	25	15	2.41.10.25
T Bolt-10-30	30	17	2.41.10.30
T Bolt-10-35	35	19	2.41.10.35 New!



Fastening Elements

Hole Reducer Bolt



To reduce the hole diameter of the profile and improve the thread connection strength.

Material: nickel plated steel

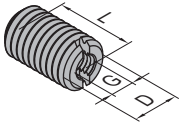

Description	D	G	L (mm)	Mass (g/pcs)	Part No.
Hole Reducer Bolt-M10/M6	M10	M6	15	8	2.51.10.06
Hole Reducer Bolt-M12/M6	M12	M6	20	11	2.51.12.06
Hole Reducer Bolt-M14/M8	M14	M8	20	14	2.51.14.08
Hole Reducer Bolt-M14/M10	M14	M10	20	8	2.51.14.10
Hole Reducer Bolt-M16/M8	M16	M8	20	19	2.51.16.08



Hole Reducer Bolt M10/M6
PG45 with square corner hole-8x8(M10)



Hole Reducer Bolt M12/M6
PG30 with core hole-Φ10(M12)



Hole Reducer Bolt M14/M8
PG40/PG45/PG50/PG60 with core hole-Φ12(M14)



Hole Reducer Bolt M16/M8
PG60 with square corner hole-14x14(M16)



3.11-3.92

- Anchor Connector
- Die Cast Bracket
- Angle Profile Bracket
- Inner Bracket
- Linear Bar Connector
- Joining Plate
- Butt Connector
- End Connector
- Screw Connector
- Cubic Connector

3

Connecting Elements



P. 3-03



P. 3-07



P. 3-12



P. 3-31



P. 3-32



P. 3-34



P. 3-40



P. 3-41



P. 3-42







P. 3-43

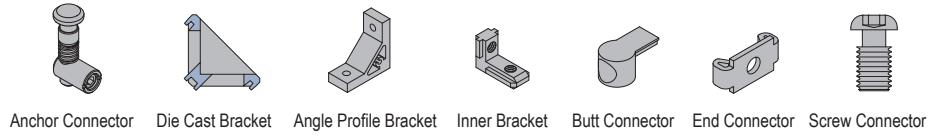

Selection Reference

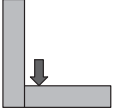
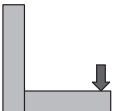
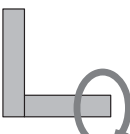
 Recommended
  Suitable
  Unsuitable

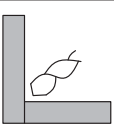

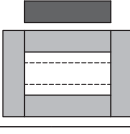
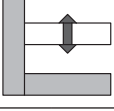
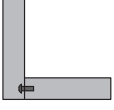
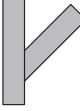
	Anchor Connector	Die Cast Bracket	Angle Profile Bracket	Inner Bracket	Butt Connector	End Connector	Screw Connector
 High feed force							
 High moment							
 High torsional moment							 
 Minimal finishing work							
 Minimal assembly							
 Low parts costs							
 Subsequent mounting in closed frame							
 Adjustment possible							
 Internal connection (concealable)							
 Angle connection							

Connecting Elements

Anchor Connector



Material: zinc plated steel



Universal

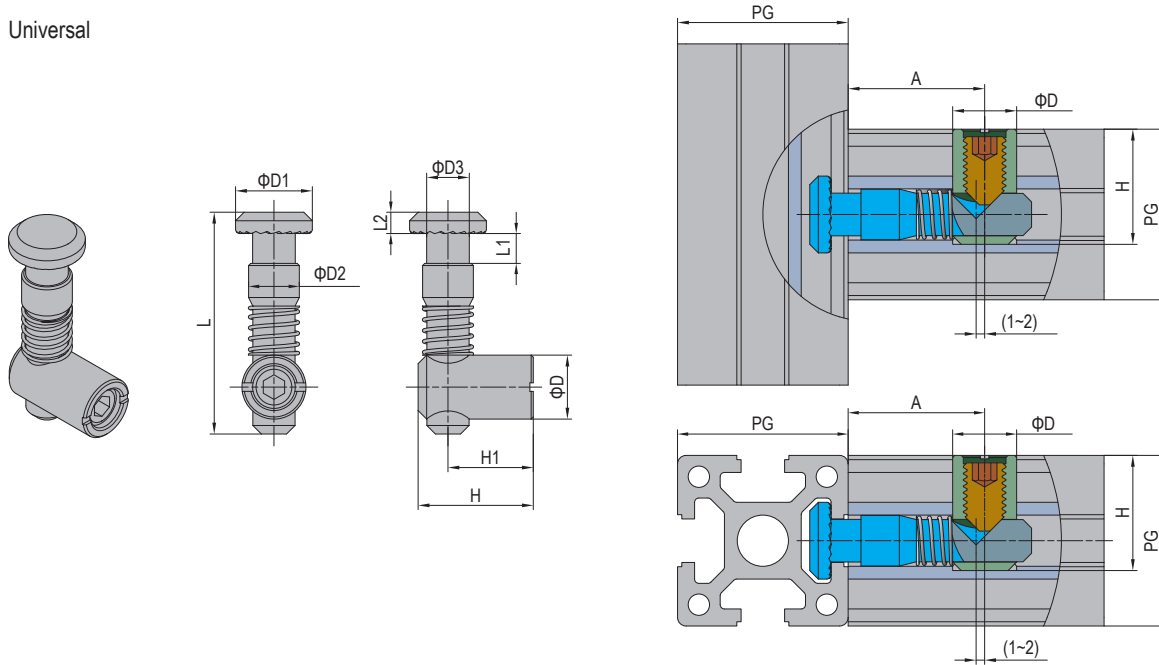

Description	A	D	H	H1	L1	L2	D1	D2	D3	L	Mass	Part No.
PG30-Universal	30	12	21	15	7	4	14	9.9	8	45	38	3.11.30.01
PG40-Universal	32	15	27	20	7	5	18	11.9	10	52	58	3.11.40.01
PG45-Universal	30	15	29.5	22.5	7	5	18	11.9	10	52	60	3.11.45.01

Connecting Elements

Anchor Connector



Material: zinc plated steel



Standard (Model P)

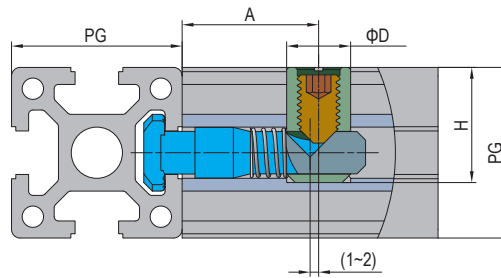
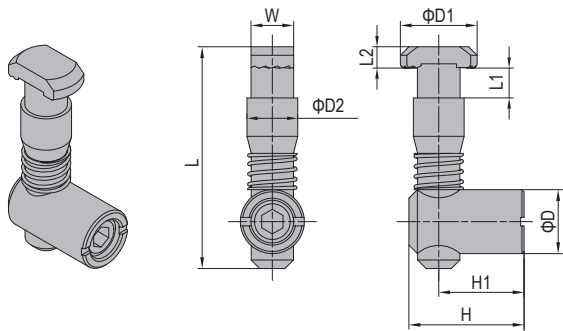

Description	A	D	H	H1	L1	L2	D1	D2	W	L	Mass	Part No.
PG30-Standard (Model P)	30	12	21	15	7	4	14	9.9	8	45	38	3.11.30.02
PG40-Standard (Model P)	32	15	27	20	7	5	18	11.9	10	52	58	3.11.40.02
PG45-Standard (Model P)	30	15	29.5	22.5	7	5	18	11.9	10	52	60	3.11.45.02

Standard (Model C)

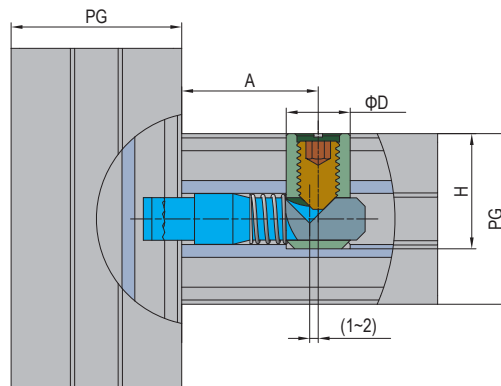
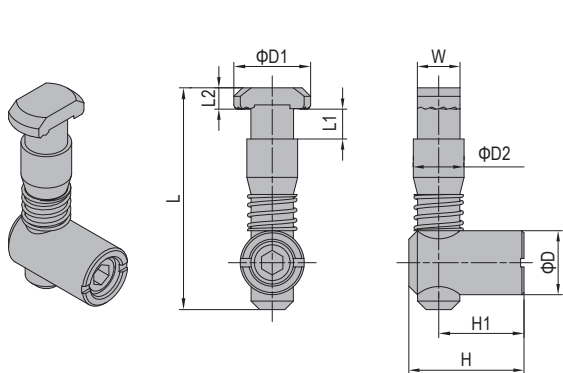

Description	A	D	H	H1	L1	L2	D1	D2	W	L	Mass	Part No.
PG30-Standard (Model C)	30	12	21	15	7	4	14	9.9	8	45	38	3.11.30.03
PG40-Standard (Model C)	32	15	27	20	7	5	18	11.9	10	52	58	3.11.40.03
PG45-Standard (Model C)	30	15	29.5	22.5	7	5	18	11.9	10	52	60	3.11.45.03



Connecting Elements

Anchor Connector

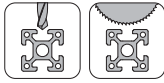

Material: zinc plated steel



Oblique (Model P)

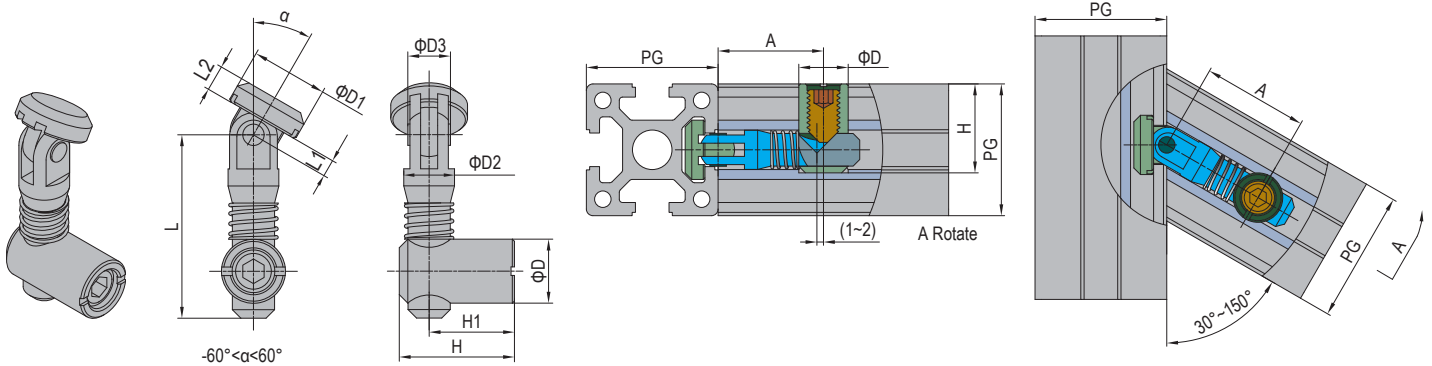

Description	A	D	H	H1	L1	L2	D1	D2	D3	L	Mass	Part No.
PG30-Oblique (Model P)	30	12	21	15	2.2	5	14	9.9	8	38.8	55	3.11.30.04
PG40-Oblique (Model P)	32	15	27	20	4	6	18	11.9	10	43	72	3.11.40.04
PG45-Oblique (Model P)	32	15	29.5	22.5	6	5	18	11.9	10	43	78	3.11.45.04

Oblique (Model C)

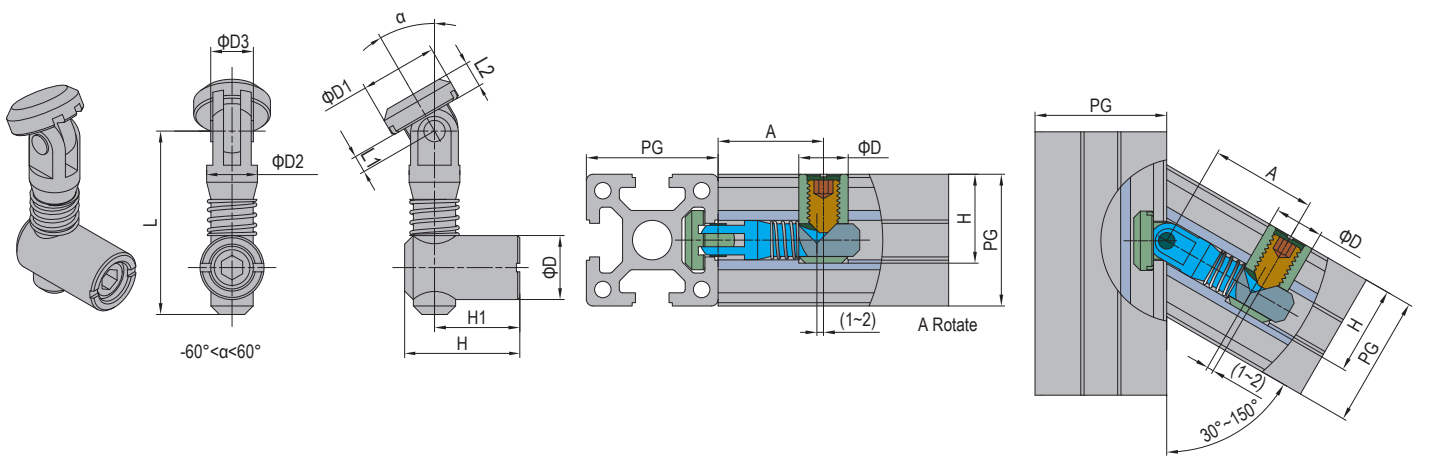

Description	A	D	H	H1	L1	L2	D1	D2	D3	L	Mass	Part No.
PG30-Oblique (Model C)	30	12	21	15	2.2	5	14	9.9	8	38.8	55	3.11.30.05
PG40-Oblique (Model C)	32	15	27	20	4	6	18	11.9	10	43	72	3.11.40.05
PG45-Oblique (Model C)	32	15	29.5	22.5	6	5	18	11.9	10	43	78	3.11.45.05

Connecting Elements



Material: zinc plated steel



Miter (Model P)

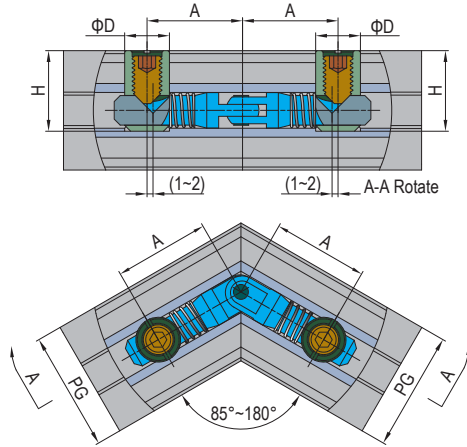
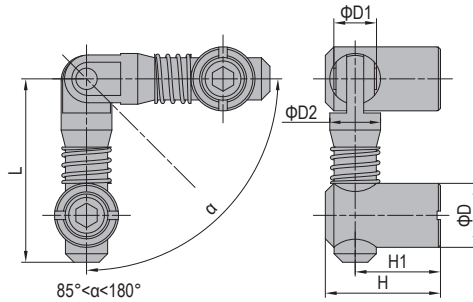
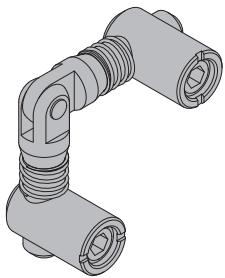

Description	A	D	H	H1	D1	D2	L	Mass	Part No.
PG30-Miter (Model P)	30	12	21	15	8	9.9	38.8	63	3.11.30.06
PG40-Miter (Model P)	32	15	27	20	10	11.9	43	97	3.11.40.06
PG45-Miter (Model P)	32	15	29.5	22.5	10	11.9	43	100	3.11.45.06

Miter (Model C)

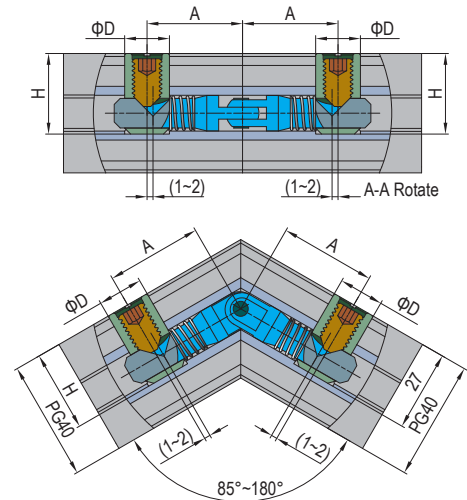
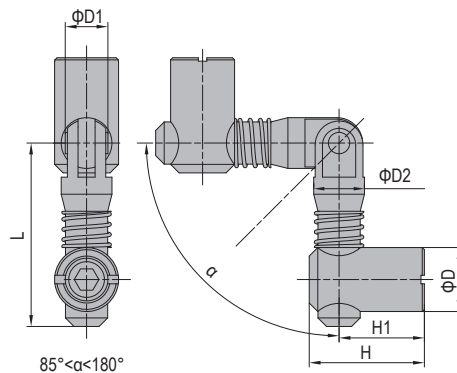
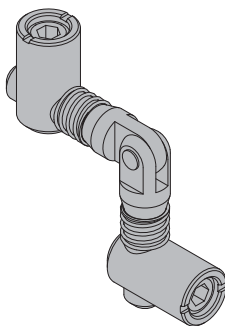

Description	A	D	H	H1	D1	D2	L	Mass	Part No.
PG30-Miter (Model C)	30	12	21	15	8	9.9	38.8	63	3.11.30.07
PG40-Miter (Model C)	32	15	27	20	10	11.9	43	97	3.11.40.07
PG45-Miter (Model C)	32	15	29.5	22.5	10	11.9	43	100	3.11.45.07

Connecting Elements

Die Cast Bracket

Material: diecast aluminum



PG20-20x20

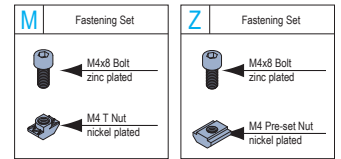
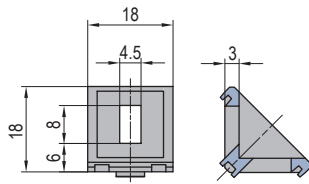

Description	Fastening Set	Mass (g)	Part No.
PG20-20x20 (pcs)		5	3.21.20.2020
PG20-20x20 (set M)	2xM	12	3.21.20.2020.STM
PG20-20x20 (set Z)	2xZ		3.21.20.2020.STZ

Connecting Elements

Die Cast Bracket

Material: diecast aluminum



PG30-30x30

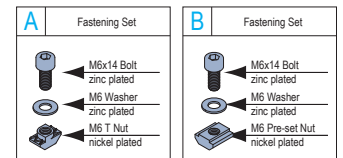
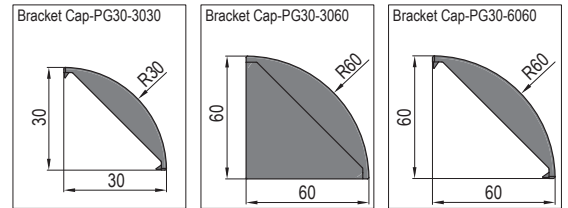
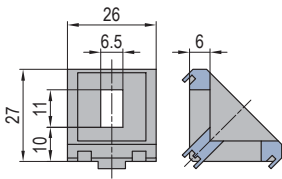

PG30-30x60

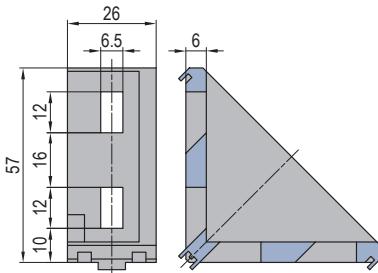

PG30-60x60

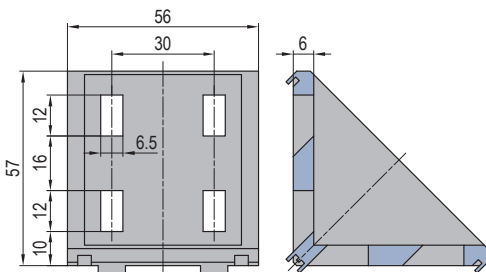

Description	Fastening Set	Mass (g)	Part No.
PG30-30x30 (pcs)		21	3.21.30.3030
PG30-30x30 (set A)	2xA	42	3.21.30.3030.STA
PG30-30x30 (set B)	2xB	48	3.21.30.3030.STB
Bracket Cap-PG30-3030		3	3.22.30.3030
PG30-30x60 (pcs)		53	3.21.30.3060
PG30-30x60 (set A)	4xA	93	3.21.30.3060.STA
PG30-30x60 (set B)	4xB	105	3.21.30.3060.STB
Bracket Cap-PG30-3060		12.4	3.22.30.3060
PG30-60x60 (pcs)		120	3.21.30.6060
PG30-60x60 (set A)	8xA	200	3.21.30.6060.STA
PG30-60x60 (set B)	8xB	224	3.21.30.6060.STB
Bracket Cap-PG30-6060		13.9	3.22.30.6060

Connecting Elements

Die Cast Bracket

Material: diecast aluminum



PG40-40x40

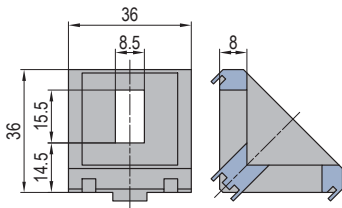

PG40-40x80

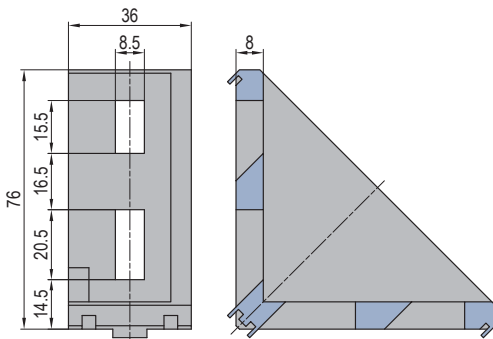

PG40-80x80

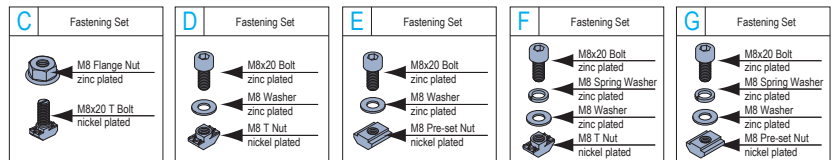
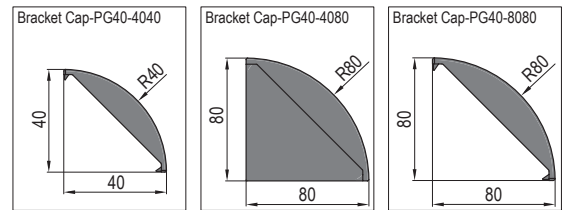
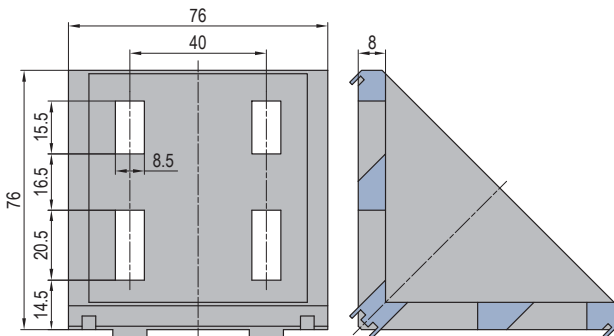

Description	Fastening Set	Mass (g)	Part No.
PG40-40x40 (pcs)		50	3.21.40.4040
PG40-40x40 (set C)	2xC	92	3.21.40.4040.STC
PG40-40x40 (set D)	2xD	92	3.21.40.4040.STD
PG40-40x40 (set E)	2xE	106	3.21.40.4040.STE
Bracket Cap-PG40-4040		6	3.22.40.4040
PG40-40x80 (pcs)		125	3.21.40.4080
PG40-40x80 (set C)	4xC	210	3.21.40.4080.STC
PG40-40x80 (set F)	4xF	220	3.21.40.4080.STF
PG40-40x80 (set G)	4xG	250	3.21.40.4080.STG
Bracket Cap-PG40-4080		22.6	3.22.40.4080
PG40-80x80 (pcs)		260	3.21.40.8080
PG40-80x80 (set C)	8xC	428	3.21.40.8080.STC
PG40-80x80 (set F)	8xF	452	3.21.40.8080.STF
PG40-80x80 (set G)	8xG	508	3.21.40.8080.STG
Bracket Cap-PG40-8080		25.6	3.22.40.8080



Connecting Elements

Die Cast Bracket

Material: diecast aluminum



PG45-45x45

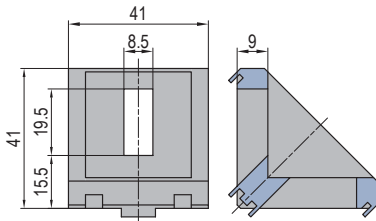

PG45-45x90

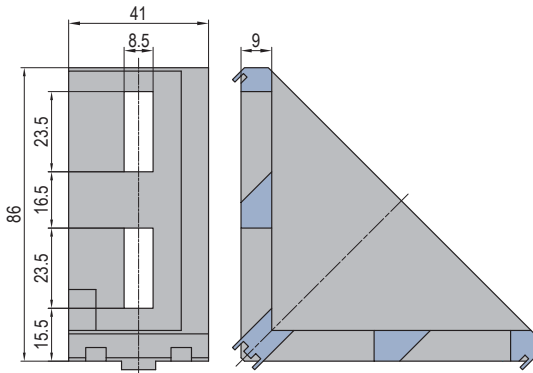

PG45-90x90

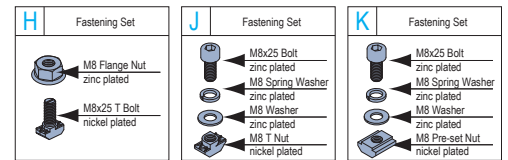
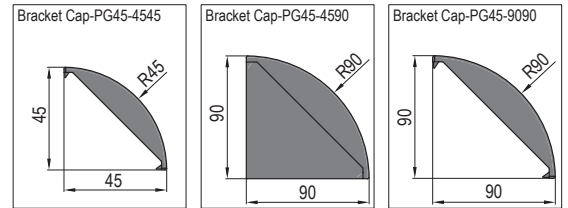
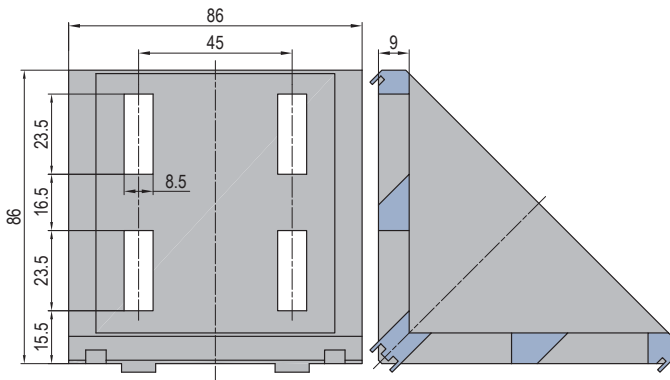

Description	Fastening Set	Mass (g)	Part No.
PG45-45x45 (pcs)		72	3.21.45.4545
PG45-45x45 (set H)	2xH	118	3.21.45.4545.STH
PG45-45x45 (set J)	2xJ	122	3.21.45.4545.STJ
PG45-45x45 (set K)	2xK	134	3.21.45.4545.STK
Bracket Cap-PG45-4545		7.6	3.22.45.4545
PG45-45x90 (pcs)		190	3.21.45.4590
PG45-45x90 (set H)	4xH	282	3.21.45.4590.STH
PG45-45x90 (set J)	4xJ	290	3.21.45.4590.STJ
PG45-45x90 (set K)	4xK	314	3.21.45.4590.STK
Bracket Cap-PG45-4590		28.7	3.22.45.4590
PG45-90x90 (pcs)		390	3.21.45.9090
PG45-90x90 (set H)	8xH	574	3.21.45.9090.STH
PG45-90x90 (set J)	8xJ	590	3.21.45.9090.STJ
PG45-90x90 (set K)	8xK	638	3.21.45.9090.STK
Bracket Cap-PG45-9090		32.5	3.22.45.9090



Connecting Elements

Die Cast Bracket

Material: diecast aluminum



PG50-50x50

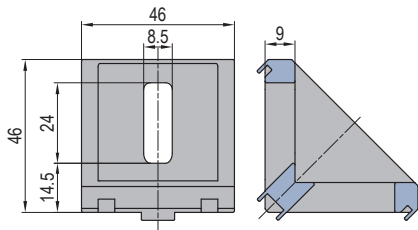

PG50-50x100

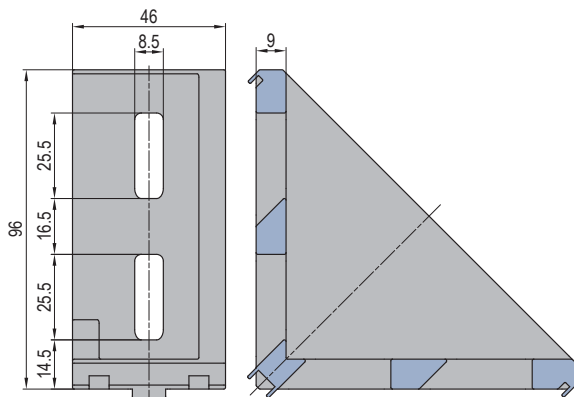

PG50-100x100

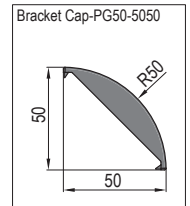
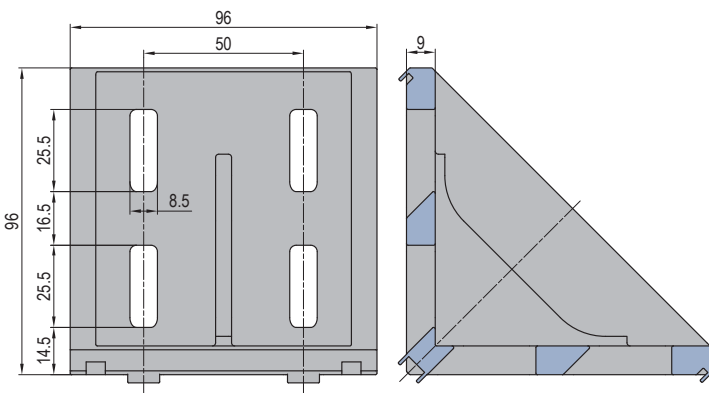

H	J	K
<p>Fastening Set</p> <ul style="list-style-type: none"> M8 Flange Nut zinc plated M8x25 T Bolt nickel plated 	<p>Fastening Set</p> <ul style="list-style-type: none"> M8x25 Bolt zinc plated M8 Spring Washer zinc plated M8 Washer zinc plated M8 T Nut nickel plated 	<p>Fastening Set</p> <ul style="list-style-type: none"> M8x25 Bolt zinc plated M8 Spring Washer zinc plated M8 Washer zinc plated M8 Pre-set Nut nickel plated

Description	Fastening Set	Mass (g)	Part No.
PG50-50x50 (pcs)		86	3.21.50.5050
PG50-50x50 (set H)	2xH	132	3.21.50.5050.STH
PG50-50x50 (set J)	2xJ	135	3.21.50.5050.STJ
PG50-50x50 (set K)	2xK	152	3.21.50.5050.STK
Bracket Cap-PG50-5050		9.5	3.22.50.5050
PG50-50x100 (pcs)		235	3.21.50.50100
PG50-50x100 (set H)	4xH	327	3.21.50.50100.STH
PG50-50x100 (set J)	4xJ	333	3.21.50.50100.STJ
PG50-50x100 (set K)	4xK	365	3.21.50.50100.STK
PG50-100x100 (pcs)		484	3.21.50.100100
PG50-100x100 (set H)	8xH	668	3.21.50.100100.STH
PG50-100x100 (set J)	8xJ	680	3.21.50.100100.STJ
PG50-100x100 (set K)	8xK	744	3.21.50.100100.STK

Connecting Elements





Angle Profile Bracket

Material: aluminium, anodized (cutting end not anodized)

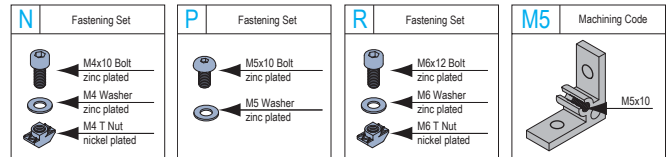
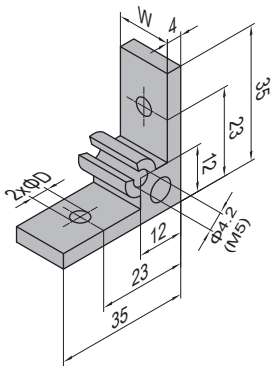

35x35x4



Application	Description	D (mm)	W (mm)	Fastening Set	Machining Code	Mass (g)	Part No.
PG15 15mm 	35-15-15 (pcs)	4.5	10			8	3.31.35.15.15
	35-15-15 (set)			2xN		20	3.31.35.15.15.ST
	35-15-15 (M5)				M5	8	3.31.35.15.15.M5
	35-15-15 (M5)			2xN+1xP	M5	22	3.31.35.15.15.M5.ST
PG15 30mm 	35-15-30 (pcs)	4.5	25			21	3.31.35.15.30
	35-15-30 (set)			2xN		33	3.31.35.15.30.ST
	35-15-30 (M5)				M5	21	3.31.35.15.30.M5
	35-15-30 (M5 set)			2xN+1xP	M5	35	3.31.35.15.30.M5.ST
PG20 20mm 	35-20-20 (pcs)	4.5	14			12	3.31.35.20.20
	35-20-20 (set)			2xN		24	3.31.35.20.20.ST
	35-20-20 (M5)				M5	12	3.31.35.20.20.M5
	35-20-20 (M5 set)			2xN+1xP	M5	26	3.31.35.20.20.M5.ST
PG30 30mm 	35-30-30 (pcs)	6.5	22			19	3.31.35.30.30
	35-30-30 (set)			2xR		42	3.31.35.30.30.ST
	35-30-30 (M5)				M5	19	3.31.35.30.30.M5
	35-30-30 (M5 set)			2xR+1xP	M5	44	3.31.35.30.30.M5.ST



Connecting Elements

Angle Profile Bracket

Material: aluminium, anodized (cutting end not anodized)



35x35x4

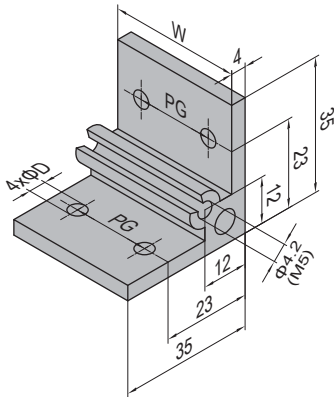

N	Fastening Set	P	Fastening Set	R	Fastening Set	M5	Machining Code
	 M4x10 Bolt zinc plated M4 Washer zinc plated M4 T Nut nickel plated	 M5x10 Bolt zinc plated M5 Washer zinc plated	 M6x12 Bolt zinc plated M6 Washer zinc plated M6 T Nut nickel plated	 M5x10			

Application	Description	D (mm)	W (mm)	PG (mm)	Fastening Set	Machining Code	Mass (g)	Part No.
PG20 40mm 	35-20-40 (pcs)	4.5	34	20			29	3.31.35.20.40
	35-20-40 (set)				4xN		50	3.31.35.20.40.ST
	35-20-40 (M5)					M5	29	3.31.35.20.40.M5
	35-20-40 (M5 set)				4xN+1xP	M5	52	3.31.35.20.40.M5.ST
PG30 60mm 	35-30-60 (pcs)	6.5	52	30			45	3.31.35.30.60
	35-30-60 (set)				4xR		88	3.31.35.30.60.ST
	35-30-60 (M5)					M5	45	3.31.35.30.60.M5
	35-30-60 (M5 set)				4xR+1xP	M5	90	3.31.35.30.60.M5.ST



Connecting Elements

Angle Profile Bracket

Material: aluminium, anodized (cutting end not anodized)



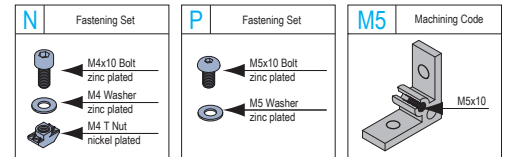
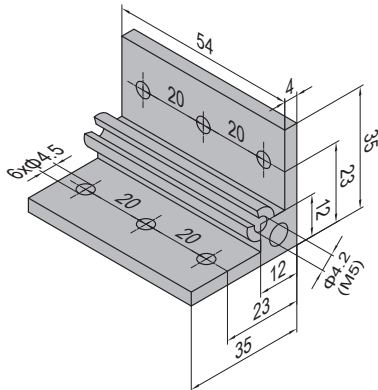

35x35x4

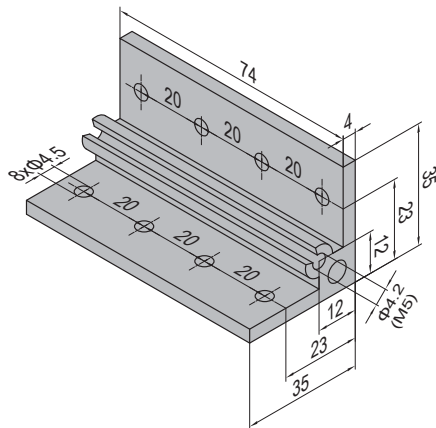

Application	Description	Fastening Set	Machining Code	Mass (g)	Part No.
PG20 60mm 	35-20-60 (pcs)			47	3.31.35.20.60
	35-20-60 (set)	6xN		77	3.31.35.20.60.ST
	35-20-60 (M5)		M5	47	3.31.35.20.60.M5
	35-20-60 (M5 set)	6xN+1xP	M5	79	3.31.35.20.60.M5.ST

35x35x4



Application	Description	Fastening Set	Machining Code	Mass (g)	Part No.
PG20 80mm 	35-20-80 (pcs)			64	3.31.35.20.80
	35-20-80 (set)	8xN		103	3.31.35.20.80.ST
	35-20-80 (M5)		M5	64	3.31.35.20.80.M5
	35-20-80 (M5 set)	8xN+1xP	M5	105	3.31.35.20.80.M5.ST

Connecting Elements







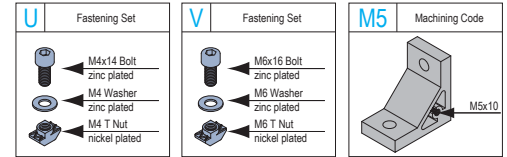
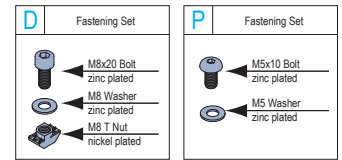
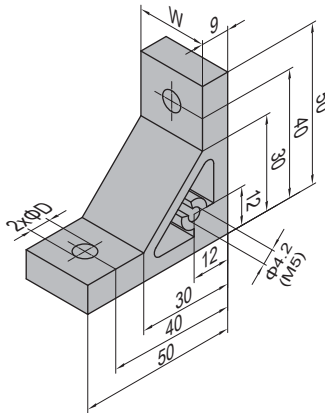

Angle Profile Bracket

Material: aluminium, anodized (cutting end not anodized)



50x50x9



Application	Description	D (mm)	W (mm)	Fastening Set	Machining Code	Mass (g)	Part No.
PG20 20mm 	50-20-20 (pcs)	4.5	14			31	3.31.50.20.20
	50-20-20 (set)			2xU		43	3.31.50.20.20.ST
	50-20-20 (M5)				M5	31	3.31.50.20.20.M5
	50-20-20 (M5 set)			2xU+1xP	M5	45	3.31.50.20.20.M5.ST
PG30 30mm 	50-30-30 (pcs)	6.5	22			48	3.31.50.30.30
	50-30-30 (set)			2xV		71	3.31.50.30.30.ST
	50-30-30 (M5)				M5	48	3.31.50.30.30.M5
	50-30-30 (M5 set)			2xV+1xP	M5	73	3.31.50.30.30.M5.ST
PG40 40mm 	50-40-40 (pcs)	8.5	30			66	3.31.50.40.40
	50-40-40 (set)			2xD		112	3.31.50.40.40.ST
	50-40-40 (M5)				M5	66	3.31.50.40.40.M5
	50-40-40 (M5 set)			2xD+1xP	M5	114	3.31.50.40.40.M5.ST
PG40 60mm 	50-40-60 (pcs/)	8.5	50			110	3.31.50.40.60
	50-40-60 (set)			2xD		156	3.31.50.40.60.ST
	50-40-60 (M5)				M5	110	3.31.50.40.60.M5
	50-40-60 (M5 set)			2xD+1xP	M5	158	3.31.50.40.60.M5.ST
PG45 45mm 	50-45-45 (pcs)	8.5	35			77	3.31.50.45.45
	50-45-45 (set)			2xD		123	3.31.50.45.45.ST
	50-45-45 (M5)				M5	77	3.31.50.45.45.M5
	50-45-45 (M5 set)			2xD+1xP	M5	125	3.31.50.45.45.M5.ST
PG45 60mm 	50-45-60 (pcs)	8.5	50			110	3.31.50.45.60
	50-45-60 (set)			2xD		156	3.31.50.45.60.ST
	50-45-60 (M5)				M5	110	3.31.50.45.60.M5
	50-45-60 (M5 Set)			2xD+1xP	M5	158	3.31.50.45.60.M5.ST
PG50 50mm 	50-50-50 (pcs)	8.5	40			88	3.31.50.50.50
	50-50-50 (set)			2xD		134	3.31.50.50.50.ST
	50-50-50 (M5)				M5	88	3.31.50.50.50.M5
	50-50-50 (M5 Set)			2xD+1xP	M5	136	3.31.50.50.50.M5.ST
PG60 60mm 	50-60-60 (pcs)	8.5	50			110	3.31.50.60.60
	50-60-60 (set)			2xD		156	3.31.50.60.60.ST
	50-60-60 (M5)				M5	110	3.31.50.60.60.M5
	50-60-60 (M5 Set)			2xD+1xP	M5	158	3.31.50.60.60.M5.ST



Connecting Elements

Angle Profile Bracket

Material: aluminium, anodized (cutting end not anodized)



50x50x9

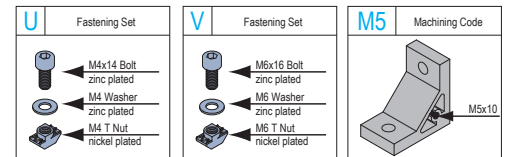
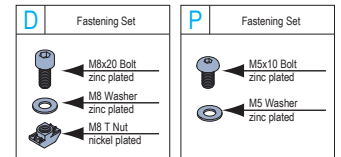
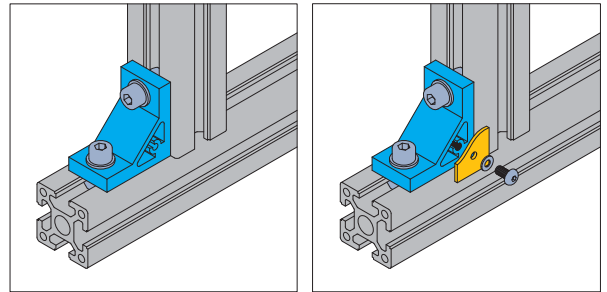
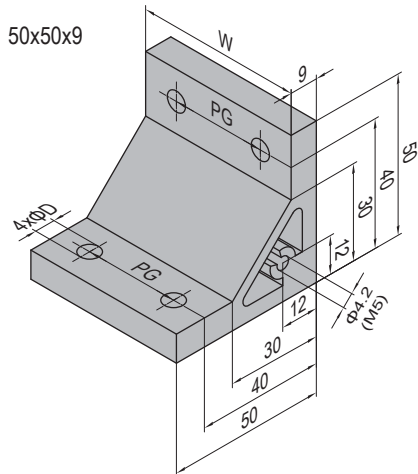

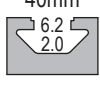
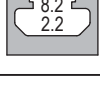
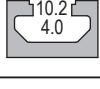
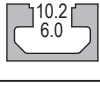
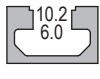
Application	Description	D (mm)	W (mm)	PG (mm)	Fastening Set	Machining Code	Mass (g)	Part No.
PG20 40mm 	50-20-40 (pcs)	4.5	34	20			75	3.31.50.20.40
	50-20-40 (set)				4xU		95	3.31.50.20.40.ST
	50-20-40 (M5)					M5	75	3.31.50.20.40.M5
	50-20-40 (M5 set)				4xU+1xP	M5	97	3.31.50.20.40.M5.ST
PG30 60mm 	50-30-60 (pcs)	6.5	52	30			114	3.31.50.30.60
	50-30-60 (set)				4xV		156	3.31.50.30.60.ST
	50-30-60 (M5)					M5	114	3.31.50.30.60.M5
	50-30-60 (M5 set)				4xV+1xP	M5	158	3.31.50.30.60.M5.ST
PG40 80mm 	50-40-80 (pcs)	8.5	70	40			154	3.31.50.40.80
	50-40-80 (set)				4xD		240	3.31.50.40.80.ST
	50-40-80 (M5)					M5	154	3.31.50.40.80.M5
	50-40-80 (M5 set)				4xD+1xP	M5	242	3.31.50.40.80.M5.ST
PG45 90mm 	50-45-90 (pcs)	8.5	80	45			176	3.31.50.45.90
	50-45-90 (set)				4xD		262	3.31.50.45.90.ST
	50-45-90 (M5)					M5	176	3.31.50.45.90.M5
	50-45-90 (M5 set)				4xD+1xP	M5	264	3.31.50.45.90.M5.ST
PG50 100mm 	50-50-100 (pcs)	8.5	90	50			198	3.31.50.50.100
	50-50-100 (set)				4xD		284	3.31.50.50.100.ST
	50-50-100 (M5)					M5	198	3.31.50.50.100.M5
	50-50-100 (M5 set)				4xD+1xP	M5	286	3.31.50.50.100.M5.ST



Connecting Elements

Angle Profile Bracket

Material: aluminium, anodized (cutting end not anodized)



50x50x9

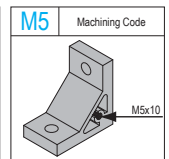
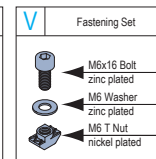
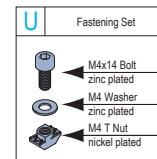
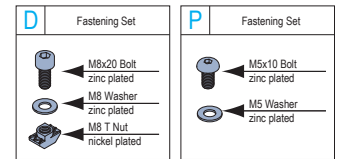
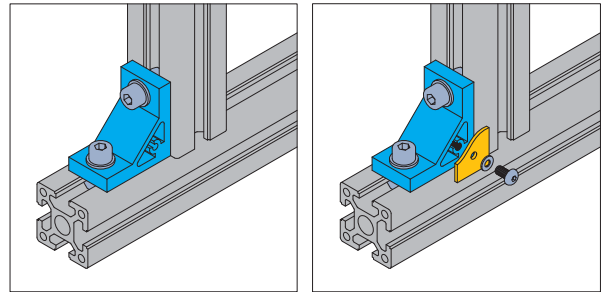
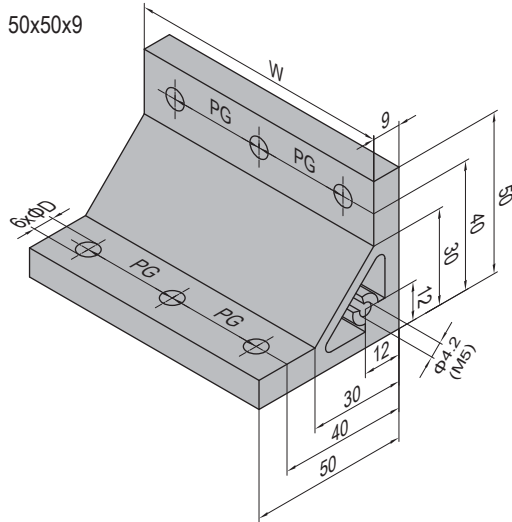

Application	Description	D (mm)	W (mm)	PG (mm)	Fastening Set	Machining Code	Mass (g)	Part No.
PG20 60mm 	50-20-60 (pcs)	4.5	54	20			119	3.31.50.20.60
	50-20-60 (set)				6xU		147	3.31.50.20.60.ST
	50-20-60 (M5)					M5	119	3.31.50.20.60.M5
	50-20-60 (M5 set)				6xU+1xP	M5	149	3.31.50.20.60.M5.ST
PG30 90mm 	50-30-90 (pcs)	6.5	82	30			180	3.31.50.30.90
	50-30-90 (set)				6xV		241	3.31.50.30.90.ST
	50-30-90 (M5)					M5	180	3.31.50.30.90.M5
	50-30-90 (M5 set)				6xV+1xP	M5	243	3.31.50.30.90.M5.ST
PG40 120mm 	50-40-120 (pcs)	8.5	110	40			242	3.31.50.40.120
	50-40-120 (set)				6xD		372	3.31.50.40.120.ST
	50-40-120 (M5)					M5	242	3.31.50.40.120.M5
	50-40-120 (M5 set)				6xD+1xP	M5	374	3.31.50.40.120.M5.ST



Connecting Elements

Angle Profile Bracket

Material: aluminium, anodized (cutting end not anodized)



50x50x9

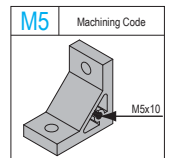
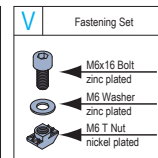
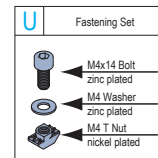
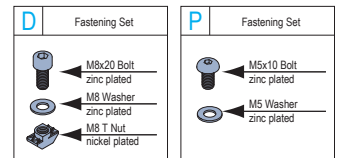
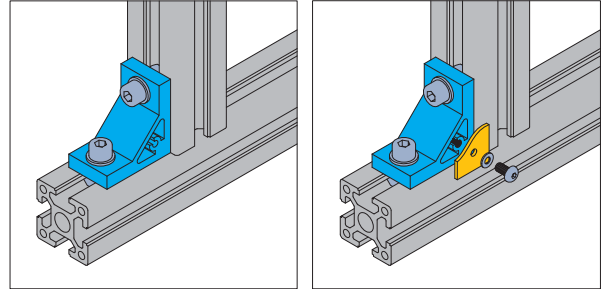
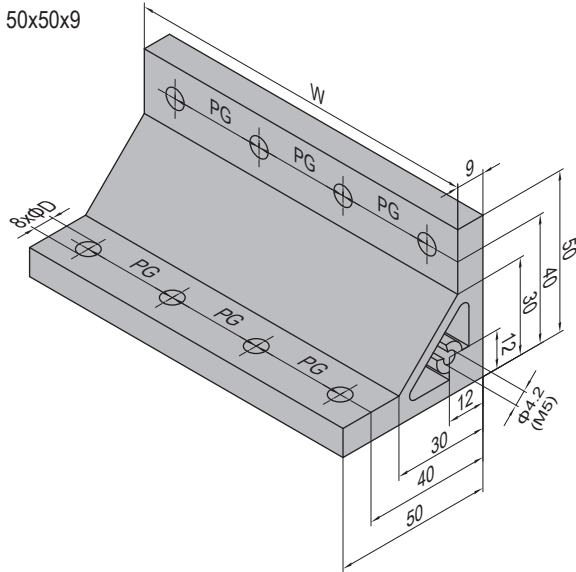

Application	Description	D (mm)	W (mm)	PG (mm)	Fastening Set	Machining Code	Mass (g)	Part No.
PG20 80mm 	50-20-80 (pcs)	4.5	74	20			163	3.31.50.20.80
	50-20-80 (set)				8xU		199	3.31.50.20.80.ST
	50-20-80 (M5 set)					M5	163	3.31.50.20.80.M5
	50-20-80 (M5 set)				8xU+1xP	M5	201	3.31.50.20.80.M5.ST
PG30 120mm 	50-30-120 (pcs)	6.5	112	30			246	3.31.50.30.120
	50-30-120 (set)				8xV		326	3.31.50.30.120.ST
	50-30-120 (M5)					M5	246	3.31.50.30.120.M5
	50-30-120 (M5 set)				8xV+1xP	M5	328	3.31.50.30.120.M5.ST
PG40 160mm 	50-40-160 (pcs)	8.5	150	40			330	3.31.50.40.160
	50-40-160 (set)				8xD		502	3.31.50.40.160.ST
	50-40-160 (M5)					M5	330	3.31.50.40.160.M5
	50-40-160 (M5 set)				8xD+1xP	M5	504	3.31.50.40.160.M5.ST
PG45 180mm 	50-45-180 (pcs)	8.5	170	45			374	3.31.50.45.180
	50-45-180 (set)				8xD		546	3.31.50.45.180.ST
	50-45-180 (M5)					M5	374	3.31.50.45.180.M5
	50-45-180 (M5 set)				8xD+1xP	M5	548	3.31.50.45.180.M5.ST



Connecting Elements

Angle Profile Bracket





Material: aluminium, anodized (cutting end not anodized)

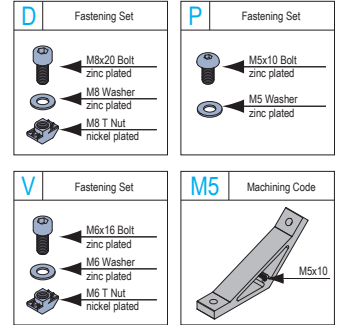
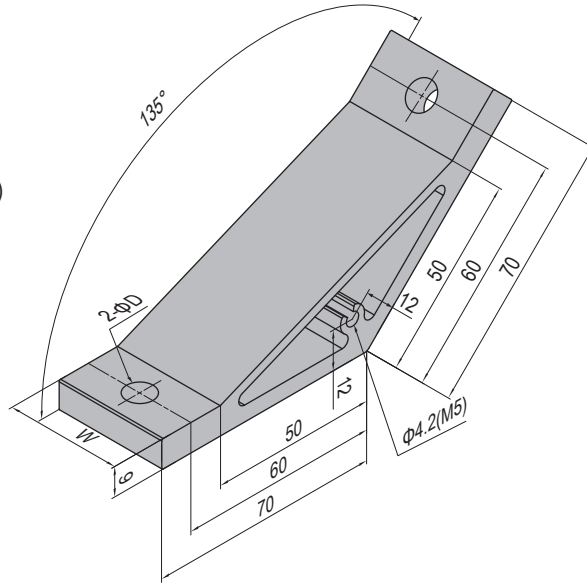

70x70x9-135°

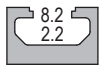
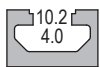
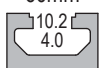
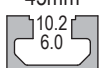
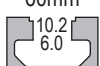

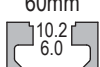
Application	Description	D (mm)	W (mm)	Fastening Set	Machining Code	Mass (g)	Part No.
PG30 30mm 	70-30-30 (pcs)	7	22			71	3.31.70.30.30
	70-30-30 (set)			2xV		94	3.31.70.30.30.ST
	70-30-30 (M5)				M5	71	3.31.70.30.30.M5
	70-30-30 (M5 set)			2xV+1xP	M5	96	3.31.70.30.30.M5.ST
PG40 40mm 	70-40-40 (pcs)	9	30			96	3.31.70.40.40
	70-40-40 (set)			2xD		142	3.31.70.40.40.ST
	70-40-40 (M5)				M5	96	3.31.70.40.40.M5
	70-40-40 (M5 set)			2xD+1xP	M5	144	3.31.70.40.40.M5.ST
PG40 60mm 	70-40-60 (pcs)	9	50			166	3.31.70.40.60
	70-40-60 (set)			2xD		212	3.31.70.40.60.ST
	70-40-60 (M5)				M5	166	3.31.70.40.60.M5
	70-40-60 (M5 set)			2xD+1xP	M5	214	3.31.70.40.60.M5.ST
PG45 45mm 	70-45-45 (pcs)	9	35			113	3.31.70.45.45
	70-45-45 (set)			2xD		159	3.31.70.45.45.ST
	70-45-45 (M5)				M5	113	3.31.70.45.45.M5
	70-45-45 (M5 set)			2xD+1xP	M5	161	3.31.70.45.45.M5.ST
PG45 60mm 	70-45-60 (pcs)	9	50			166	3.31.70.45.60
	70-45-60 (set)			2xD		212	3.31.70.45.60.ST
	70-45-60 (M5)				M5	166	3.31.70.45.60.M5
	70-45-60 (M5 Set)			2xD+1xP	M5	214	3.31.70.45.60.M5.ST
PG50 50mm 	70-50-50 (pcs)	9	40			131	3.31.70.50.50
	70-50-50 (set)			2xD		177	3.31.70.50.50.ST
	70-50-50 (M5)				M5	131	3.31.70.50.50.M5
	70-50-50 (M5 Set)			2xD+1xP	M5	179	3.31.70.50.50.M5.ST
PG60 60mm 	70-60-60 (pcs)	9	50			166	3.31.70.60.60
	70-60-60 (set)			2xD		212	3.31.70.60.60.ST
	70-60-60 (M5)				M5	166	3.31.70.60.60.M5
	70-60-60 (M5 Set)			2xD+1xP	M5	214	3.31.70.60.60.M5.ST



Connecting Elements

Angle Profile Bracket







Material: aluminium, anodized (cutting end not anodized)

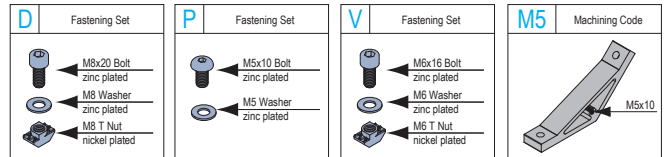
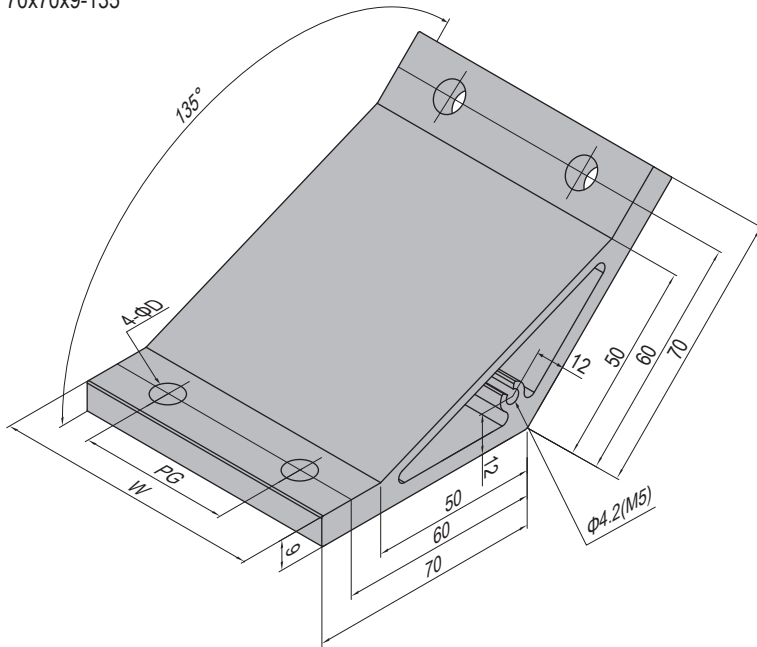

70x70x9-135°



Application	Description	D (mm)	W (mm)	PG (mm)	Fastening Set	Machining Code	Mass (g)	Part No.
PG30 60mm 	70-30-60 (pcs)	7	52	30			171	3.31.70.30.60
	70-30-60 (set)				4xD		213	3.31.70.30.60.ST
	70-30-60 (M5)					M5	171	3.31.70.30.60.M5
	70-30-60 (M5 set)				4xV+1xP	M5	215	3.31.70.30.60.M5.ST
PG40 80mm 	70-40-80 (pcs)	9	70	40			227	3.31.70.40.80
	70-40-80 (set)				4xD		313	3.31.70.40.80.ST
	70-40-80 (M5)					M5	227	3.31.70.40.80.M5
	70-40-80 (M5 set)				4xD+1xP	M5	315	3.31.70.40.80.M5.ST
PG45 90mm 	70-45-90 (pcs)	9	80	45			262	3.31.70.45.90
	70-45-90 (set)				4xD		348	3.31.70.45.90.ST
	70-45-90 (M5)					M5	262	3.31.70.45.90.M5
	70-45-90 (M5 set)				4xD+1xP	M5	350	3.31.70.45.90.M5.ST
PG50 100mm 	70-50-100 (pcs)	9	90	50			297	3.31.70.50.100
	70-50-100 (set)				4xD		383	3.31.70.50.100.ST
	70-50-100 (M5)					M5	297	3.31.70.50.100.M5
	70-50-100 (M5 set)				4xD+1xP	M5	385	3.31.70.50.100.M5.ST



Connecting Elements

Angle Profile Bracket



Material: aluminium, anodized (cutting end not anodized)



70x70x9-135°

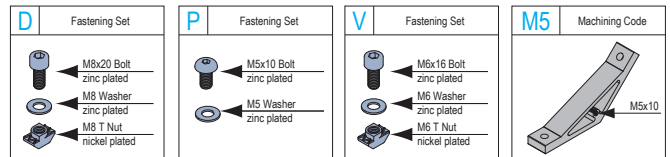
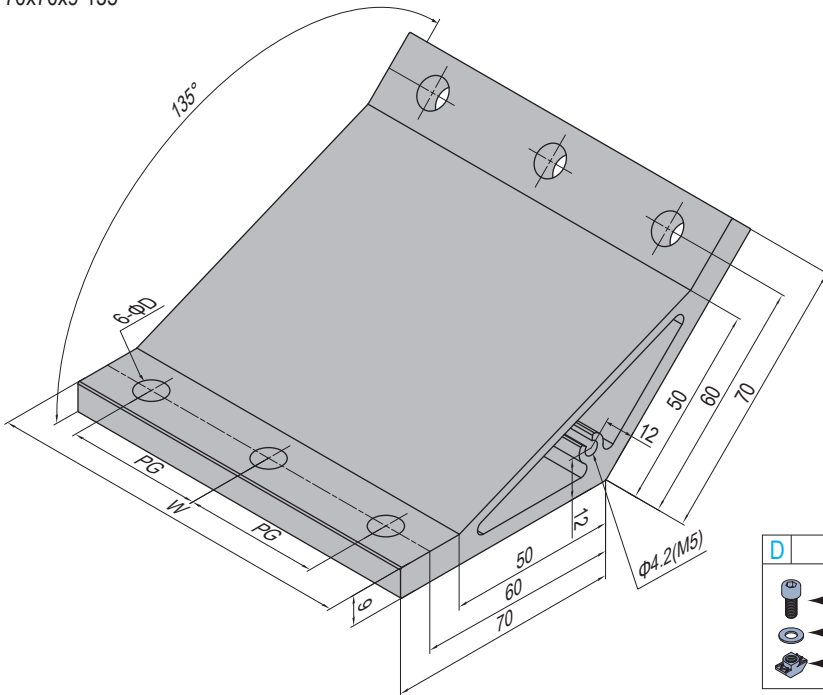

Application	Description	D (mm)	W (mm)	PG (mm)	Fastening Set	Machining Code	Mass (g)	Part No.
PG30 90mm 	70-30-90 (pcs)	7	82	30			270	3.31.70.30.90
	70-30-90 (set)				6xV		331	3.31.70.30.90.ST
	70-30-90 (M5)					M5	270	3.31.70.30.90.M5
	70-30-90 (M5 set)				6xV+1xP	M5	333	3.31.70.30.90.M5.ST
PG40 120mm 	70-40-120 (pcs)	9	110	40			357	3.31.70.40.120
	70-40-120 (set)				6xD		487	3.31.70.40.120.ST
	70-40-120 (M5)					M5	357	3.31.70.40.120.M5
	70-40-120 (M5 set)				6xD+1xP	M5	489	3.31.70.40.120.M5.ST



Connecting Elements









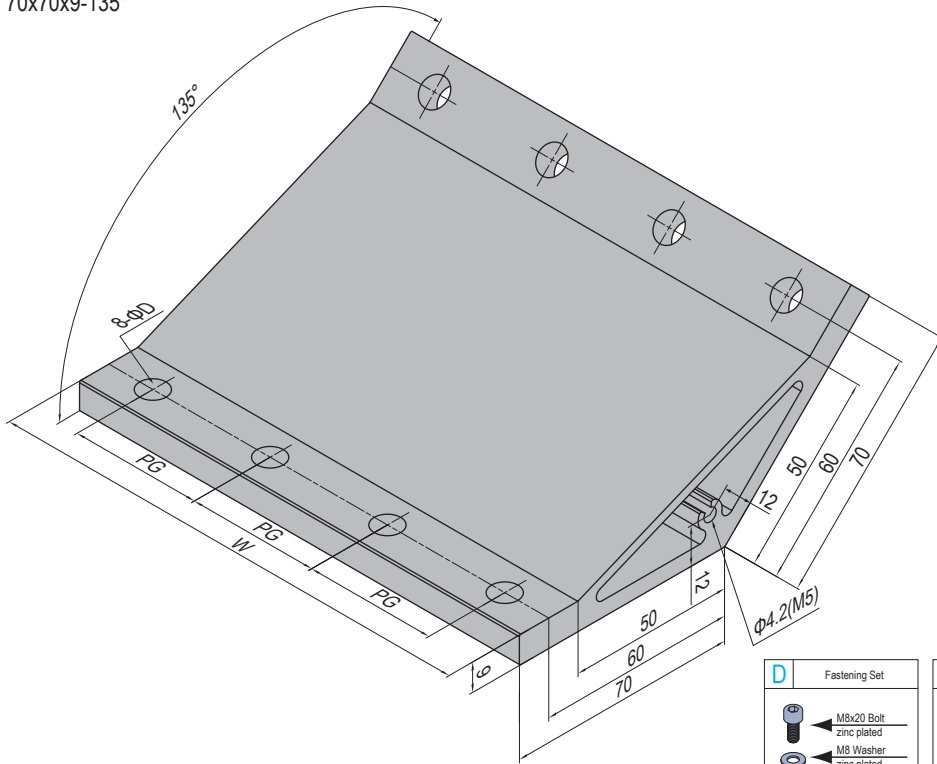

Material: aluminium, anodized (cutting end not anodized)



70x70x9-135°

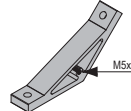

D Fastening Set	P Fastening Set	V Fastening Set	M5 Machining Code
 M8x20 Bolt zinc plated  M8 Washer zinc plated  M8 T Nut nickel plated	 M5x10 Bolt zinc plated  M5 Washer zinc plated	 M6x16 Bolt zinc plated  M6 Washer zinc plated  M6 T Nut nickel plated	 M5x10

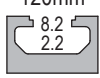
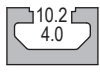
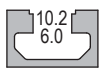
Application	Description	D (mm)	W (mm)	PG (mm)	Fastening Set	Machining Code	Mass (g)	Part No.
PG30 120mm 	70-30-120 (pcs)	7	112	30			369	3.31.70.30.120
	70-30-120 (set)				8xV		449	3.31.70.30.120.ST
	70-30-120 (M5)					M5	369	3.31.70.30.120.M5
	70-30-120 (M5 set)				8xV+1xP	M5	451	3.31.70.30.120.M5.ST
PG40 160mm 	70-40-160 (pcs)	9	150	40			488	3.31.70.40.160
	70-40-160 (set)				8xD		660	3.31.70.40.160.ST
	70-40-160 (M5)					M5	488	3.31.70.40.160.M5
	70-40-160 (M5 set)				8xD+1xP	M5	662	3.31.70.40.160.M5.ST
PG45 180mm 	70-45-180 (pcs)	9	170	45			558	3.31.70.45.180
	70-45-180 (set)				8xD		730	3.31.70.45.180.ST
	70-45-180 (M5)					M5	558	3.31.70.45.180.M5
	70-45-180 (M5 set)				8xD+1xP	M5	732	3.31.70.45.180.M5.ST



Connecting Elements

Angle Profile Bracket





Material: aluminium, anodized (cutting end not anodized)

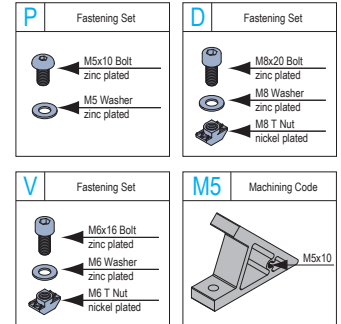
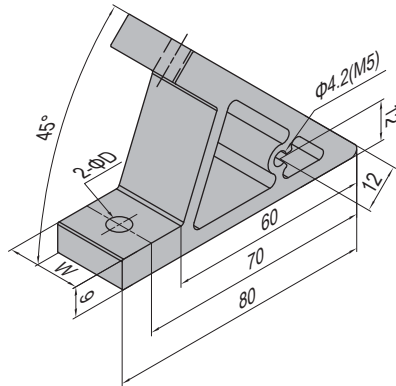

80x80x9-45°

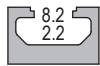
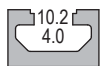
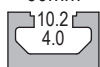
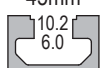
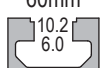
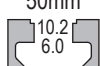

Application	Description	D (mm)	W (mm)	Fastening Set	Machining Code	Mass (g)	Part No.
PG30 30mm 	80-30-30 (pcs)	7	22			68	3.31.80.30.30
	80-30-30 (set)			2xV		91	3.31.80.30.30.ST
	80-30-30 (M5)				M5	68	3.31.80.30.30.M5
	80-30-30 (M5 set)			2xV+1xP	M5	93	3.31.80.30.30.M5.ST
PG40 40mm 	80-40-40 (pcs)	9	30			89	3.31.80.40.40
	80-40-40 (set)			2xD		135	3.31.80.40.40.ST
	80-40-40 (M5)				M5	89	3.31.80.40.40.M5
	80-40-40 (M5 set)			2xD+1xP	M5	137	3.31.80.40.40.M5.ST
PG40 60mm 	80-40-60 (pcs)	9	50			151	3.31.80.40.60
	80-40-60 (set)			2xD		197	3.31.80.40.60.ST
	80-40-60 (M5)				M5	151	3.31.80.40.60.M5
	80-40-60 (M5 set)			2xD+1xP	M5	199	3.31.80.40.60.M5.ST
PG45 45mm 	80-45-45 (pcs)	9	35			105	3.31.80.45.45
	80-45-45 (set)			2xD		151	3.31.80.45.45.ST
	80-45-45 (M5)				M5	105	3.31.80.45.45.M5
	80-45-45 (M5 set)			2xD+1xP	M5	153	3.31.80.45.45.M5.ST
PG45 60mm 	80-45-60 (pcs)	9	50			151	3.31.80.45.60
	80-45-60 (set)			2xD		197	3.31.80.45.60.ST
	80-45-60 (M5)				M5	151	3.31.80.45.60.M5
	80-45-60 (M5 set)			2xD+1xP	M5	199	3.31.80.45.60.M5.ST
PG50 50mm 	80-50-50 (pcs)	9	50			120	3.31.80.50.50
	80-50-50 (set)			2xD		166	3.31.80.50.50.ST
	80-50-50 (M5)				M5	120	3.31.80.50.50.M5
	80-50-50 (M5 Set)			2xD+1xP	M5	168	3.31.80.50.50.M5.ST
PG60 60mm 	80-60-60 (pcs)	9	50			151	3.31.80.60.60
	80-60-60 (set)			2xD		197	3.31.80.60.60.ST
	80-60-60 (M5)				M5	151	3.31.80.60.60.M5
	80-60-60 (M5 Set)			2xD+1xP	M5	199	3.31.80.60.60.M5.ST



Connecting Elements

Angle Profile Bracket



Material: aluminium, anodized (cutting end not anodized)



80x80x9-45°

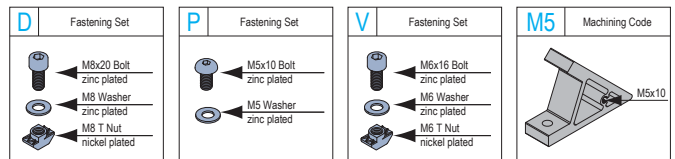
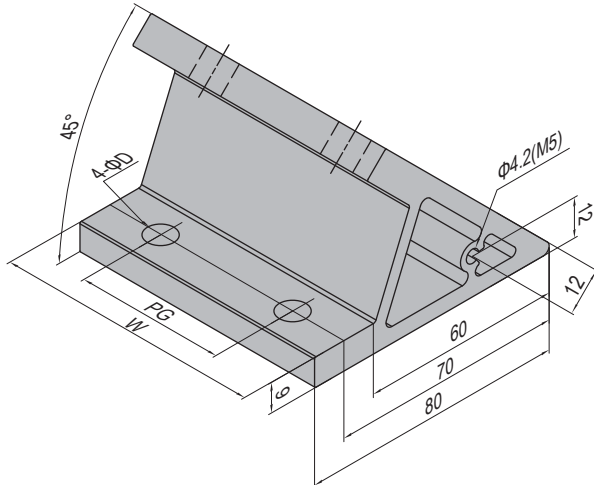

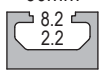
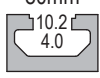
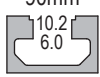
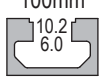
Application	Description	D (mm)	W (mm)	PG (mm)	Fastening Set	Machining Code	Mass (g)	Part No.
PG30 60mm 	80-30-60 (pcs)	7	52	30			156	3.31.80.30.60
	80-30-60 (set)				4xV		198	3.31.80.30.60.ST
	80-30-60 (M5)					M5	156	3.31.80.30.60.M5
	80-30-60 (M5 set)				4xV+1xP	M5	200	3.31.80.30.60.M5.ST
PG40 80mm 	80-40-80 (pcs)	9	70	40			209	3.31.80.40.80
	80-40-80 (set)				4xD		295	3.31.80.40.80.ST
	80-40-80 (M5)					M5	209	3.31.80.40.80.M5
	80-40-80 (M5 set)				4xD+1xP	M5	297	3.31.80.40.80.M5.ST
PG45 90mm 	80-45-90 (pcs)	9	80	45			240	3.31.80.45.90
	80-45-90 (set)				4xD		326	3.31.80.45.90.ST
	80-45-90 (M5)					M5	240	3.31.80.45.90.M5
	80-45-90 (M5 set)				4xD+1xP	M5	328	3.31.80.45.90.M5.ST
PG50 100mm 	80-50-100 (pcs)	9	90	50			271	3.31.80.50.100
	80-50-100 (set)				4xD		357	3.31.80.50.100.ST
	80-50-100 (M5)					M5	271	3.31.80.50.100.M5
	80-50-100 (M5 set)				4xD+1xP	M5	359	3.31.80.50.100.M5.ST



Connecting Elements

Angle Profile Bracket



Material: aluminium, anodized (cutting end not anodized)



80x80x9-45°

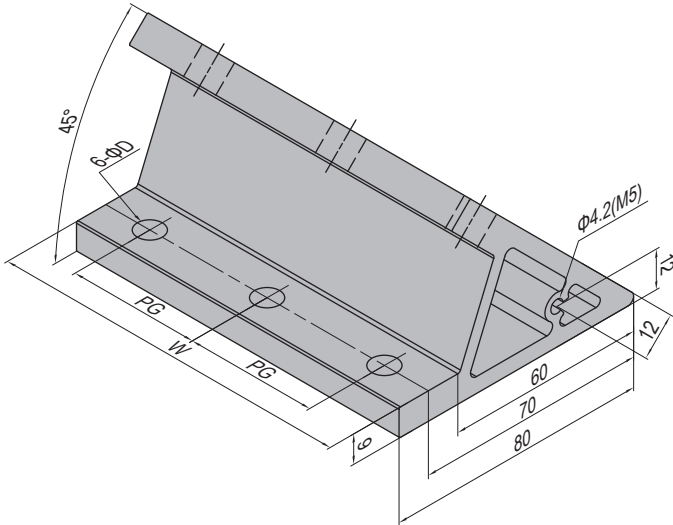

D Fastening Set	P Fastening Set	V Fastening Set	M5 Machining Code
<ul style="list-style-type: none"> M8x20 Bolt zinc plated M8 Washer zinc plated M8 T Nut nickel plated 	<ul style="list-style-type: none"> M5x10 Bolt zinc plated M5 Washer zinc plated 	<ul style="list-style-type: none"> M6x16 Bolt zinc plated M6 Washer zinc plated M6 T Nut nickel plated 	

Application	Description	D (mm)	W (mm)	PG (mm)	Fastening Set	Machining Code	Mass (g)	Part No.
PG30 90mm 	80-30-90 (pcs)	7	82	30			247	3.31.80.30.90
	80-30-90 (set)				6xV		308	3.31.80.30.90.ST
	80-30-90 (M5)					M5	247	3.31.80.30.90.M5
	80-30-90 (M5 set)				6xV+1xP	M5	310	3.31.80.30.90.M5.ST
PG40 120mm 	80-40-120 (pcs)	9	110	40			329	3.31.80.40.120
	80-40-120 (set)				6xD		459	3.31.80.40.120.ST
	80-40-120 (M5)					M5	329	3.31.80.40.120.M5
	80-40-120 (M5 set)				6xD+1xP	M5	461	3.31.80.40.120.M5.ST



Connecting Elements





Material: aluminium, anodized (cutting end not anodized)

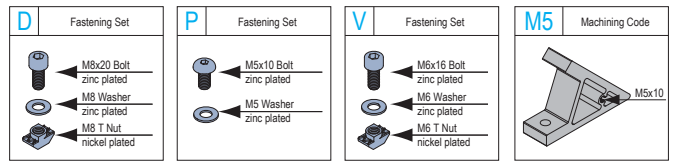
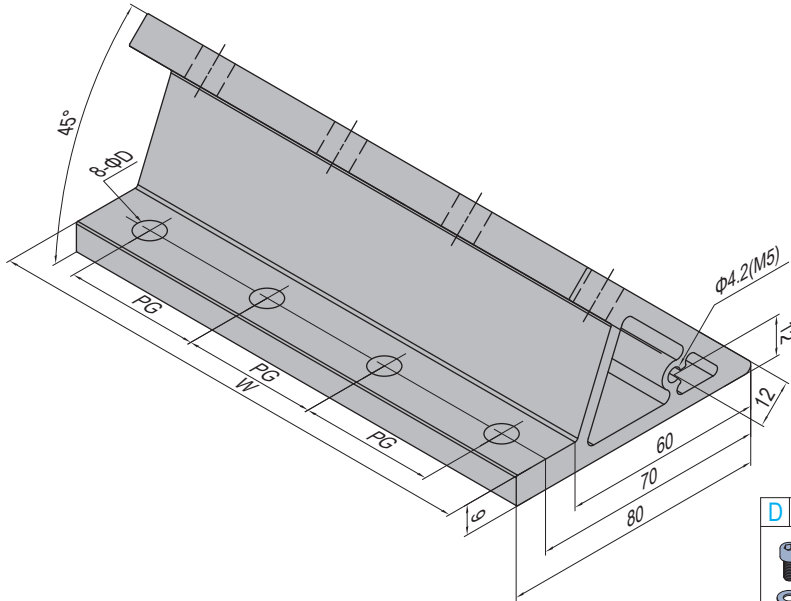

80x80x9-45°

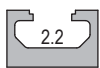
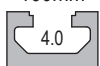

Application	Description	D (mm)	W (mm)	PG (mm)	Fastening Set	Machining Code	Mass (g)	Part No.
PG30 120mm 	80-30-120 (pcs)	7	112	30			337	3.31.80.30.120
	80-30-120 (set)				8xV		417	3.31.80.30.120.ST
	80-30-120 (M5)					M5	337	3.31.80.30.120.M5
	80-30-120 (M5 set)				8xV+1xP	M5	419	3.31.80.30.120.M5.ST
PG40 160mm 	80-40-160 (pcs)	9	150	40			449	3.31.80.40.160
	80-40-160 (set)				8xD		621	3.31.80.40.160.ST
	80-40-160 (M5)					M5	449	3.31.80.40.160.M5
	80-40-160 (M5 set)				8xD+1xP	M5	623	3.31.80.40.160.M5.ST
PG45 180mm 	80-45-180 (pcs)	9	170	45			510	3.31.80.45.180
	80-45-180 (set)				8xD		682	3.31.80.45.180.ST
	80-45-180 (M5)					M5	510	3.31.80.45.180.M5
	80-45-180 (M5 set)				8xD+1xP	M5	684	3.31.80.45.180.M5.ST



Connecting Elements

Angle Profile Bracket

Material: aluminium, anodized



100x100x15

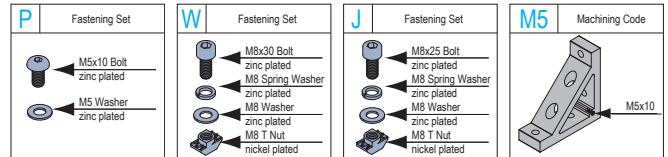
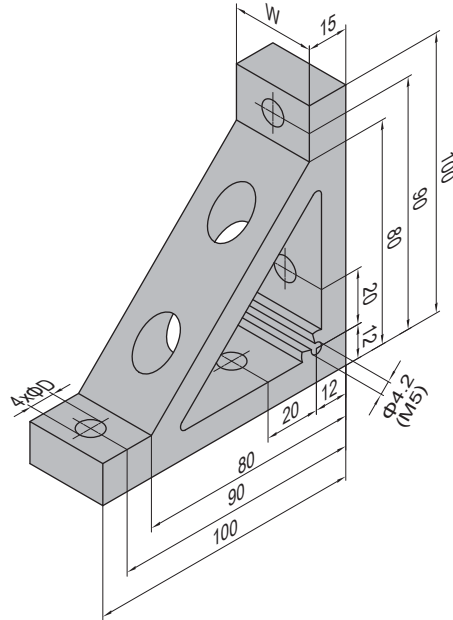

Application	Description	D (mm)	W (mm)	Fastening Set	Machining Code	Mass (g)	Part No.
PG40 40mm 	100-40-40 (pcs)	9	30			220	3.31.100.40.40
	100-40-40 (set)			2xW+2xJ		324	3.31.100.40.40.ST
	100-40-40 (M5)				M5	220	3.31.100.40.40.M5
	100-40-40 (M5 set)			2xW+2xJ+1xP	M5	326	3.31.100.40.40.M5.ST
PG40 60mm 	100-40-60 (pcs)	9	50			386	3.31.100.40.60
	100-40-60 (set)			2xW+2xJ		490	3.31.100.40.60.ST
	100-40-60 (M5)				M5	386	3.31.100.40.60.M5
	100-40-60 (M5 set)			2xW+2xJ+1xP	M5	492	3.31.100.40.60.M5.ST
PG45 45mm 	100-45-45 (pcs)	9	35			261	3.31.100.45.45
	100-45-45 (set)			2xW+2xJ		365	3.31.100.45.45.ST
	100-45-45 (M5)				M5	261	3.31.100.45.45.M5
	100-45-45 (M5 set)			2xW+2xJ+1xP	M5	367	3.31.100.45.45.M5.ST
PG45 60mm 	100-45-60 (pcs)	9	50			386	3.31.100.45.60
	100-45-60 (set)			2xW+2xJ		490	3.31.100.45.60.ST
	100-45-60 (M5)				M5	386	3.31.100.45.60.M5
	100-45-60 (M5 set)			2xW+2xJ+1xP	M5	492	3.31.100.45.60.M5.ST
PG50 50mm 	100-50-50 (pcs)	9	40			303	3.31.100.50.50
	100-50-50 (set)			2xW+2xJ		407	3.31.100.50.50.ST
	100-50-50 (M5)				M5	303	3.31.100.50.50.M5
	100-50-50 (M5 set)			2xW+2xJ+1xP	M5	409	3.31.100.50.50.M5.ST
PG60 60mm 	100-60-60 (pcs)	9	50			386	3.31.100.60.60
	100-60-60 (set)			2xW+2xJ		490	3.31.100.60.60.ST
	100-60-60 (M5)				M5	386	3.31.100.60.60.M5
	100-60-60 (M5 Set)			2xW+2xJ+1xP	M5	492	3.31.100.60.60.M5.ST



Connecting Elements



Angle Profile Bracket

Material: aluminium, anodized

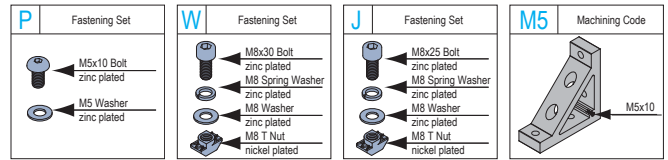
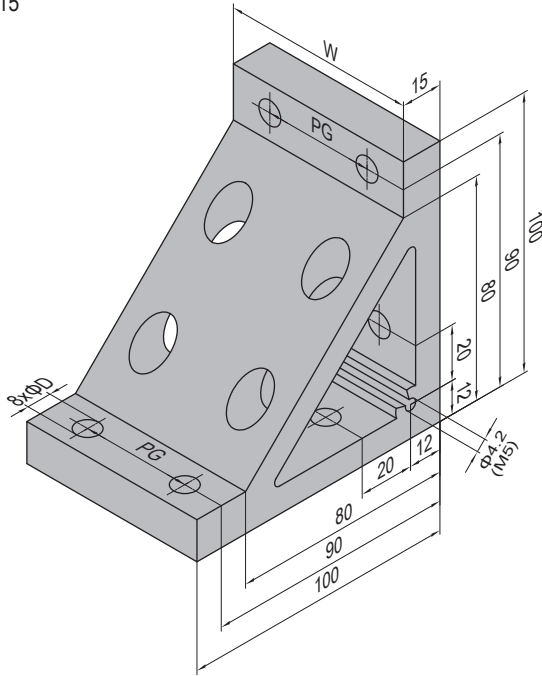

100x100x15



Application	Description	D (mm)	W (mm)	PG (mm)	Fastening Set	Machining Code	Mass (g)	Part No.
PG40 80mm 	100-40-80 (pcs)	9	70	40			522	3.31.100.40.80
	100-40-80 (set)				4xW+4xJ		730	3.31.100.40.80.ST
	100-40-80 (M5)					M5	522	3.31.100.40.80.M5
	100-40-80 (M5 set)				4xW+4xJ+1xP	M5	732	3.31.100.40.80.M5.ST
PG45 90mm 	100-45-90 (pcs)	9	80	45			605	3.31.100.45.90
	100-45-90 (set)				4xW+4xJ		813	3.31.100.45.90.ST
	100-45-90 (M5)					M5	605	3.31.100.45.90.M5
	100-45-90 (M5 set)				4xW+4xJ+1xP	M5	815	3.31.100.45.90.M5.ST
PG50 100mm 	100-50-100 (pcs)	9	90	50			688	3.31.100.50.100
	100-50-100 (set)				4xW+4xJ		896	3.31.100.50.100.ST
	100-50-100 (M5)					M5	688	3.31.100.50.100.M5
	100-50-100 (M5 set)				4xW+4xJ+1xP	M5	898	3.31.100.50.100.M5.ST



Connecting Elements

Angle Profile Bracket

Material: aluminium, anodized



100x100x15

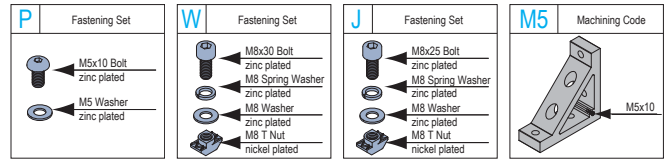
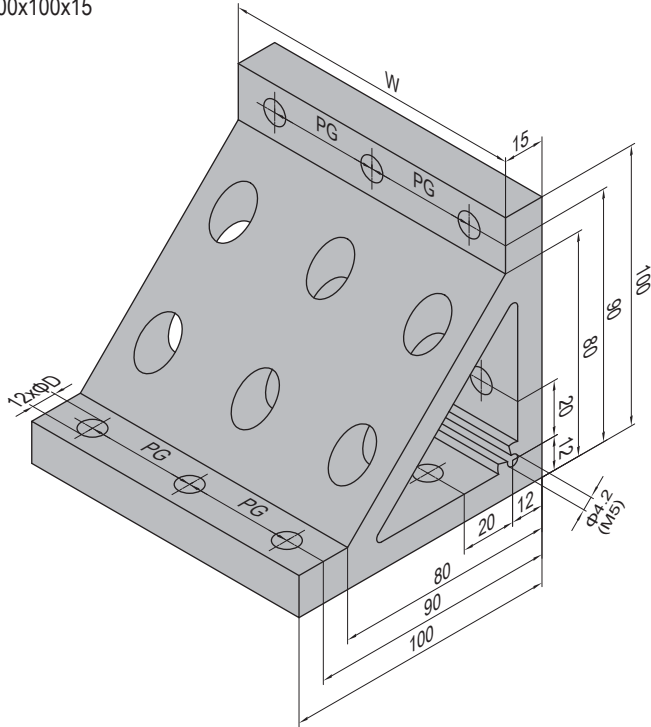

Application	Description	D (mm)	W (mm)	PG (mm)	Fastening Set	Machining Code	Mass (g)	Part No.
PG40 120mm 	100-40-120 (pcs)	9	110	40			824	3.31.100.40.120
	100-40-120 (set)				6xW+6xJ		1136	3.31.100.40.120.ST
	100-40-120 (M5)					M5	824	3.31.100.40.120.M5
	100-40-120 (M5 set)				6xW+6xJ+1xP	M5	1138	3.31.100.40.120.M5.ST



Connecting Elements



Angle Profile Bracket

Material: aluminium, anodized

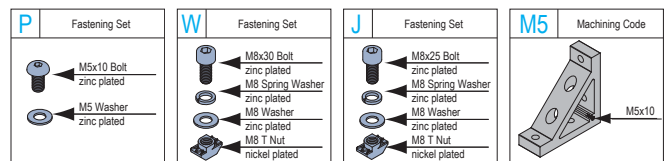
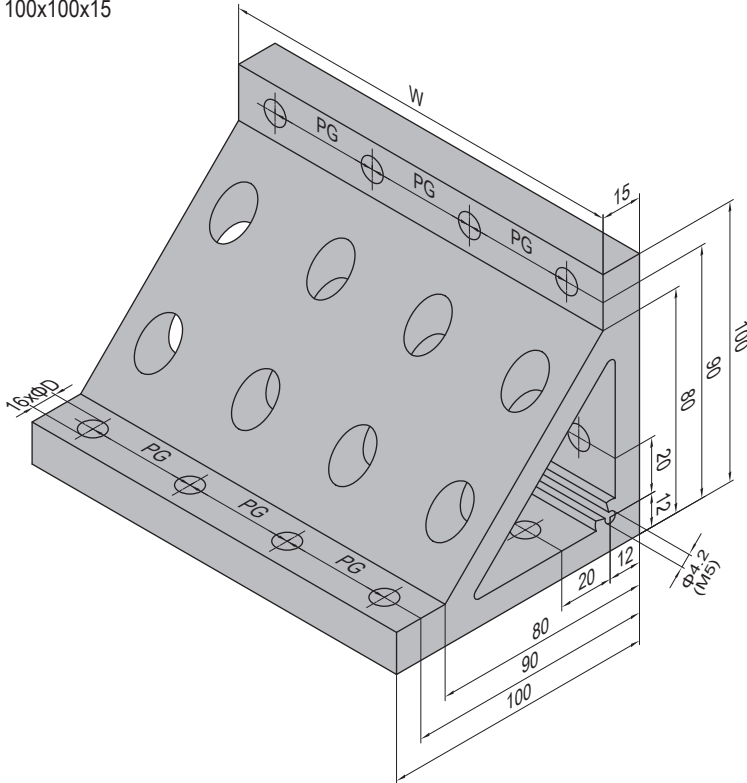

100x100x15



Application	Description	D (mm)	W (mm)	PG (mm)	Fastening Set	Machining Code	Mass (g)	Part No.
PG40 160mm 	100-40-160 (pcs)	9	150	40			1127	3.31.100.40.160
	100-40-160 (set)				8xW+8xJ		1543	3.31.100.40.160.ST
	100-40-160 (M5)					M5	1127	3.31.100.40.160.M5
	100-40-160 (M5 set)				8xW+8xJ+1xP	M5	1545	3.31.100.40.160.M5.ST
PG45 180mm 	100-45-180 (pcs)	9	170	45			1293	3.31.100.45.180
	100-45-180 (set)				8xW+8xJ		1709	3.31.100.45.180.ST
	100-45-180 (M5)					M5	1293	3.31.100.45.180.M5
	100-45-180 (M5 set)				8xW+8xJ+1xP	M5	1711	3.31.100.45.180.M5.ST

Connecting Elements

Angle Profile Bracket

Material: aluminium, anodized



100x100x15

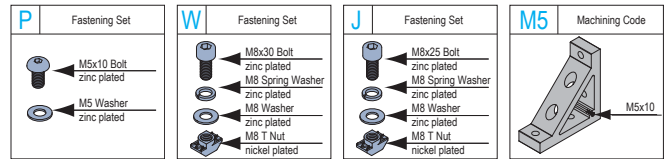
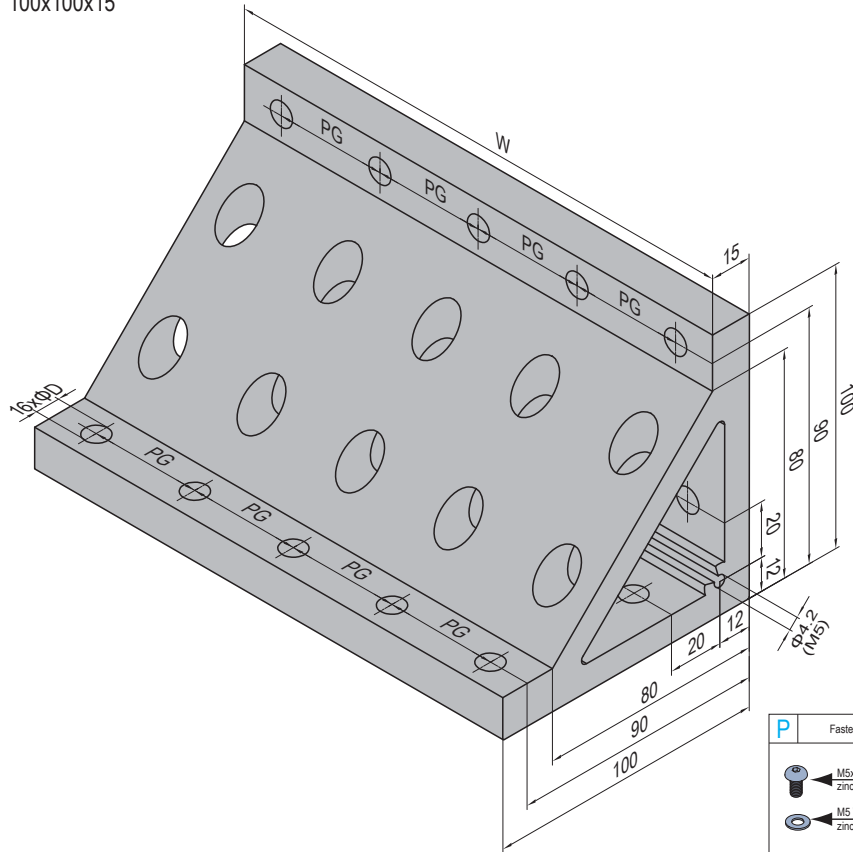

Application	Description	D (mm)	W (mm)	PG (mm)	Fastening Set	Machining Code	Mass (g)	Part No.
PG40 200mm 	100-40-200 (pcs)	9	190	40			1477	3.31.100.40.200
	100-40-200 (set)				10xW+10xJ		1893	3.31.100.40.200.ST
	100-40-200 (M5)					M5	1477	3.31.100.40.200.M5
	100-40-200 (M5 set)				10xW+10xJ+1xP	M5	1895	3.31.100.40.200.M5.ST



Connecting Elements

Inner Bracket (with top thread)

Inner bracket is with low cost and high efficiency, widely used for the assembly of door, window and protection frame.

Material: bracket-diecast zinc top thread-zinc plated steel

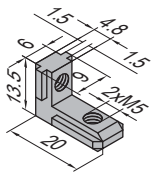

- M5x6
- Inner Bracket-6-A 3.41.06A
- Inner Bracket-6-B 3.41.06B

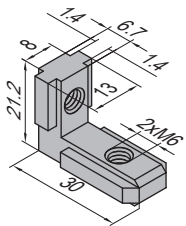

- M6x8
- Inner Bracket-8-A 3.41.08A
- Inner Bracket-8-B 3.41.08B

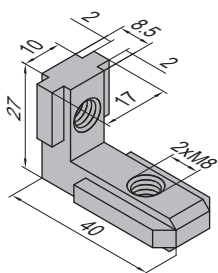

- M8x10
- Inner Bracket-10-A 3.41.10A
- Inner Bracket-10-B 3.41.10B

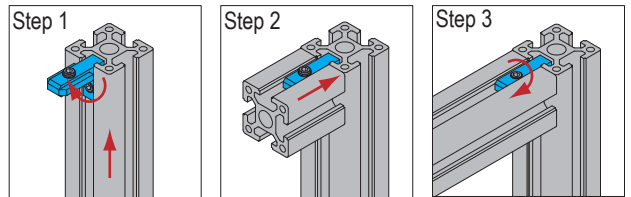
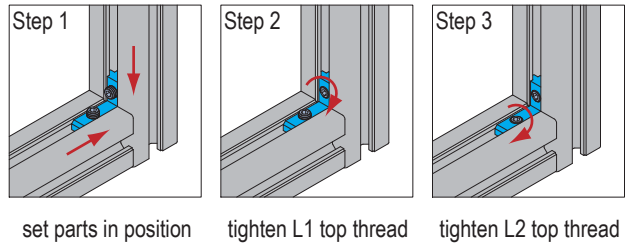
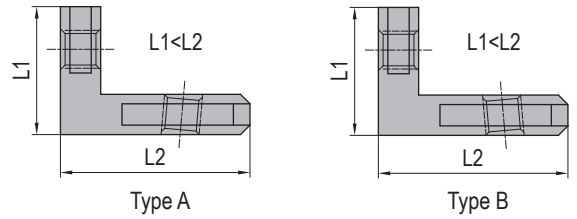
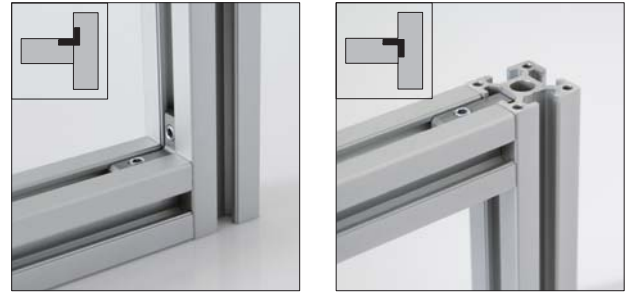

Description	Mass (g/pcs)	Part No.
Inner Bracket-6-A (with top thread)	6	3.41.06A
Inner Bracket-6-B (with top thread)		3.41.06B
Inner Bracket-8-A (with top thread)	18	3.41.08A
Inner Bracket-8-B (with top thread)		3.41.08B
Inner Bracket-10-A (with top thread)	36	3.41.10A
Inner Bracket-10-B (with top thread)		3.41.10B



Connecting Elements

Linear Bar Connector (with top thread)
Material: zinc plated steel

Linear Bar Connector-6

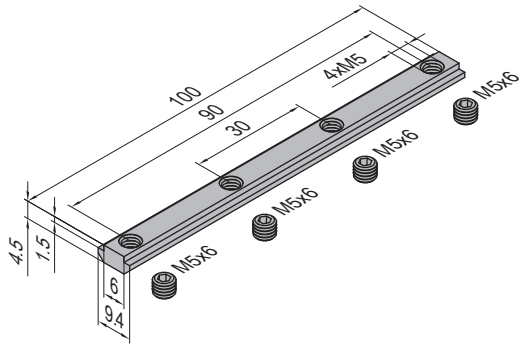

Linear Bar Connector-8

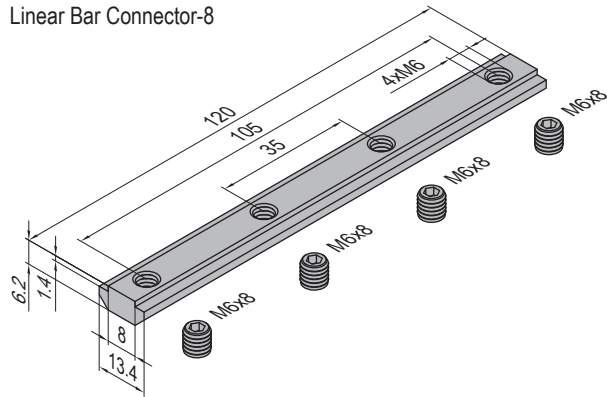

Linear Bar Connector-10

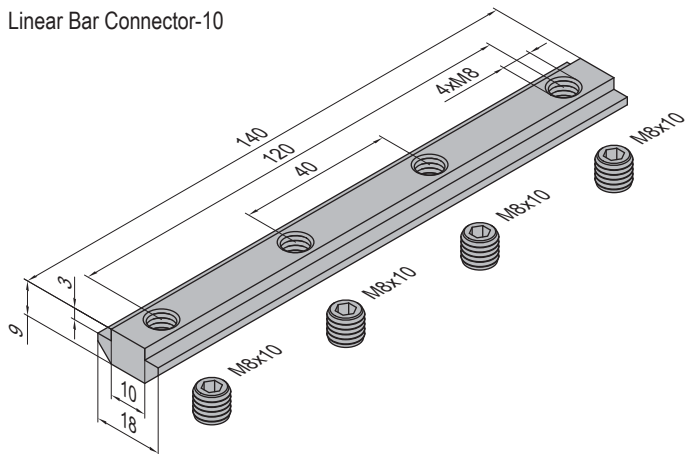

Description	Mass (g/pcs)	Part No.
Linear Bar Connector-6 (with top thread)	27	3.51.06
Linear Bar Connector-8 (with top thread)	65	3.51.08
Linear Bar Connector-10 (with top thread)	132	3.51.10



Connecting Elements

Linear Bar Connector (with top thread)

Material: zinc plated steel

Linear Bar Connector-8

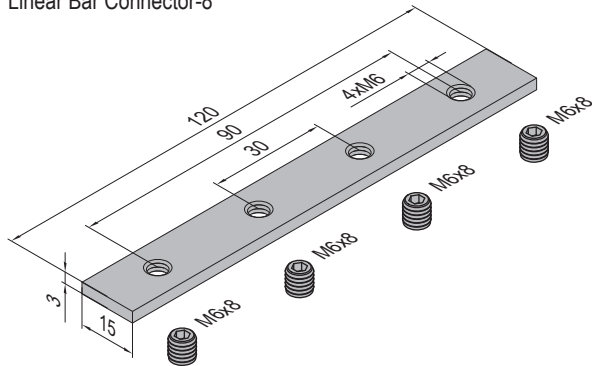

Description	Mass (g/pcs)	Part No.
Linear Bar Connector-8 (with top thread)	40	3.52.08
Linear Bar Connector-10 (with top thread)	74	3.52.10

Linear Bar Connector-10

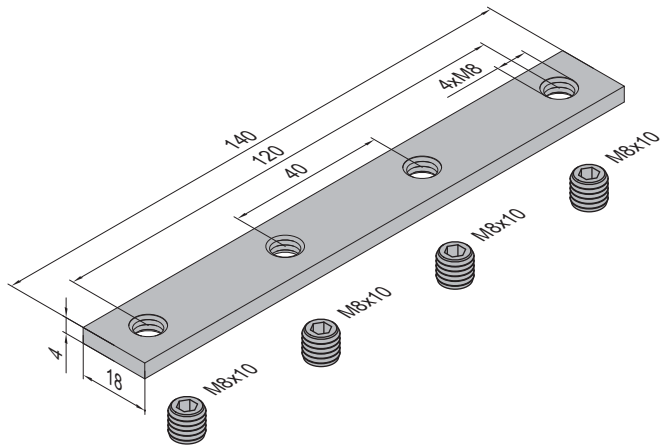

Connecting Elements

Joining Plate

Material: zinc plated steel



PG30-3030-01

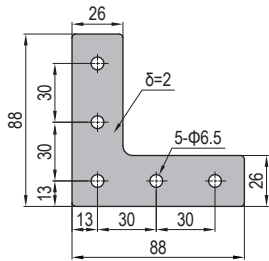

PG30-3030-02

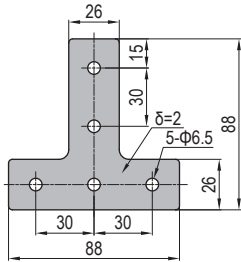

PG30-3030-03

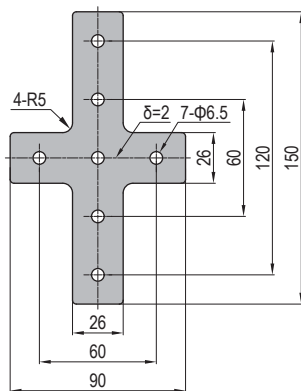

PG	Fastening Set	PH	Fastening Set
	M6x10 Bolt zinc plated		M6x10 Bolt zinc plated
	M6 Spring Washer zinc plated		M6 Spring Washer zinc plated
	M6 T Nut nickel plated		M6 Pre-set Nut nickel plated

Description	Fastening Set	Mass (g)	Part No.
PG30-3030-01 (pcs)		58	3.53.30.3030.01
PG30-3030-01 (set A)	5xPG	92	3.53.30.3030.01.STA
PG30-3030-01 (set B)	5xPH	112	3.53.30.3030.01.STB
PG30-3030-02 (pcs)		58	3.53.30.3030.02
PG30-3030-02 (set A)	5xPG	92	3.53.30.3030.02.STA
PG30-3030-02 (set B)	5xPH	112	3.53.30.3030.02.STB
PG30-3030-03 (pcs)		83	3.53.30.3030.03
PG30-3030-03 (set A)	7xPG	130	3.53.30.3030.03.STA
PG30-3030-03 (set B)	7xPH	158	3.53.30.3030.03.STB



Connecting Elements

Joining Plate

Material: zinc plated steel



PG40-4040-01

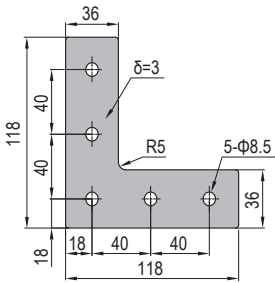



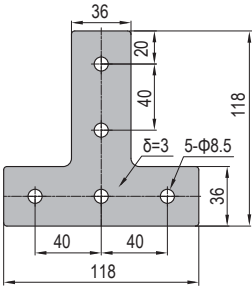

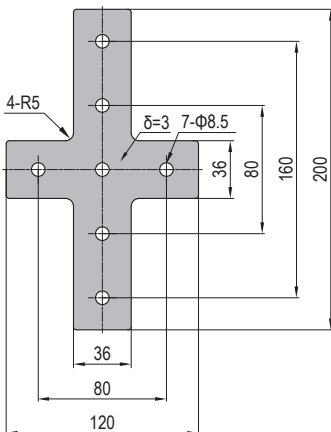

PG40-4040-02



PG40-4040-03



X	Fastening Set	Y	Fastening Set
	M8x12 Bolt zinc plated		M8x12 Bolt zinc plated
	M8 Spring Washer zinc plated		M8 Spring Washer zinc plated
	M8 T Nut nickel plated		M8 Pre-set Nut nickel plated

Description	Fastening Set	Mass (g)	Part No.
PG40-4040-01 (pcs)		147	3.53.40.4040.01
PG40-4040-01 (set X)	5xX	217	3.53.40.4040.01.STX
PG40-4040-01 (set Y)	5xY	257	3.53.40.4040.01.STY
PG40-4040-02 (pcs)		149	3.53.40.4040.02
PG40-4040-02 (set X)	5xX	219	3.53.40.4040.02.STX
PG40-4040-02 (set Y)	5xY	259	3.53.40.4040.02.STY
PG40-4040-03 (pcs)		230	3.53.40.4040.03
PG40-4040-03 (set X)	7xX	328	3.53.40.4040.03.STX
PG40-4040-03 (set Y)	7xY	384	3.53.40.4040.03.STY

Connecting Elements

Joining Plate

Material: zinc plated steel



PG40-4040-04

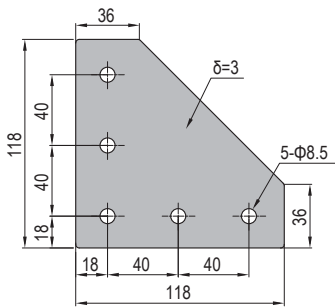



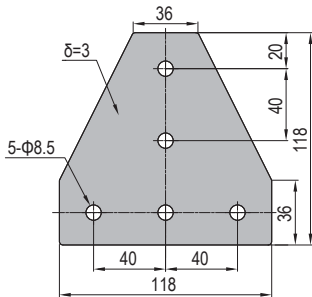

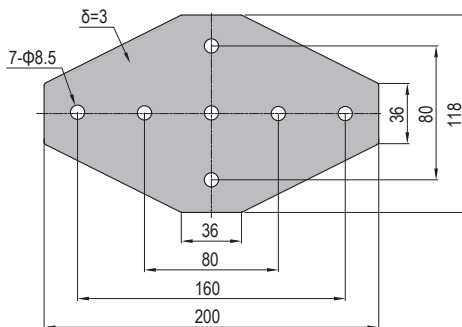

PG40-4040-05



PG40-4040-06



X	Fastening Set	Y	Fastening Set
	M8x12 Bolt zinc plated		M8x12 Bolt zinc plated
	M8 Spring Washer zinc plated		M8 Spring Washer zinc plated
	M8 T Nut nickel plated		M8 Pre-set Nut nickel plated

Description	Fastening Set	Mass (g)	Part No.
PG40-4040-04 (pcs)		222	3.53.40.4040.04
PG40-4040-04 (set X)	5xX	292	3.53.40.4040.04.STX
PG40-4040-04 (set Y)	5xY	332	3.53.40.4040.04.STY
PG40-4040-05 (pcs)		220	3.53.40.4040.05
PG40-4040-05 (set X)	5xX	290	3.53.40.4040.05.STX
PG40-4040-05 (set Y)	5xY	330	3.53.40.4040.05.STY
PG40-4040-06 (pcs)		355	3.53.40.4040.06
PG40-4040-06 (set X)	7xX	453	3.53.40.4040.06.STX
PG40-4040-06 (set Y)	7xY	510	3.53.40.4040.06.STY

Connecting Elements

Joining Plate

Material: zinc plated steel



PG40-4080-01

PG40-4080-02

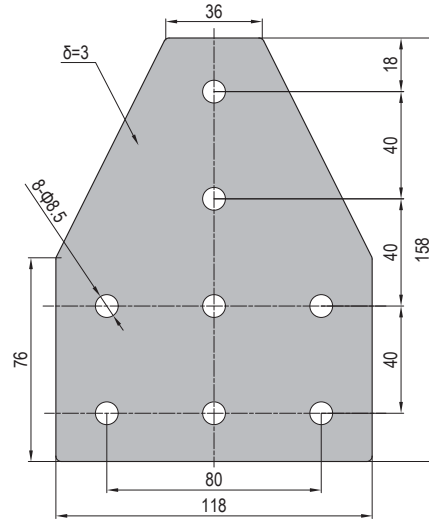
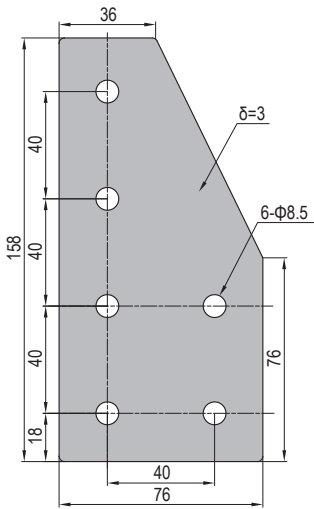

PG40-4080-03

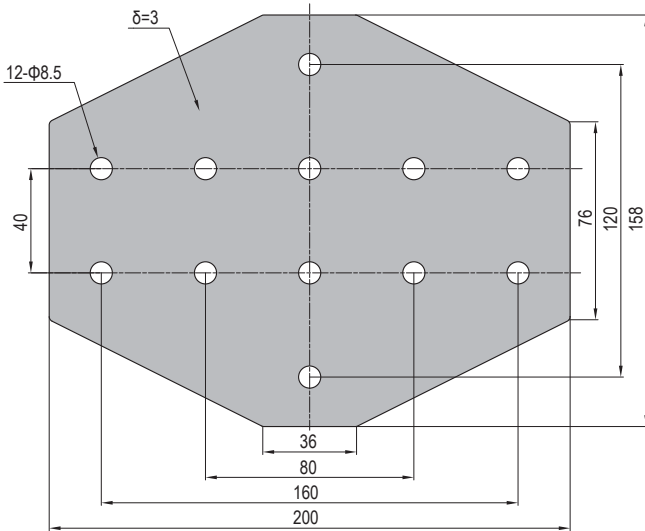

X	Fastening Set	Y	Fastening Set
	M8x12 Bolt zinc plated		M8x12 Bolt zinc plated
	M8 Spring Washer zinc plated		M8 Spring Washer zinc plated
	M8 T Nut nickel plated		M8 Pre-set Nut nickel plated

Description	Fastening Set	Mass (g)	Part No.
PG40-4080-01 (pcs)		222	3.53.40.4080.01
PG40-4080-01 (set X)	6xX	306	3.53.40.4080.01.STX
PG40-4080-01 (set Y)	6xY	354	3.53.40.4080.01.STY
PG40-4080-02 (pcs)		347	3.53.40.4080.02
PG40-4080-02 (set X)	8xX	459	3.53.40.4080.02.STX
PG40-4080-02 (set Y)	8xY	523	3.53.40.4080.02.STY
PG40-4080-03 (pcs)		523	3.53.40.4080.03
PG40-4080-03 (set X)	12xX	691	3.53.40.4080.03.STX
PG40-4080-03 (set Y)	12xY	787	3.53.40.4080.03.STY



Connecting Elements

Joining Plate

Material: zinc plated steel



PG40-8080-01

PG40-8080-02

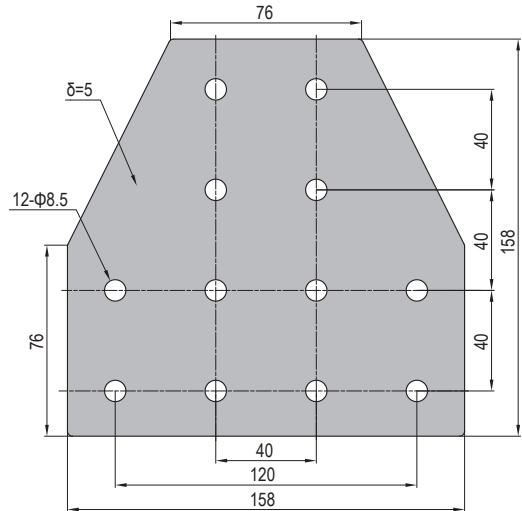
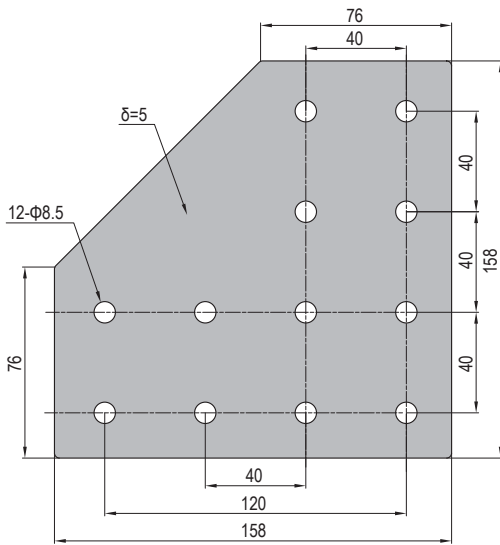

PG40-8080-03

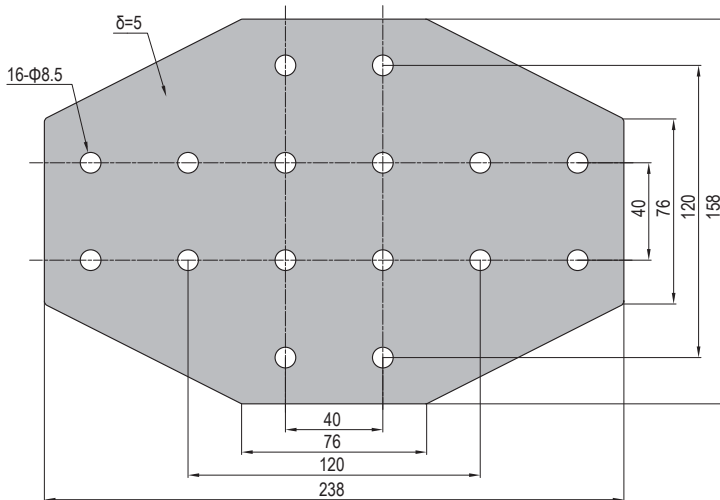

I	Fastening Set	O	Fastening Set
	M8x16 Bolt zinc plated		M8x16 Bolt zinc plated
	M8 Spring Washer zinc plated		M8 Spring Washer zinc plated
	M8T Nut nickel plated		M8 Pre-set Nut nickel plated

Description	Fastening Set	Mass (g)	Part No.
PG40-8080-01 (pcs)		730	3.53.40.8080.01
PG40-8080-01 (set I)	12xI	910	3.53.40.8080.01.STI
PG40-8080-01 (set O)	12xO	1006	3.53.40.8080.01.STO
PG40-8080-02 (pcs)		731	3.53.40.8080.02
PG40-8080-02 (set I)	12xI	911	3.53.40.8080.02.STI
PG40-8080-02 (set O)	12xO	1007	3.53.40.8080.02.STO
PG40-8080-03 (pcs)		1043	3.53.40.8080.03
PG40-8080-03 (set I)	16xI	1283	3.53.40.8080.03.STI
PG40-8080-03 (set O)	16xO	1411	3.53.40.8080.03.STO



Connecting Elements

Joining Plate

Material: zinc plated steel



PG45-4545-01

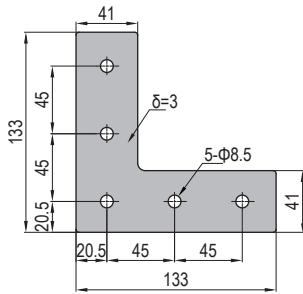

PG45-4545-02

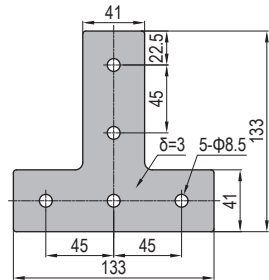

PG45-4545-03

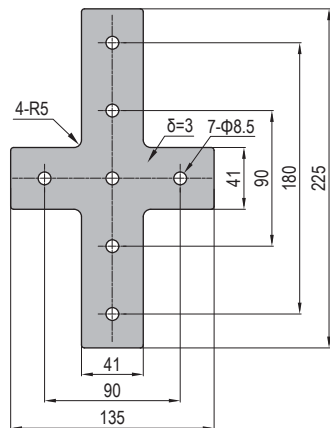

I	Fastening Set	O	Fastening Set
	M8x16 Bolt zinc plated		M8x16 Bolt zinc plated
	M8 Spring Washer zinc plated		M8 Spring Washer zinc plated
	M8T Nut nickel plated		M8 Pre-set Nut nickel plated

Description	Fastening Set	Mass (g)	Part No.
PG45-4545-01 (pcs)		209	3.53.45.4545.01
PG45-4545-01 (set I)	5xI	288	3.53.45.4545.01.STI
PG45-4545-01 (set O)	5xO	328	3.53.45.4545.01.STO
PG45-4545-02 (pcs)		209	3.53.45.4545.02
PG45-4545-02 (set I)	5xI	288	3.53.45.4545.02.STI
PG45-4545-02 (set O)	5xO	328	3.53.45.4545.02.STO
PG45-4545-03 (pcs)		297	3.53.45.4545.03
PG45-4545-03 (set I)	7xI	408	3.53.45.4545.03.STI
PG45-4545-03 (set O)	7xO	464	3.53.45.4545.03.STO

Connecting Elements

Butt Connector



Butt Connector is used for profile affiliating connection and widely used in clean room.

Material: zinc alloy, nickel plated

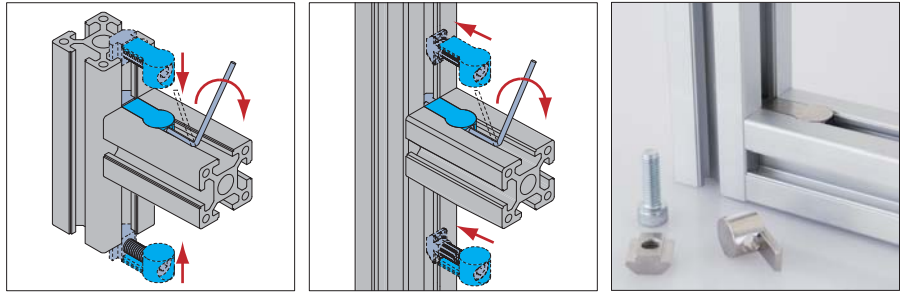

Butt Connector-8

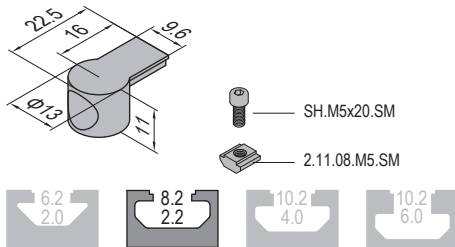

Butt Connector-10

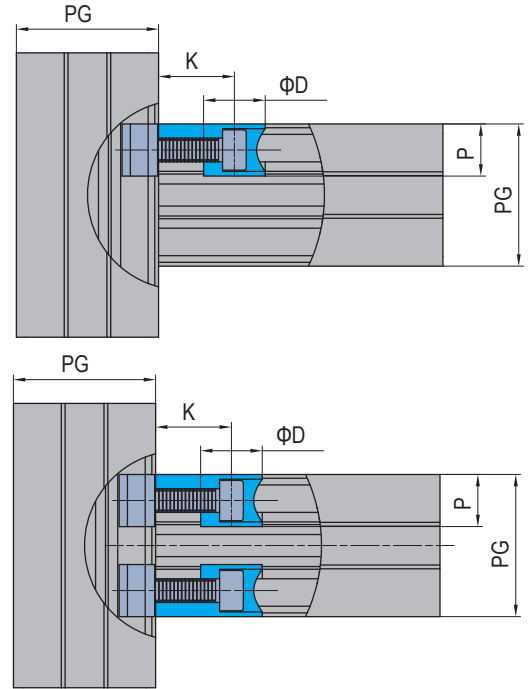
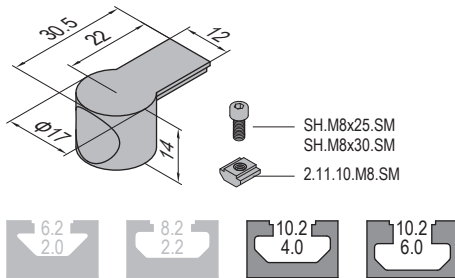

PG	Fastening Set	CD	Fastening Set	CE	Fastening Set	Q	Fastening Set	T	Fastening Set	S	Fastening Set
	M5x20 Bolt zinc plated M5 T Nut nickel plated		M8x25 Bolt zinc plated M8 T Nut nickel plated		M8x30 Bolt zinc plated M8 T Nut nickel plated		M5x20 Bolt zinc plated M5 Pre-set Nut nickel plated		M8x25 Bolt zinc plated M8 Pre-set Nut nickel plated		M8x30 Bolt zinc plated M8 Pre-set Nut nickel plated

Description	PG	K (mm)	D (mm)	P (mm)	Fastening Set	Mass (g)	Part No.
Butt Connector-8 (pcs)						9	3.61.08
Butt Connector-8 (set A)	PG30	16	13	11	1xQ	20	3.61.08.STA
Butt Connector-8 (set B)					1xPG	18	3.61.08.STB
Butt Connector-10 (pcs)	PG40/PG45/PG50/PG60					15	3.61.10
Butt Connector-10-4 (set A)	PG40				1xT	41	3.61.10.04.STA
Butt Connector-10-4 (set B)		22	17	14	1xCD	37	3.61.10.04.STB
Butt Connector-10-6 (set A)					1xS	43	3.61.10.06.STA
Butt Connector-10-6 (set B)	PG45/PG50/PG60				1xCE	39	3.61.10.06.STB



Connecting Elements

End Connector

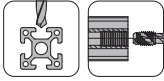

End connector is also called butterfly button connector due to its shape which can hide itself completely in aluminum profile, so it is widely used for frame structures in clean room.

Material: nickel plated steel



End Connector-8

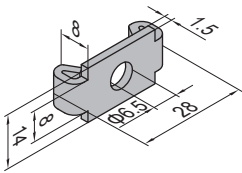

End Connector-10

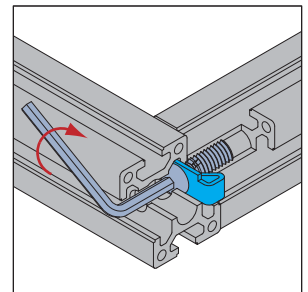
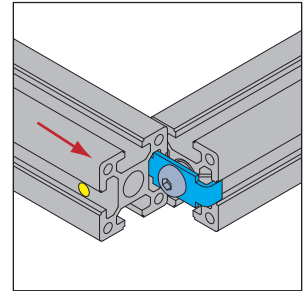
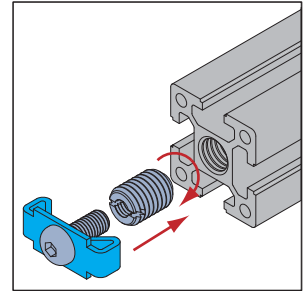
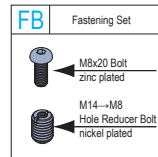
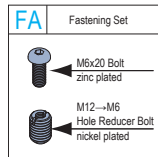
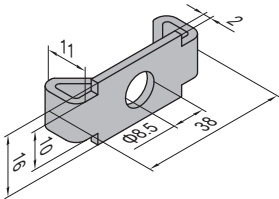

Description	PG	Fastening Set	Mass (g)	Part No.
End Connector-8 (pcs)	PG30		7	3.71.30
End Connector-8 (set)		1xFA	23	3.71.30.ST
End Connector-10 (pcs)	PG40		13	3.71.40
End Connector-10 (set)		1xFB	38	3.71.40.ST

Connecting Elements



A simple and economic way to replace end connector with more connection reliability.

Material: nickel plated steel



Screw Connector-6

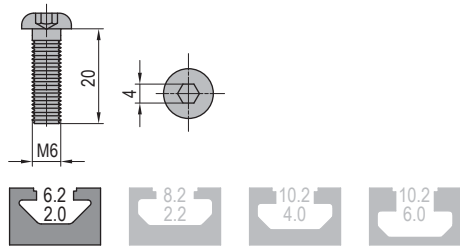

Screw Connector-8

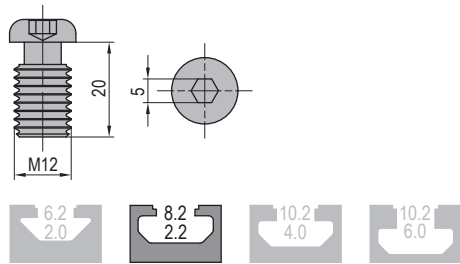

Screw Connector-10

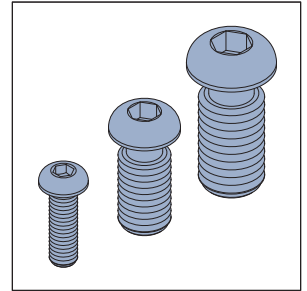
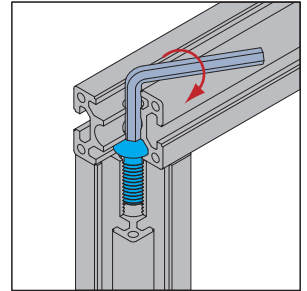
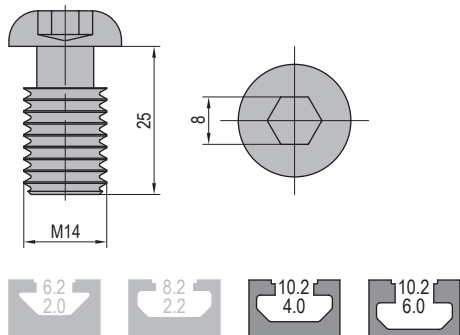

Description	Mass (g)	Part No.
Screw Connector-6	7	3.81.06
Screw Connector-8	17	3.81.08
Screw Connector-10	31	3.81.10

Connecting Elements

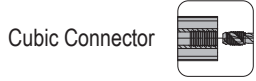

Material: Connector-diecast aluminum Cap-black ABS



Cubic Connector-4545-2

Cubic Connector-4545-3

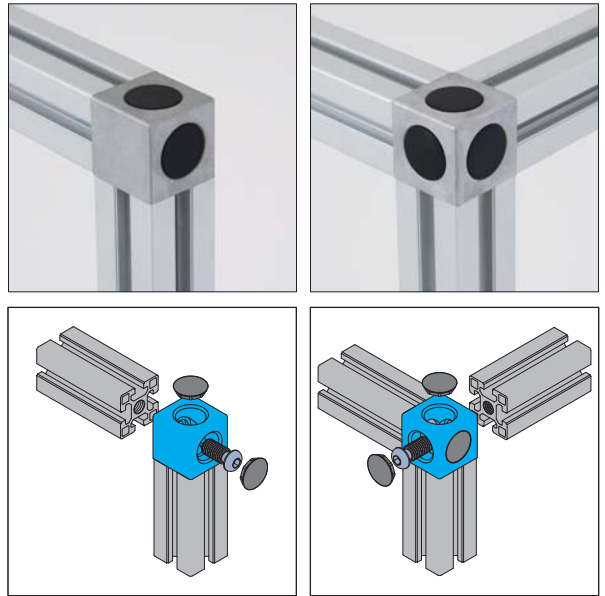
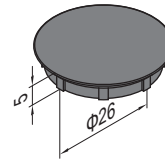
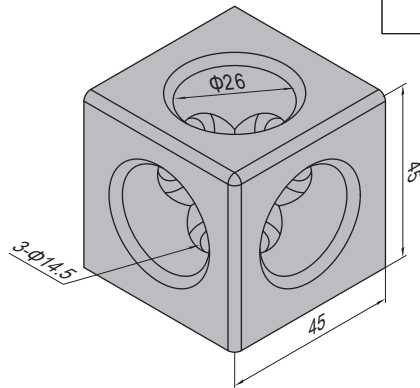
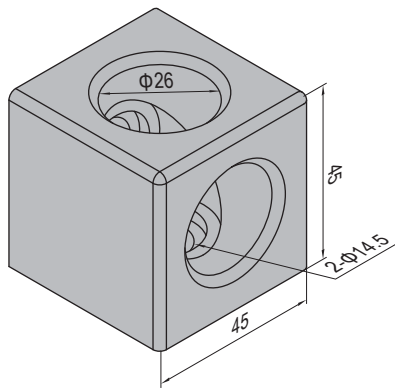

Description	Fastening Set	Cap (pcs)	Mass (g)	Part No.
Cubic Connector-4545-2 (pcs)		2	135	3.91.4545.02
Cubic Connector-4545-2 (set)	2x(M14x25)		201	3.91.4545.02.ST
Cubic Connector-4545-3 (pcs)		3	135	3.91.4545.03
Cubic Connector-4545-3 (set)	3x(M14x25)		234	3.91.4545.03.ST

Connecting Elements

Cubic Connector



Material: Connector-diecast zinc Cap-black ABS

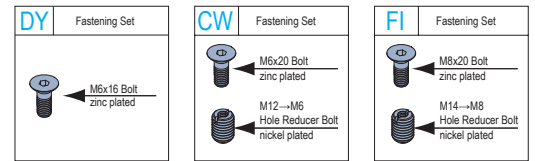
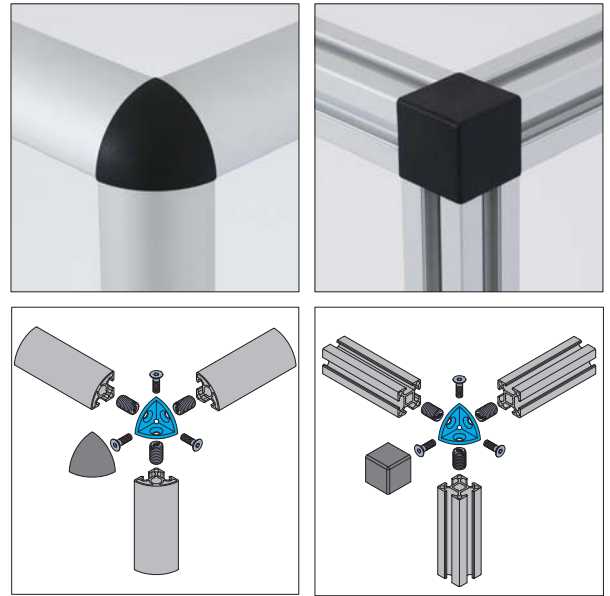
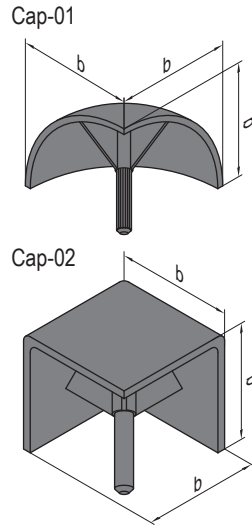
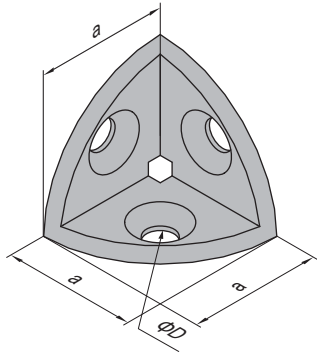
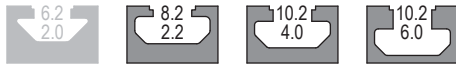

Description	a	b	D	Fastening Set	Cap (pcs)	Mass (g)	Part No.
2020-01 (pcs)	18.5	20	6.5	3xDY	1	11	3.92.2020.01
2020-01 (set)						23	3.92.2020.01.ST
2020-02 (pcs)						12	3.92.2020.02
2020-02 (set)						24	3.92.2020.02.ST
3030-01 (pcs)	28	30	6.5	3xCW	1	35	3.92.3030.01
3030-01 (set)						105	3.92.3030.01.ST
3030-02 (pcs)						38	3.92.3030.02
3030-02 (set)						108	3.92.3030.02.ST
4040-01 (pcs)	38	40	8.5	3xFI	1	87	3.92.4040.01
4040-01 (set)						159	3.92.4040.01.ST
4040-02 (pcs)						92	3.92.4040.02
4040-02 (set)						164	3.92.4040.02.ST
4545-01 (pcs)	42	45	8.5	3xFI	1	114	3.92.4545.01
4545-01 (set)						187	3.92.4545.01.ST
4545-02 (pcs)						123	3.92.4545.02
4545-02 (set)						196	3.92.4545.02.ST





4.11-4.21

End Cap

T Slot Cover

4

Profile Accessories



P. 4-02



P. 4-04



Profile Accessories

End Cap

To prevent staff from any injury and improve profile end appearance.

Material and Color: black ABS

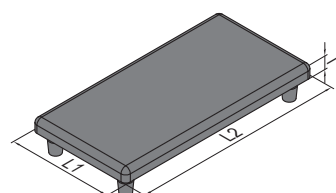

Description	L1 (mm)	L2 (mm)	T (mm)	Mass (g)	Part No.
End Cap-PG15-1515	15	15	3	1	4.11.15.1515
End Cap-PG15-1530	15	30	3	1.1	4.11.15.1530
End Cap-PG20-2020	20	20	4	2	4.11.20.2020
End Cap-PG20-2040	20	40	4	3	4.11.20.2040
End Cap-PG20-2060	20	60	4	4	4.11.20.2060
End Cap-PG20-2080	20	80	4	5	4.11.20.2080
End Cap-PG20-4040	40	40	4	6	4.11.20.4040
End Cap-PG30-3030	30	30	5	3	4.11.30.3030
End Cap-PG30-3060	30	60	5	8	4.11.30.3060
End Cap-PG30-3090	30	90	5	11	4.11.30.3090
End Cap-PG30-30120	30	120	5	14	4.11.30.30120
End Cap-PG30-6060	60	60	5	15	4.11.30.6060
End Cap-PG30-60120	60	120	5	33	4.11.30.60120
End Cap-PG40-4040	40	40	5	6	4.11.40.4040
End Cap-PG40-4060	40	60	5	9	4.11.40.4060
End Cap-PG40-4080	40	80	5	13	4.11.40.4080
End Cap-PG40-40120	40	120	5	18	4.11.40.40120
End Cap-PG40-40160	40	160	5	24	4.11.40.40160
End Cap-PG40-8080	80	80	5	22	4.11.40.8080
End Cap-PG40-80120	80	120	5	43	4.11.40.80120
End Cap-PG40-80160	80	160	5	58	4.11.40.80160
End Cap-PG40-80200	80	200	5	72	4.11.40.80200
End Cap-PG40-120120	120	120	5	64	4.11.40.120120
End Cap-PG45-4545	45	45	5	8	4.11.45.4545
End Cap-PG45-4560	45	60	5	11	4.11.45.4560
End Cap-PG45-4590	45	90	5	16	4.11.45.4590
End Cap-PG45-9090	90	90	5	28	4.11.45.9090
End Cap-PG45-90180	90	180	5	72	4.11.45.90180
End Cap-PG50-5050	50	50	5	10	4.11.50.5050
End Cap-PG50-50100	50	100	5	18	4.11.50.50100
End Cap-PG50-100100	100	100	5	44	4.11.50.100100
End Cap-PG60-6060	60	60	5	14	4.11.60.6060



Profile Accessories

End Cap

To prevent staff from any injury and improve profile end appearance.

Material and Color: black ABS

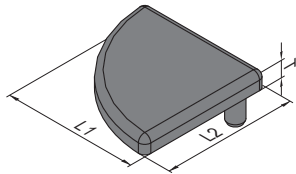

Description	L1 (mm)	L2 (mm)	T (mm)	Mass (g)	Part No.
End Cap-PG20-2020R	20	20	4	1	4.11.20.2020R
End Cap-PG30-3030R	30	30	5	3	4.11.30.3030R
End Cap-PG40-4040R	40	40	5	6	4.11.40.4040R
End Cap-PG45-4545R	45	45	5	7	4.11.45.4545R

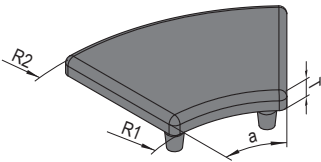

Description	R1 (mm)	R2 (mm)	α	T (mm)	Mass (g)	Part No.
End Cap-PG30-3030R45	30	60	45°	5	4	4.11.30.3030R45 New
End Cap-PG40-4040R45	40	80	45°	5	7	4.11.40.4040R45 New
End Cap-PG45-4545R45	45	90	45°	5	9	4.11.45.4545R45 New

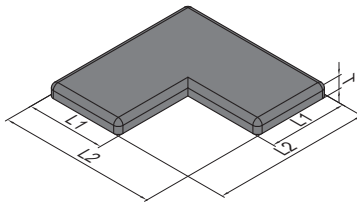

Description	L1 (mm)	L2 (mm)	T (mm)	Mass (g)	Part No.
End Cap-PG30-6060L	30	60	5	11	4.11.30.6060L
End Cap-PG40-8080L	40	80	5	17	4.11.40.8080L
End Cap-PG45-9090L	45	90	5	22	4.11.45.9090L

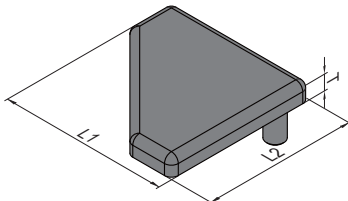

Description	L1 (mm)	L2 (mm)	T (mm)	Mass (g)	Part No.
End Cap-PG40-4040T	40	40	5	5.3	4.11.40.4040T

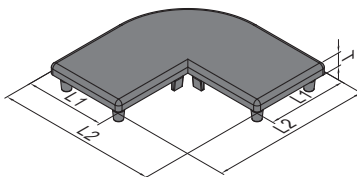

Description	L1 (mm)	L2 (mm)	T (mm)	Mass (g)	Part No.
End Cap-PG40-8080R	40	80	5	17	4.11.40.8080R New



Profile Accessories

Conduit end cap

To prevent staff from any injury and improve profile end appearance.

Material: stainless steel



Conduit Cap-40x40

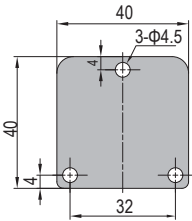

Conduit Cap-40x80

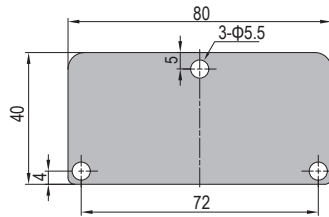

Conduit Cap-60x120

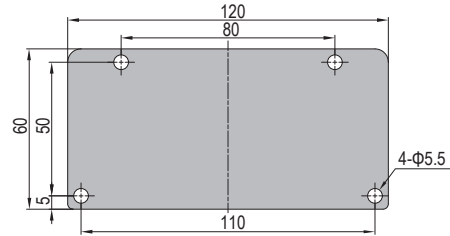

Conduit Cap-80x80

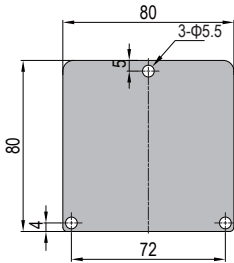

Conduit Cap-80x160

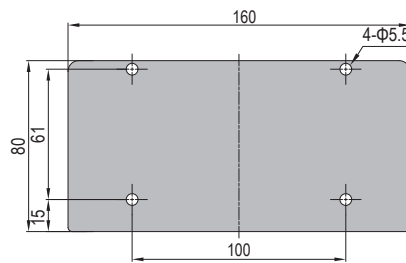

Conduit Cap-80x200

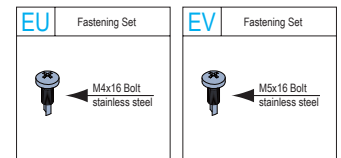
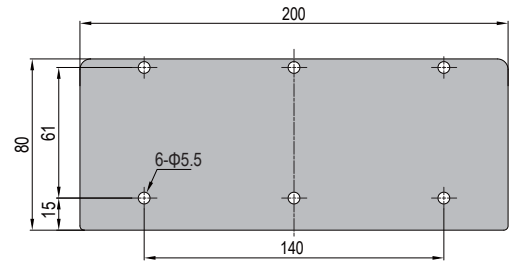

Description	Thickness T(mm)	Fastening Set	Mass (g)	Part No.
Conduit Cap-40x40(pcs)	2		24.5	4.14.40.4040
Conduit Cap-40x40(set)		3xEU	29	4.14.40.4040.ST
Conduit Cap-40x80(pcs)			50	4.14.40.4080
Conduit Cap-40x80(set)		3xEV	59	4.14.40.4080.ST
Conduit Cap-60x120(pcs)/			113	4.14.40.60120
Conduit Cap-60x120(set)		4xEV	125	4.14.40.60120.ST
Conduit Cap-80x80(pcs)			99	4.14.40.8080
Conduit Cap-80x80(set)		3xEV	108	4.14.40.8080.ST
Conduit Cap-80x160(pcs)			203	4.14.40.80160
Conduit Cap-80x160(set)		4xEV	215	4.14.40.80160.ST
Conduit Cap-80x200(pcs)			247	4.14.40.80200
Conduit Cap-80x200(set)		6xEV	265	4.14.40.80200.ST



Profile Accessories

T Slot Cover

To prevent slot from contamination and improve structure appearance.

Material and Color: PP black/blue/grey/orange



T Slot Cover-6

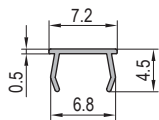

T Slot Cover-8

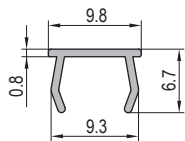

T Slot Cover-10

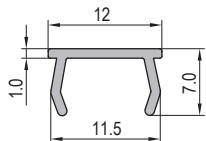

Description	Color	Mass (g/m)	Delivery Length	Part No.
T Slot Cover-6	Black	11	2000mm/bar	4.21.06.BK
T Slot Cover-6	Blue			4.21.06.BE
T Slot Cover-6	Grey			4.21.06.GY
T Slot Cover-6	Orange			4.21.06.SE
T Slot Cover-8	Black	22		4.21.08.BK
T Slot Cover-8	Blue			4.21.08.BE
T Slot Cover-8	Grey			4.21.08.GY
T Slot Cover-8	Orange			4.21.08.SE
T Slot Cover-10	Black	38		4.21.10.BK
T Slot Cover-10	Blue			4.21.10.BE
T Slot Cover-10	Grey		4.21.10.GY	
T Slot Cover-10	Orange		4.21.10.SE	

Note:

1. Cut to delivery length is not available, but 4000mm or Max. 5800 delivery length is available upon request.
2. Customized color upon request is subject to 5000 meters minimum order quantities.



5.11-5.61

Base Plate

Base Plate

Leveling Foot

Mounting Plate

Castor Plate

Castor

Base Angle

L Base

Foot and Castor
Components

Leveling Castor

5

Floor Elements



P. 5-02



P. 5-03

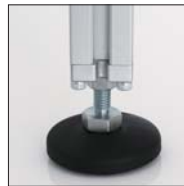

P. 5-04



P. 5-07



P. 5-08



P. 5-10



P. 5-11



P. 5-14



P. 5-15



P. 5-16



P. 5-17



P. 5-18

Floor Elements

Base Plate

To support strut profile at the bottom. Expansion bolts chocked into floor can offer a high stability.

Material and surface treatment: cast steel, black electrophoresis

Base Plate Gasket



To adjust the degree of vertical profile and uneven ground.

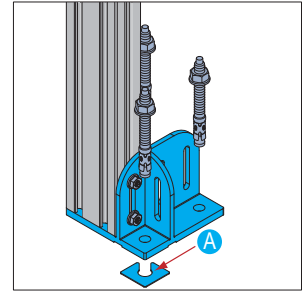
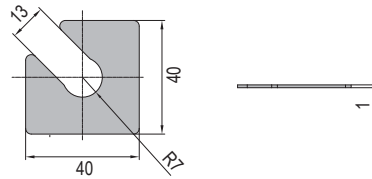

Base Plate-4080

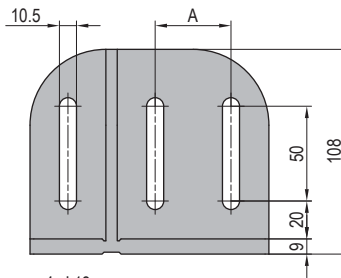
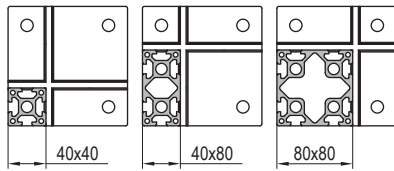
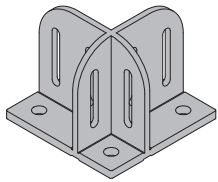

Base Plate-4560

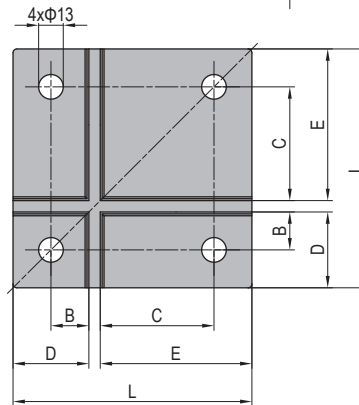
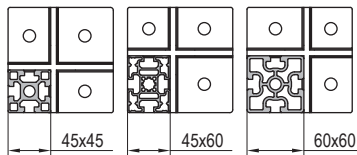
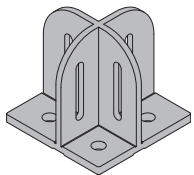

Base Plate-4590

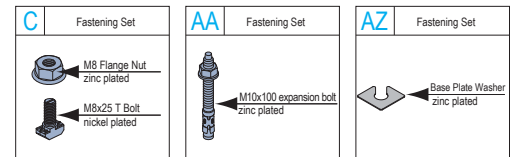
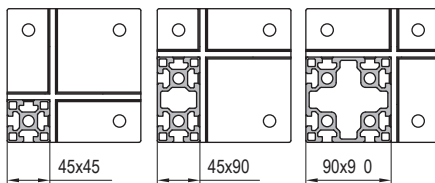
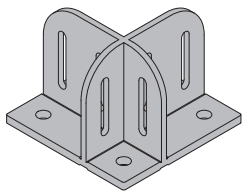

Description	L (mm)	A (mm)	B (mm)	C (mm)	D (mm)	E (mm)	Fastening Set	Mass (g)	Part No.
Base Plate-4080 (pcs)	126	40	20	60	40	80	2xAZ	1930	5.11.4080
Base Plate-4080 (set A)							4xC+3xAA+2xAZ	2240	5.11.4080.STA
Base Plate-4080 (set B)							6xC+3xAA+2xAZ	2290	5.11.4080.STB
Base Plate-4080 (set C)							8xC+3xAA+2xAZ	2340	5.11.4080.STC
Base Plate-4560 (pcs)	111		22.5	30	45	60	2xAZ	1600	5.11.4560
Base Plate-4560 (set)							4xC+3xAA+2xAZ	1910	5.11.4560.ST
Base Plate-4590 (pcs)	141	45	22.5	67.5	45	90	2xAZ	2330	5.11.4590
Base Plate-4590 (set A)							4xC+3xAA+2xAZ	2640	5.11.4590.STA
Base Plate-4590 (set B)							6xC+3xAA+2xAZ	2690	5.11.4590.STB
Base Plate-4590 (set C)							8xC+3xAA+2xAZ	2740	5.11.4590.STC
Base Plate Gasket 								9	5.11.01

Floor Elements

Base Plate

To support strut profile mounted on the floor or between the platforms. Expansion bolts chocked into the floor can offer a high stability.

Material: diecast-aluminum



Base Plate-4080

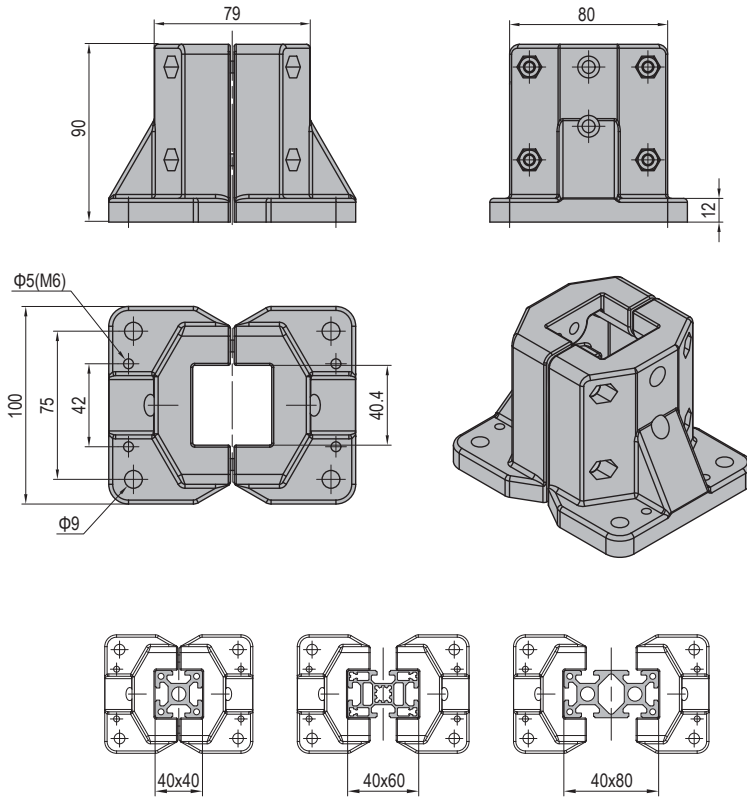

Description	Fastening Set	Mass	Part No.
Base Plate-4080 (set)	4xDT	975	5.12.40.ST

DT	Fastening Set
	M6x20 Bolt zinc plated
	M6 Spring Washer zinc plated
	M6 Pre-set Nut nickel plated



Floor Elements

Leveling Foot-Pivot Foot



To support structure where gradual height adjustment is needed, the pivot foot has a small swiveling angle to fit slightly uneven floor. The connection between the pivot base and the spindle can be released with a tool.

Material and Color: Base-black PA6 Spindle-zinc plated steel Pad-black rubber



Pivot Foot

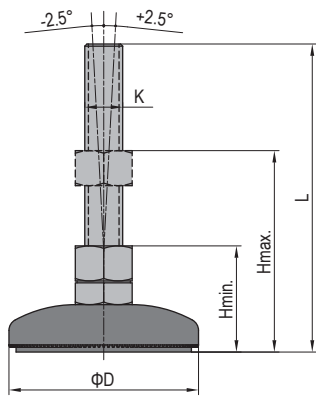

Description	D (mm)	KxL (mm)	H min. (mm)	H max. (mm)	Max. Static Load (N)	Mass (g)	Part No.
Pivot Foot-PA 6 Base	59	M12x90	45	70	4500	152	5.21.60.12.90
		M14x130		100	7000	220	5.21.60.14.130
	79	M12x90	45	70	9000	188	5.21.80.12.90
		M12x130		100		218	5.21.80.12.130
		M16x130		100		328	5.21.80.16.130
	99	M12x130	45	100	10000	326	5.21.100.12.130
M16x130		100		436		5.21.100.16.130	

Leveling Foot-Swivel Foot



To support structure where gradual height adjustment is needed, the swivel foot has a ball joint between the base and spindle, thus allowing the foot to swivel to an angle up to 30°. It is suitable to be used on the components moved frequently.

Material and Color: Base-black PA6 Spindle-zinc plated steel Pad-black rubber



Swivel Foot

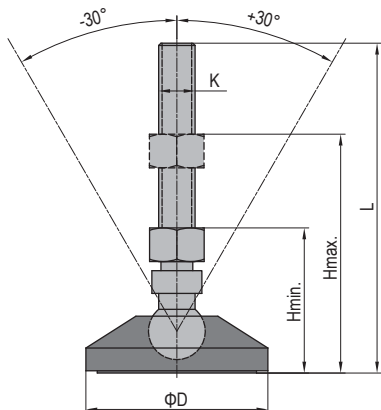

Description	D (mm)	KxL (mm)	H min. (mm)	H max. (mm)	Max. Static Load (N)	Mass (g)	Part No.
Swivel Foot-PA 6 Base	59	M12x90	45	70	4500	162	5.22.60.12.90
		M12x90		70	9000	198	5.22.80.12.90
	79	M12x130	45	100		228	5.22.80.12.130
		M16x130		100		338	5.22.80.16.130
	99	M12x130	45	100	10000	336	5.22.100.12.130
		M16x130		100		446	5.22.100.16.130

Floor Elements

Leveling Foot-Swivel Foot with holes



New!

To support structure where gradual height adjustment is needed, the swivel foot has a ball joint between the base and spindle, thus allowing the foot to swivel to an angle up to 30°. It is suitable for uneven surface and fixed with expansion bolts.

Material and Color: Base-black PA6 Spindle-zinc plated steel Pad-black rubber

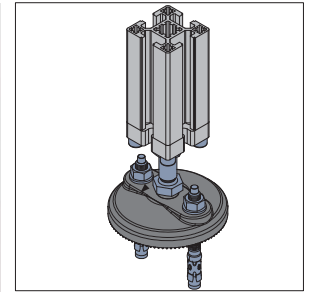
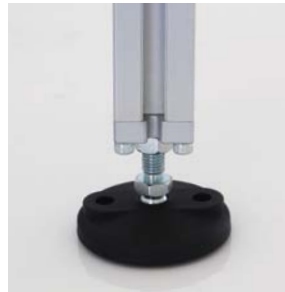

Swivel Foot with holes

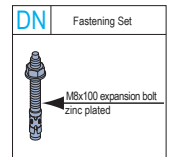
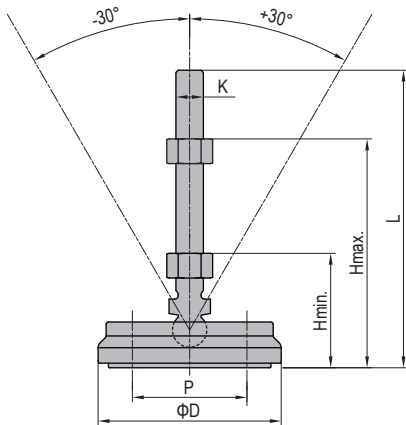

Description	D (mm)	P (mm)	KxL (mm)	H min. (mm)	H max. (mm)	Max. Static Load (N)	Fastening Set	Mass (g)	Part No.
Swivel Foot with holes-PA 6 Base (pcs)	80	50	M12x130	45	100	9000		217	5.22.80.12.130.DH
Swivel Foot with holes-PA 6 Base (set)			M12x130				2xDN	291	5.22.80.12.130.DH.ST
Swivel Foot with holes-PA 6 Base (pcs)			M16x130					297	5.22.80.16.130.DH
Swivel Foot with holes-PA 6 Base (set)			M16x130				2xDN	371	5.22.80.16.130.DH.ST



Floor Elements

Leveling Foot-Fixed Foot



Fixed foot have a non-moving connection between base and spindle.

Material and Color: Base Plate-steel, electrophoresis, black Spindle-zinc plated steel Pad-black rubber

Fixed Foot

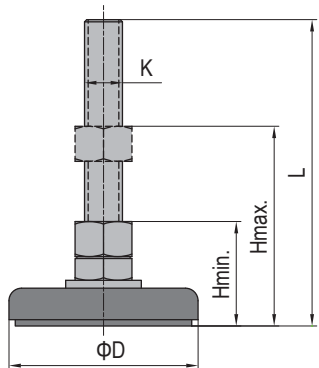

Description	D (mm)	KxL (mm)	H min. (mm)	H max. (mm)	Max. Static Load (N)	Mass (g)	Part No.
Fixed Foot-Steel Base	40	M12x70	35	50	4000	124	5.23.40.12.70
	60	M12x70	35	50	7000	181	5.23.60.12.70
		M14x70	38	50		225	5.23.60.14.70
	80	M12x70	35	50	9000	220	5.23.80.12.70
		M12x110	35	80		240	5.23.80.12.110
		M14x70	38	50		283	5.23.80.14.70

Ad:M14 Fixed Foot should use an end cap with a punched hole

Leveling Foot-Pivot Foot



To support structure where gradual height adjustment is needed, the pivot foot has a small swiveling angle to fit slightly uneven floor. The connection between the pivot base and the spindle can be released with a tool.

Material: zinc plated steel/stainless steel



Pivot Foot

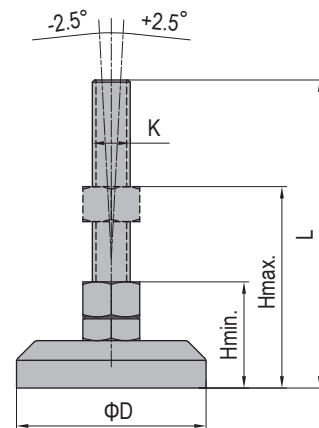

Description	D (mm)	KxL (mm)	H min. (mm)	H max. (mm)	Max. Static Load (N)	Mass (g)	Part No.
Pivot Foot-Zinc Plate Steel	40	M12x128	45	100	15000	241	5.24.40.12.130
		M14x128	45	100	17000	290	5.24.40.14.130
	60	M12x128	45	100	15000	475	5.24.60.12.130
		M14x128	45	100	17000	523	5.24.60.14.130
		M16x158	45	120	20000	596	5.24.60.16.160
	80	M20x178	50	130	25000	796	5.24.60.20.180
		M12x128	45	100	15000	670	5.24.80.12.130
		M16x158	45	120	20000	780	5.24.80.16.160
	M20x178	50	130	25000	945	5.24.80.20.180	
Pivot Foot-Stainless Steel	40	M12x128	45	100	15000	240	5.24.40.12.130.SS
		M12x128	45	100	15000	480	5.24.60.12.130.SS
	60	M16x158	45	120	20000	600	5.24.60.16.160.SS
		M20x178	50	130	25000	803	5.24.60.20.180.SS
		M12x128	45	100	15000	675	5.24.80.12.130.SS
	80	M16x158	45	120	20000	785	5.24.80.16.160.SS
		M20x178	50	130	25000	950	5.24.80.20.180.SS



Floor Elements

Cup pivot foot

To support structure where gradual height adjustment is needed, the pivot foot has a small swiveling angle to fit slightly uneven floor. The connection between the pivot base and the spindle can be released with a tool.

Material: zinc plated steel



Cup pivot foot

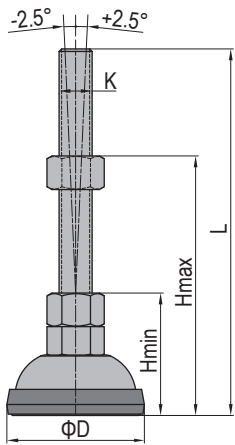

Description	D (mm)	KxL (mm)	H min. (mm)	H max. (mm)	Max. Static Load (N)	Mass (g)	Part No.
Cup pivot foot	45	M12x132	50	105	10000	148	5.25.40.12.130
	50					207	5.25.45.12.130

Floor Elements

Mounting Plate



To attach leveling foot to strut profile end, but it does not apply for connecting of castors.

Material: diecast aluminum



PG40-40x40
 PG45-45x45
 PG50-50x50

PG40-40x60
 PG45-45x60

PG40-40x80
 PG45-45x90

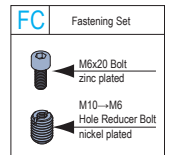
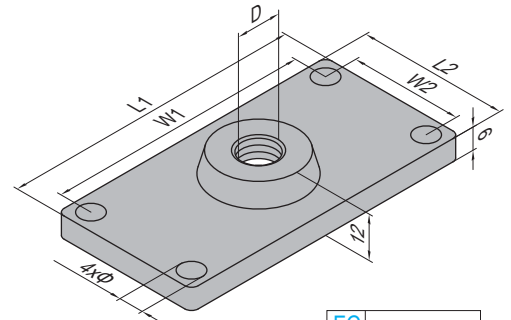
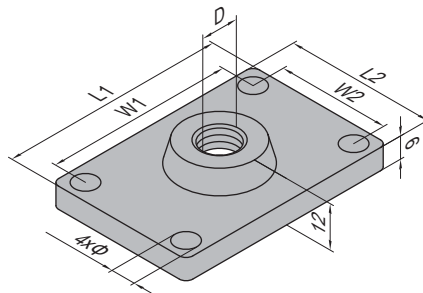
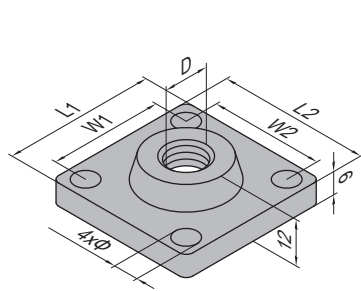
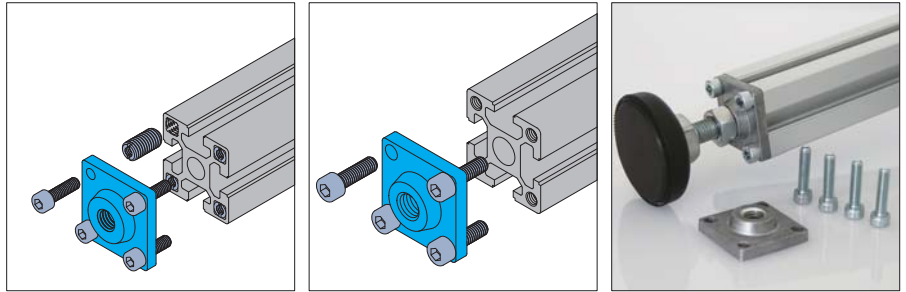

Description	D	Φ	L1 (mm)	L2 (mm)	W1 (mm)	W2 (mm)	Fastening Set	Mass (g)	Part No.
Mounting Plate-PG40-4040	M12	6.5	40	40	30	30	4x(M6x20)	51	5.31.40.4040
Mounting Plate-PG45-4545	M12	6.5	45	45	33	33	4xFC	97	5.31.45.4545
Mounting Plate-PG50-5050	M12	8.5	50	50	35	35	4x(M8x30)	130	5.31.50.5050
Mounting Plate-PG40-4060	M12	6.5	60	40	50	30	4x(M6x20)	67	5.31.40.4060
Mounting Plate-PG45-4560	M12	6.5	60	45	48	33	4xFC	108	5.31.45.4560
Mounting Plate-PG40-4080	M12	6.5	80	40	70	30	4x(M6x20)	78	5.31.40.4080.M12
	M16						4x(M6x20)	78	5.31.40.4080.M16
Mounting Plate-PG45-4590	M12	6.5	90	45	78	33	4xFC	131	5.31.45.4590.M12
	M16						4xFC	128	5.31.45.4590.M16



Floor Elements



To attach leveling foot or castor to strut profile end.

Material and Color: spray coating steel, silver



PG40-4040
PG45-4545
PG50-5050

PG40-4060
PG45-4560

PG30-3060
PG40-4080
PG45-4590
PG50-50100

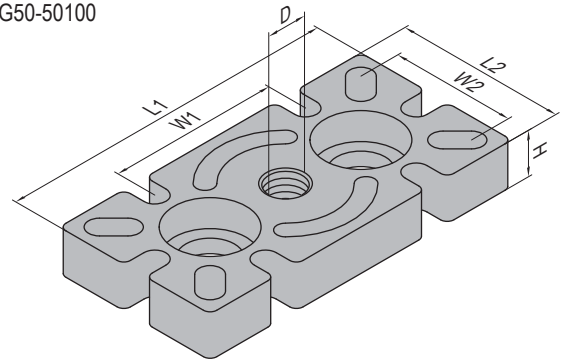
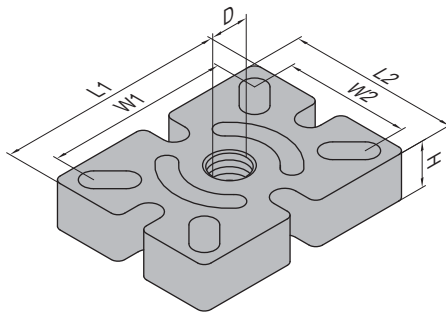
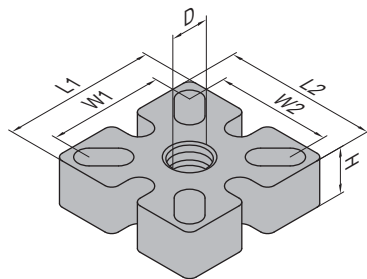
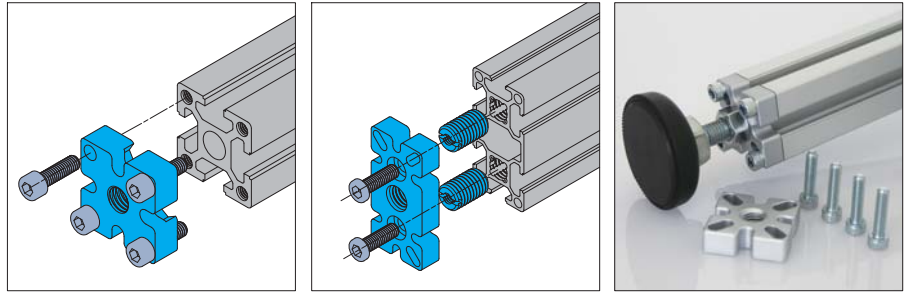

FI	Fastening Set	FZ	Fastening Set
	M6x25 Bolt zinc plated		M6x20 Bolt zinc plated
	M10-M6 Hole Reducer Bolt nickel plated		M12-M6 Hole Reducer Bolt nickel plated

Description	D	L1 (mm)	L2 (mm)	W1 (mm)	W2 (mm)	H (mm)	Fastening Set	Mass (g)	Part No.
Mounting Plate-PG40-4040	M12	40	40	30	30	12	4x(M6x20)	128	5.32.40.4040
Mounting Plate-PG45-4545	M12	45	45	33	33	12	4xFI	203	5.32.45.4545
Mounting Plate-PG50-5050	M12	50	50	35	35	12	4x(M8x20)	218	5.32.50.5050
Mounting Plate-PG40-4060	M12	60	40	50	30	12	4x(M6x20)	176	5.32.40.4060
Mounting Plate-PG45-4560	M12	60	45	48	33	12	4xFI	220	5.32.45.4560
Mounting Plate-PG30-3060	M12	60	30	30	23	10	2xFZ	133	5.32.30.3060
Mounting Plate-PG40-4080	M12	80	40	40	30	12	2x(M14x25)	272	5.32.40.4080.M12
	M16							270	5.32.40.4080.M16
Mounting Plate-PG45-4590	M12	90	45	45	33	12	2x(M14x25)	332	5.32.45.4590.M12
	M16							330	5.32.45.4590.M16
Mounting Plate-PG50-50100	M12	100	50	50	35	12	2x(M14x25)	332	5.32.50.50100.M12
	M16							329	5.32.50.50100.M16
	M20							327	5.32.50.50100.M20



Floor Elements

Mounting Plate



To attach leveling foot or castor to strut profile end.

Material: spray coating steel, sliver

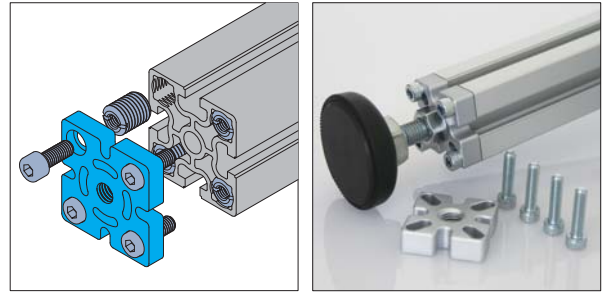
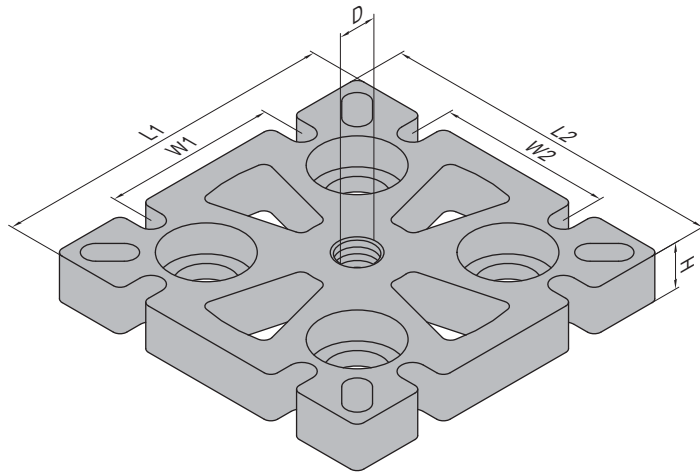

FY	Fastening Set	FZ	Fastening Set
	M8x20 Bolt zinc plated		M6x20 Bolt zinc plated
	M16→M8 Hole Reducer Bolt nickel plated		M12→M6 Hole Reducer Bolt nickel plated

Description	D	L1 (mm)	L2 (mm)	W1 (mm)	W2 (mm)	H (mm)	Fastening Set	Mass (g)	Part No.
Mounting Plate-PG30-6060	M12	60	60	30	30	10	4xFZ	232	5.32.30.6060.M12
	M16							230	5.32.30.6060.M16
Mounting Plate-PG40-8080	M12	80	80	40	40	12	4x(M14x25)	534	5.32.40.8080.M12
	M16							532	5.32.40.8080.M16
	M20							530	5.32.40.8080.M20
Mounting Plate-PG45-9090	M12	90	90	45	45	12	4x(M14x25)	664	5.32.45.9090.M12
	M16							661	5.32.45.9090.M16
	M20							659	5.32.45.9090.M20
Mounting Plate-PG50-100100	M12	100	100	50	50	12	4x(M14x25)	725	5.32.50.100100.M12
	M16							722	5.32.50.100100.M16
	M20							720	5.32.50.100100.M20
Mounting Plate-PG60-6060	M12	60	60	40	40	10	4xFY	330	5.32.60.6060



Floor Elements



To attach leveling foot or castor to strut profile end.

Material: diecast zinc

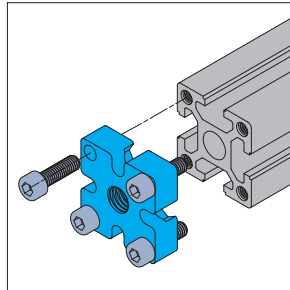

Reliability	★★★★
Efficiency	★★★★
Economical	★★★★

PG40-4040
PG45-4545

PG40-4080
PG45-4590

PG40-8080
PG45-9090

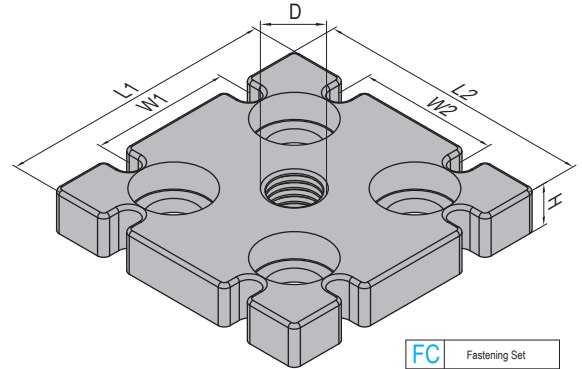
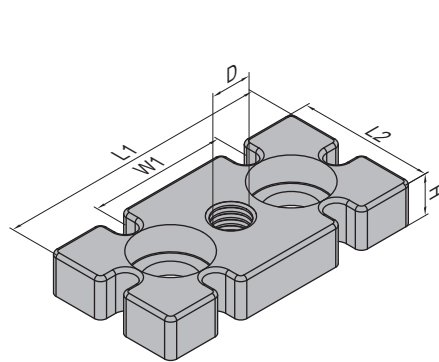
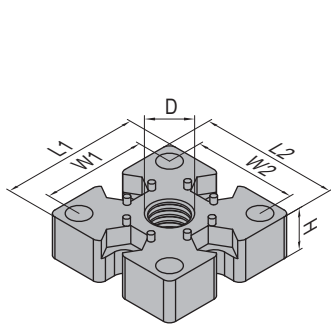

FC Fastening Set

- M6x20 Bolt zinc plated
- M10-M6 Hole Reducer Bolt nickel plated

Description	D	L1 (mm)	L2 (mm)	W1 (mm)	W2 (mm)	H (mm)	Fastening Set	Mass (g)	Part No.
Mounting Plate-PG40-4040	M12	40	40	30	30	12	4x(M6x20)	117	5.33.40.4040
Mounting Plate-PG45-4545	M12	45	45	33	33	12	4xFC	189	5.33.45.4545
Mounting Plate-PG40-4080	M12	80	40	40		12	2x(M14x25)	277	5.33.40.4080.M12
	M16							275	5.33.40.4080.M16
Mounting Plate-PG45-4590	M12	90	45	45		12	2x(M14x25)	344	5.33.45.4590.M12
	M16							342	5.33.45.4590.M16
Mounting Plate-PG40-8080	M12	80	80	40	40	12	4x(M14x25)	582	5.33.40.8080.M12
	M16							580	5.33.40.8080.M16
	M20							577	5.33.40.8080.M20
Mounting Plate-PG45-9090	M12	90	90	45	45	12	4x(M14x25)	714	5.33.45.9090.M12
	M16							712	5.33.45.9090.M16
	M20							709	5.33.45.9090.M20



Floor Elements









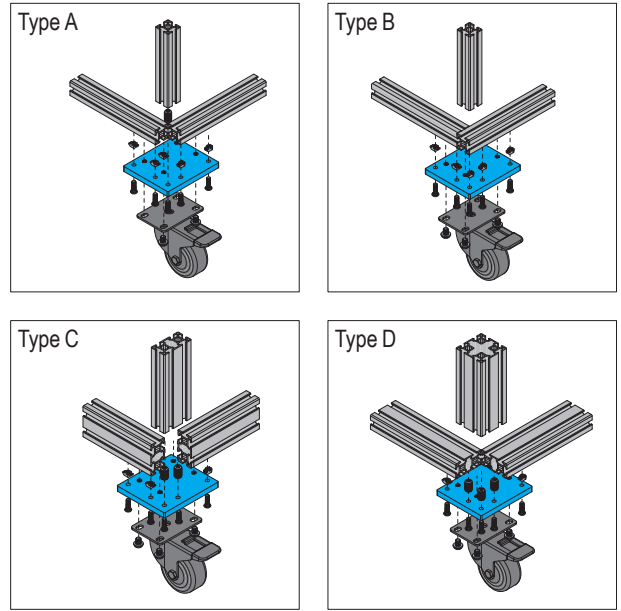
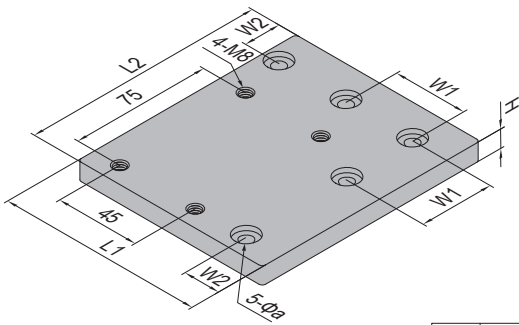









Castor Plate



The castor plate is used for attaching profiles to the castor with plate.

Material: zinc plated steel



GJ	Fastening Set	GK	Fastening Set	GL	Fastening Set	GM	Fastening Set	AM	Fastening Set	GN	Fastening Set
	M8x20 Bolt zinc plated		M8x25 Bolt zinc plated		M6x16 Bolt zinc plated		M6x20 Bolt zinc plated		M8x12 Bolt zinc plated		M8x25 Bolt zinc plated
	M8 Spring Washer zinc plated		M8 Spring Washer zinc plated		M6 Spring Washer zinc plated		M6 Spring Washer zinc plated		M8 Spring Washer zinc plated		M8 Spring Washer zinc plated
	M8 T Nut nickel plated		M8 T Nut nickel plated		M6 T Nut nickel plated		M6 T Nut nickel plated		M8 Washer zinc plated		M14-M8 Hole Reducer Bolt nickel plated

Description	PG	H (mm)	L1 (mm)	L2 (mm)	W1 (mm)	W2 (mm)	Φa (mm)	Fastening Set	Mass (g)	Part No.
Castor Plate A-PG30	PG30	10	105	120	30	15	7	4xGL+1xGM+4xAM	1056	5.34.30.STA
Castor Plate B-PG30								5xGL+4xAM	1049	5.34.30.STB
Castor Plate C-PG30								3xGL+2xGM+4xAM	1063	5.34.30.STC
Castor Plate D-PG30								2xGL+3xGM+4xAM	1070	5.34.30.STD
Castor Plate A-PG40	PG40	12	110	130	40	20	9	4xGJ+1xGN+4xAM	1229	5.34.40.STA
Castor Plate B-PG40								5xGJ+4xAM	1222	5.34.40.STB
Castor Plate C-PG40								3xGJ+2xGN+4xAM	1236	5.34.40.STC
Castor Plate D-PG40								2xGJ+3xGN+4xAM	1243	5.34.40.STD
Castor Plate A-PG45	PG45	12	120	130	45	22.5	9	4xGK+1xGN+4xAM	1237	5.34.45.STA
Castor Plate B-PG45								5xGK+4xAM	1230	5.34.45.STB
Castor Plate C-PG45								3xGK+2xGN+4xAM	1244	5.34.45.STC
Castor Plate D-PG45								2xGK+3xGN+4xAM	1251	5.34.45.STD



Floor Elements

Castor Plate-Heavy



The castor plate is used for attaching profiles to the castor with plate-Heavy.

Material: zinc plated steel

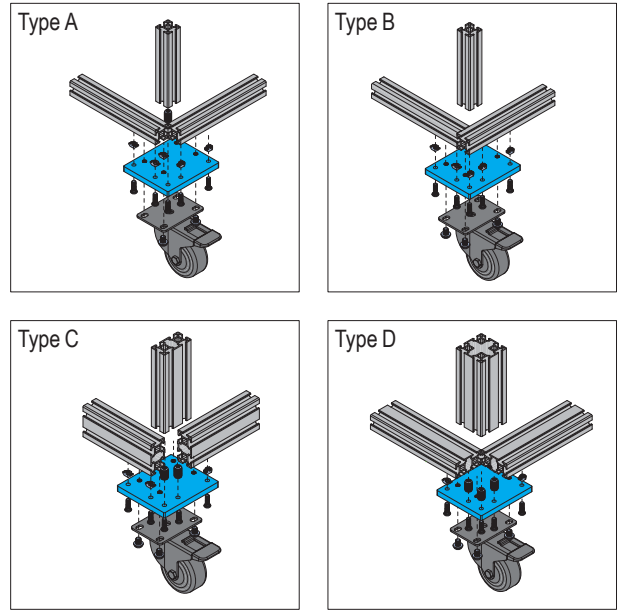
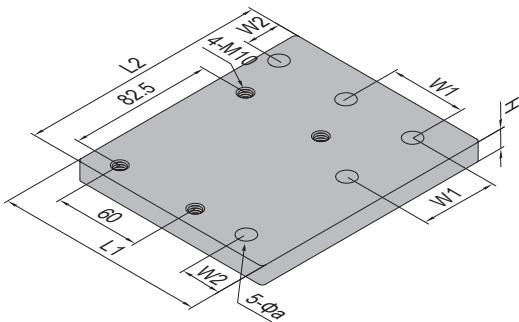

DO	Fastening Set	DQ	Fastening Set	DS	Fastening Set	DP	Fastening Set	DR	Fastening Set
	M6x20 Bolt zinc plated		M6x20 Bolt zinc plated		M10x16 Bolt zinc plated		M8x25 Bolt zinc plated		M8x25 Bolt zinc plated
	M6 Spring Washer zinc plated		M6 Spring Washer zinc plated		M10 Washer zinc plated		M8 Spring Washer zinc plated		M8 Spring Washer zinc plated
	M6 Washer zinc plated		M6 Washer zinc plated				M8 Washer zinc plated		M8 Washer zinc plated
	M6 T Nut nickel plated		M12-M6 Hole Reducer Bolt nickel plated				M8 T Nut nickel plated		M8 T Nut nickel plated

Description	PG	H (mm)	L1 (mm)	L2 (mm)	W1 (mm)	W2 (mm)	Φa (mm)	Fastening Set	Mass (g)	Part No.
Castor Plate-Heavy A-PG30	PG30	10	120	135	30	15	7	4xDO+1xDQ+4xDS	1364	5.34.30.H.STA
Castor Plate-Heavy B-PG30								5xDO+4xDS	1356	5.34.30.H.STB
Castor Plate-Heavy C-PG30								3xDO+2xDQ+4xDS	1372	5.34.30.H.STC
Castor Plate-Heavy D-PG30								2xDO+3xDQ+4xDS	1380	5.34.30.H.STD
Castor Plate-Heavy A-PG40	PG40	12	125	145	40	20	9	4xDP+1xDR+4xDS	1834	5.34.40.H.STA
Castor Plate-Heavy B-PG40								5xDP+4xDS	1826	5.34.40.H.STB
Castor Plate-Heavy C-PG40								3xDP+2xDR+4xDS	1842	5.34.40.H.STC
Castor Plate-Heavy D-PG40								2xDP+3xDR+4xDS	1850	5.34.40.H.STD
Castor Plate-Heavy A-PG45	PG45	12	135	145	45	22.5	9	4xDP+1xDR+4xDS	1969	5.34.45.H.STA
Castor Plate-Heavy B-PG45								5xDP+4xDS	1972	5.34.45.H.STB
Castor Plate-Heavy C-PG45								3xDP+2xDR+4xDS	1977	5.34.45.H.STC
Castor Plate-Heavy D-PG45								2xDP+3xDR+4xDS	1985	5.34.45.H.STD



Floor Elements

Castor Plate



The castor plate is used for attaching profiles to the castor with thread.

Material: zinc plated steel

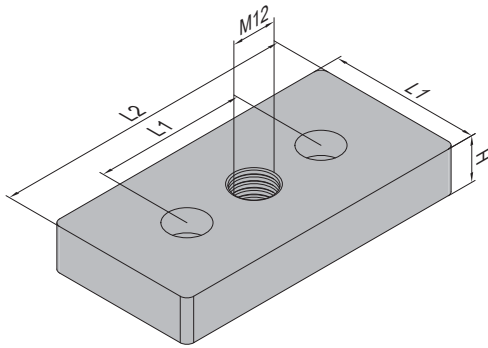
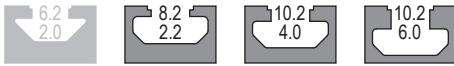
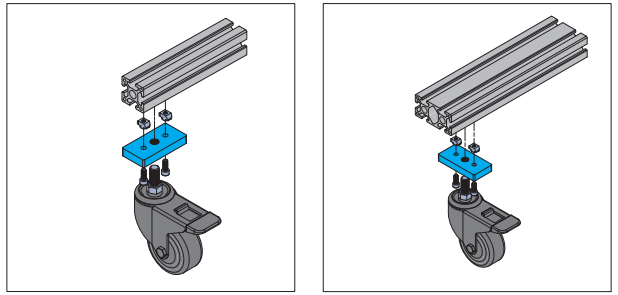

FS	Fastening Set	CQ	Fastening Set
	M6x10 Bolt zinc plated		M6x16 Bolt zinc plated
	M6 T Nut nickel plated		M6 T Nut nickel plated

Description	PG	H (mm)	L1 (mm)	L2 (mm)	Fastening Set	Mass (g)	Part No.
Castor Plate-PG30	PG30	10	30	60	2xFS	162	5.35.30.ST
Castor Plate-PG40	PG40	12	40	80	2xCQ	296	5.35.40.ST
Castor Plate-PG45	PG45	12	45	90	2xCQ	377	5.35.45.ST

When the castor is installed with this castor plate, the profile need be machined with a $\Phi 12.5$ and 20mm depth hole at the corresponding position to the thread of the castor.

Floor Elements

Castor

Material and Color: Base-carbon steel, plastic powder coated, black
Wheel-polyurethane(Heavy duty - Nylon)

Castor-Thread-Universal

Castor-Thread-Brake-Universal

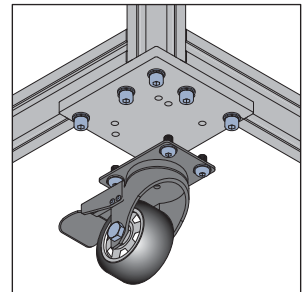
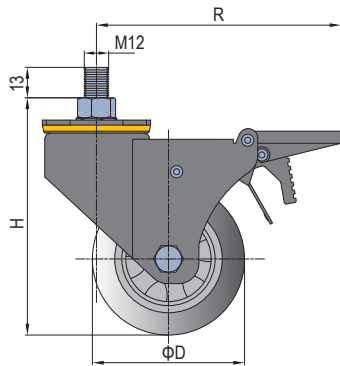
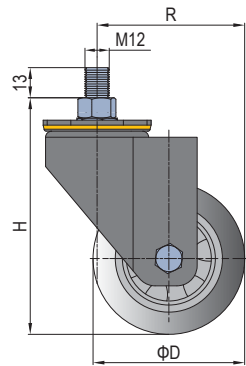

Castor-Plate-Universal-Heavy

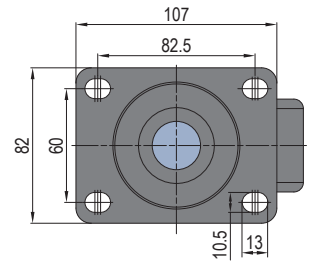
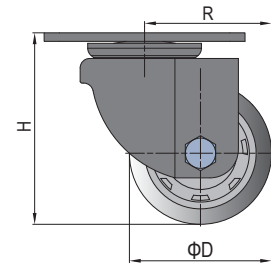

Castor-Plate-Fixed-Heavy

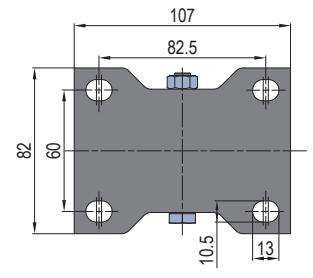
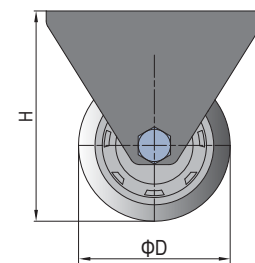

Castor-Plate-Universal

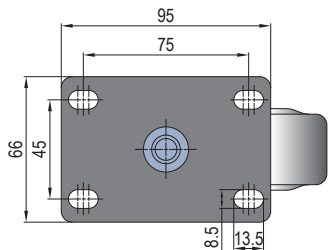
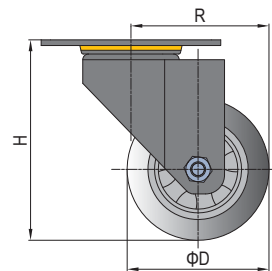

Castor-Plate-Fixed

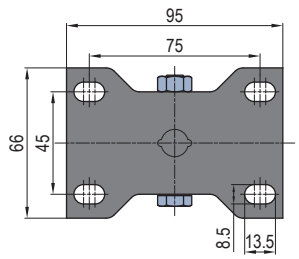
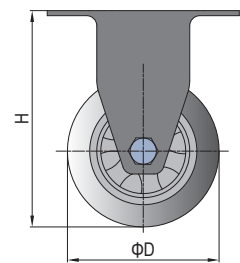

Castor-Plate-Brake

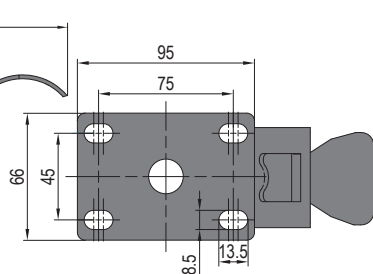
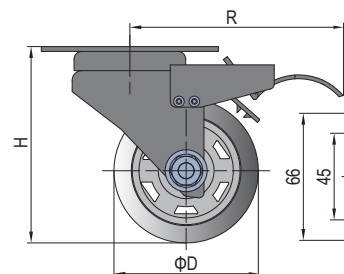

Description	Wheel Width (mm)	D (mm)	R (mm)	H (mm)	Load (N)	Mass (g)	Part No.
Castor-Thread-Universal	32	63	63	104	800	550	5.41.63.M12
		75	73	119	1050	670	5.41.75.M12
		100	87	142	1350	790	5.41.100.M12
Castor-Thread-Brake-Universal	32	63	112	104	800	650	5.41.63.M12B
		75	112	119	1050	770	5.41.75.M12B
		100	122	142	1350	930	5.41.100.M12B
Castor-Plate-Universal	32	63	63	92	800	570	5.41.63U
		75	73	107	1050	690	5.41.75U
		100	87	130	1350	870	5.41.100U
Castor-Plate-Fixed	32	63		92	800	370	5.41.63F
		75		107	1050	490	5.41.75F
		100		130	1350	670	5.41.100F
Castor-Plate-Brake	32	63	118	92	800	670	5.41.63B
		75	118	107	1050	790	5.41.75B
		100	127	130	1350	970	5.41.100B
Castor-Plate-Universal-Heavy	50	75	65	104	6000	1150	5.41.75UH
Castor-Plate-Fixed-Heavy	50	75		104	6000	950	5.41.75FH

Floor Elements

Base Angle

To improve stability of structure supported by leveling foot.

Material: steel, black electrophoresis



Base Angle-Left/Right

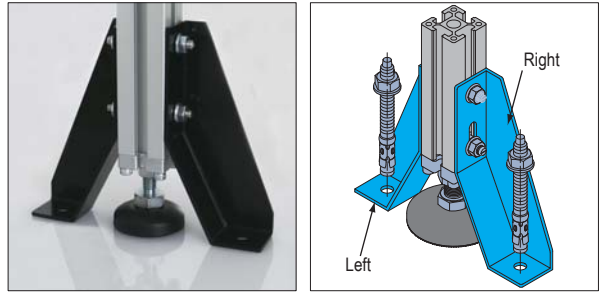
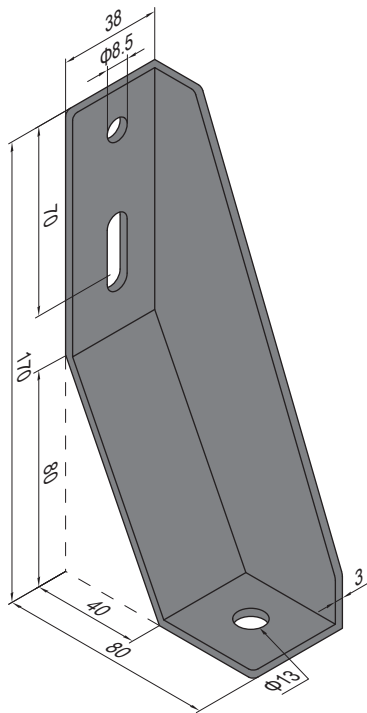

C	Fastening Set	AA	Fastening Set
	M8 Flange Nut zinc plated		M10x100 expansion bolt zinc plated
	M8x20 T Bolt nickel plated		

Description	Fastening Set	Mass (g)	Part No.
Base Angle-Left (pcs)		346	5.51.L
Base Angle-Left (set)	2xC+1xAA	473	5.51.L.ST
Base Angle-Right (pcs)		346	5.51.R
Base Angle-Right (set)	2xC+1xAA	473	5.51.R.ST
Base Angle-L+R (pair)		692	5.51.P
Base Angle-L+R (set)	4xC+2xAA	946	5.51.P.ST

Floor Elements

L Base

L base is to fix the profile on the floor and adjust the height of the profile to the floor.

Material: diecast aluminum, black electrophoresis

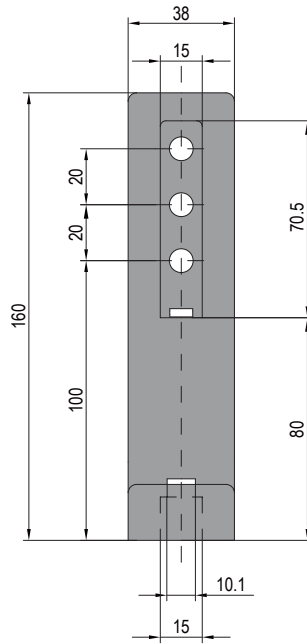
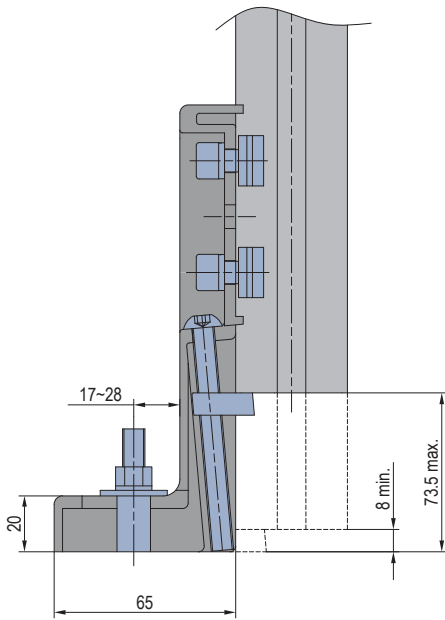
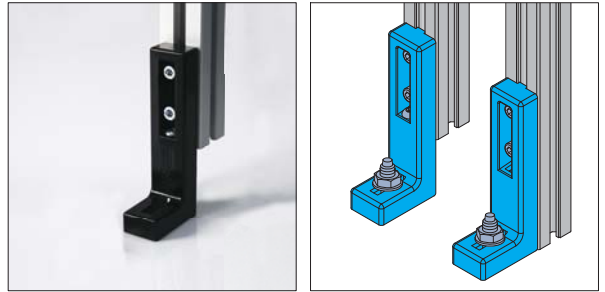

DI	Fastening Set	DM	Fastening Set	DN	Fastening Set
	M8x16 Bolt zinc plated		M8x20 Bolt zinc plated		M10x100 expansion bolt zinc plated
	M8 Spring Washer zinc plated		M8 Spring Washer zinc plated		
	M8 Pre-set Nut nickel plated		M8 Pre-set Nut nickel plated		

Description	Fastening Set	Mass (g)	Part No.
L Base (pcs)		276	5.52.10
L Base-PG40 (set)	2xDI+1xDN	343	5.52.10.04.ST
L Base-PG45 (set)	2xDM+1xDN	346	5.52.10.06.ST



Floor Elements

Foot and Castor Components



Light

Wheel-polyurethane, Foot-steel, black electrophoresis, plate-diecast aluminum

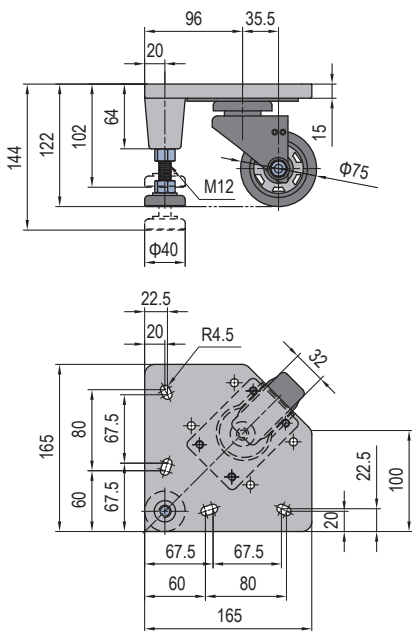

Heavy

Wheel-PA, Foot-zinc plated steel, plate-cast steel, silver color

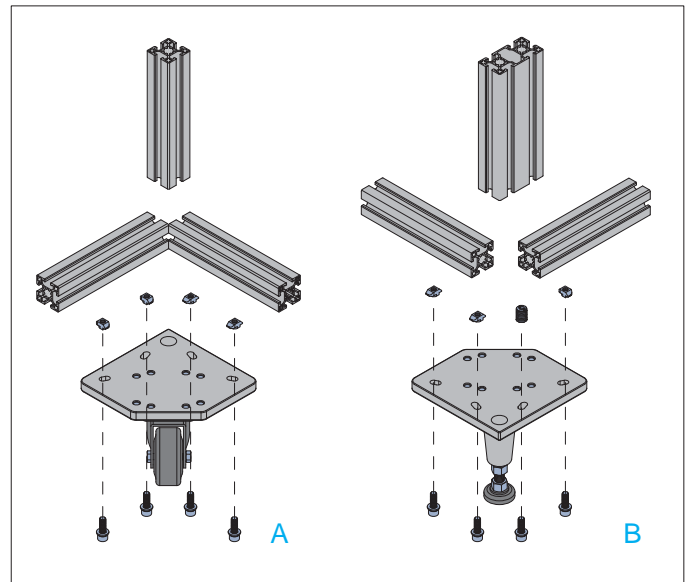
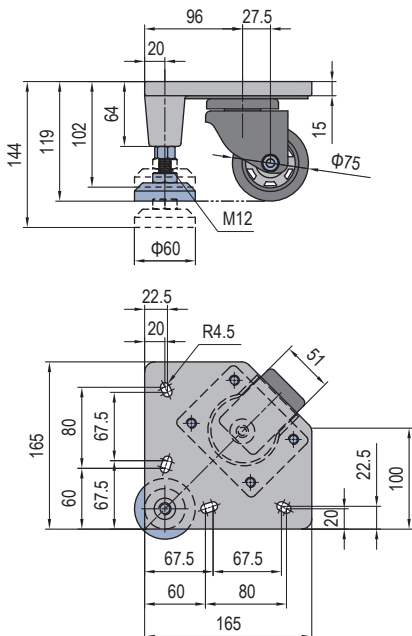

Code	Fastening Set
AF	Fastening Set <ul style="list-style-type: none"> M8x25 Bolt zinc plated M8 Spring Washer zinc plated M8 Washer zinc plated M14→M8 Hole Reducer Bolt nickel plated
AG	Fastening Set <ul style="list-style-type: none"> M8x30 Bolt zinc plated M8 Spring Washer zinc plated M8 Washer zinc plated M14→M8 Hole Reducer Bolt nickel plated
J	Fastening Set <ul style="list-style-type: none"> M8x25 Bolt zinc plated M8 Spring Washer zinc plated M8 Washer zinc plated M8 T Nut nickel plated
W	Fastening Set <ul style="list-style-type: none"> M8x30 Bolt zinc plated M8 Spring Washer zinc plated M8 Washer zinc plated M8 T Nut nickel plated

Description	Fastening Set	Load (N)	Mass (g)	Part No.
Light Weight (pcs)			3900	5.61.L
Light Weight (set)	4xJ	1050	3950	5.61.40.L.STA
	3xJ+1xAF		3950	5.61.40.L.STB
	4xW		3950	5.61.45.L.STA
	3xW+1xAG		3950	5.61.45.L.STB
Heavy Weight (pcs)			4600	5.61.H
Heavy Weight (set)	4xJ	6000	4650	5.61.40.H.STA
	3xJ+1xAF		4650	5.61.40.H.STB
	4xW		4650	5.61.45.H.STA
	3xW+1xAG		4650	5.61.45.H.STB



Floor Elements

Leveling Castor

Material: Base-Carbon steel, Case-Aluminum, Wheel-Nylon 6

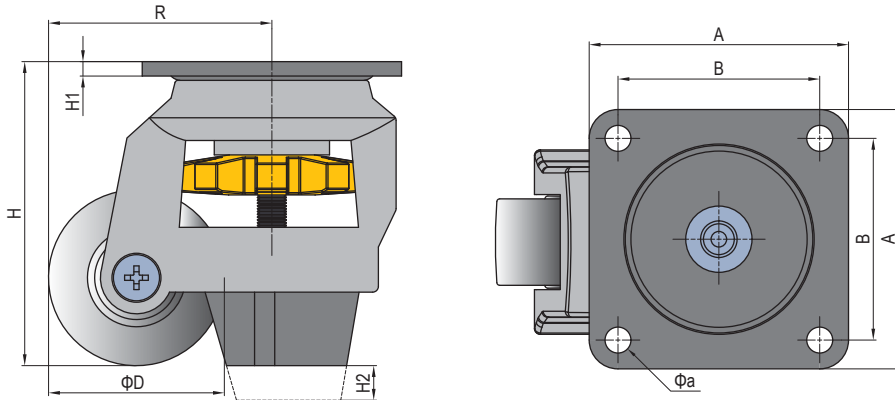

Description	Wheel Width (mm)	D (mm)	R (mm)	H (mm)	H ₁ (mm)	H ₂ (mm)	A (mm)	B (mm)	a (mm)	Load (N)	Mass (kg)	Part No.
Leveling Castor	22	50	62	83	4	10	73	58	7	1700	0.69	5.62.60F
	29	62	77	102	5	12	90	70	9.5	3400	1.31	5.62.80F
	31	72	91	121	6	15	95	70	11.5	6700	1.75	5.62.120F





6.11-6.41

T Slot Reducing Profile

Panel Mounting Block

Panel Mounting Strip

Mounting Block

6

Panel Installation Elements



P. 6-02



P. 6-03



P. 6-04



P. 6-05



Panel Installation Elements

T Slot Reducing Profile

To reduce slot width for panel installation.

Material and Color: black PVC



T Slot Reducing Profile-6

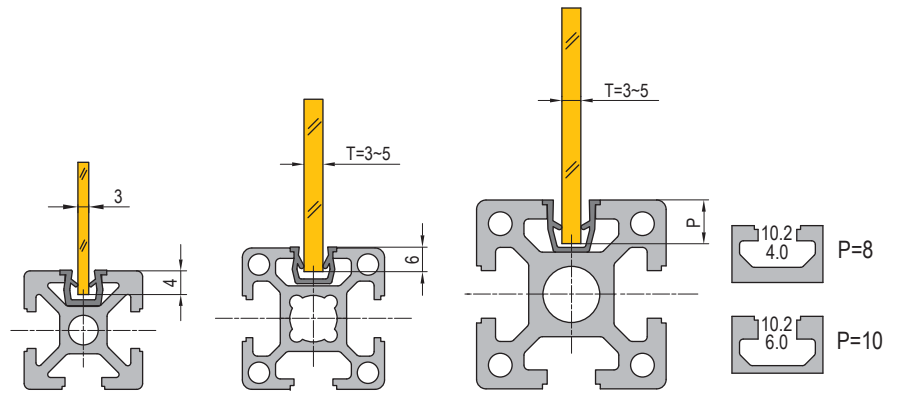
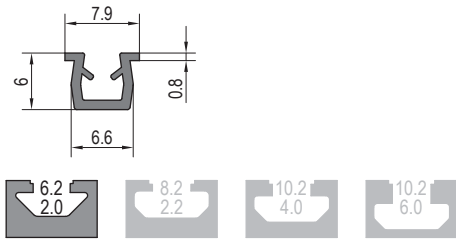

T Slot Reducing Profile-8

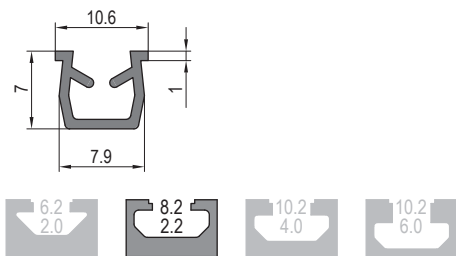

Description	Mass (g/m)	Delivery Length	Part No.
T Slot Reducing Profile-6	25	2000mm/bar	6.11.06
T Slot Reducing Profile-8	51		6.11.08
T Slot Reducing Profile-10	64		6.11.10

T Slot Reducing Profile-10

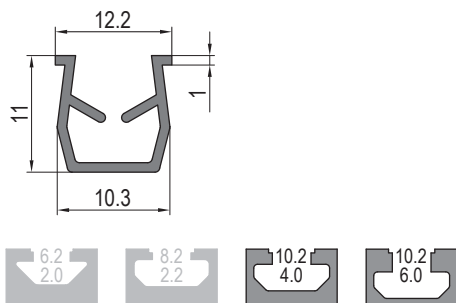

Panel Installation Elements

Panel Mounting Block

The block is used to attach the panel with various thickness to the profile.

Material and Color: Block-black PVC Nut-stainless steel

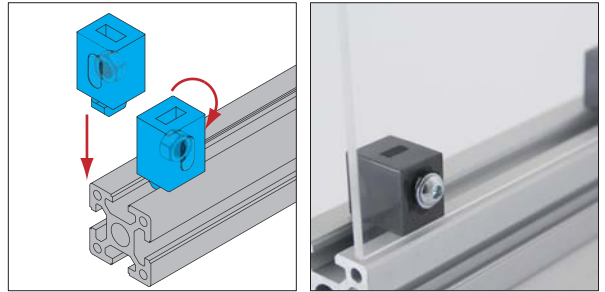

Panel Mounting Block-6

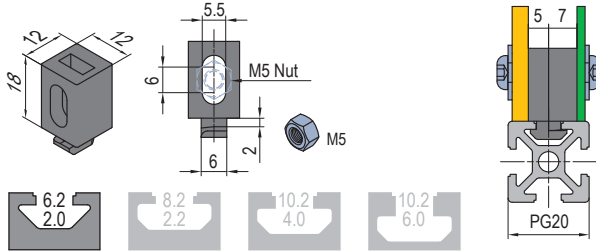

FM	Fastening Set	FN	Fastening Set	FP	Fastening Set
	M5x14 Bolt zinc plated		M6x16 Bolt zinc plated		M6x25 Bolt zinc plated
	M5 Washer zinc plated		M6 Washer zinc plated		M6 Washer zinc plated

Panel Mounting Block-8

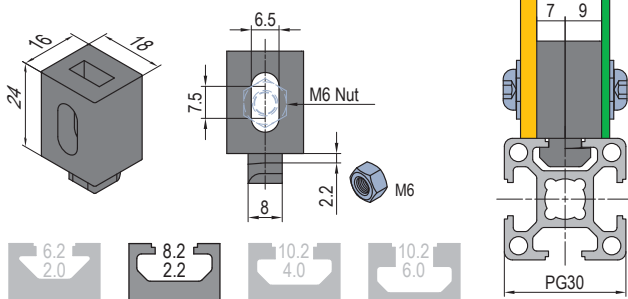

Description	PG	Fastening Set	Mass (g)	Part No.
Panel Mounting Block-6 (pcs)	PG20		4.4	6.21.06
Panel Mounting Block-6 (set)		1xFM	7	6.21.06.ST
Panel Mounting Block-8 (pcs)	PG30		9	6.21.08
Panel Mounting Block-8 (set)		1xFN	13.5	6.21.08.ST
Panel Mounting Block-10-4 (pcs)	PG40		15.8	6.21.10.04
Panel Mounting Block-10-4 (set)		1xFP	23.8	6.21.10.04.ST
Panel Mounting Block-10-6 (pcs)	PG45/50/60		20	6.21.10.06
Panel Mounting Block-10-6 (set)		1xFP	29	6.21.10.06.ST

Panel Mounting Block-10-4

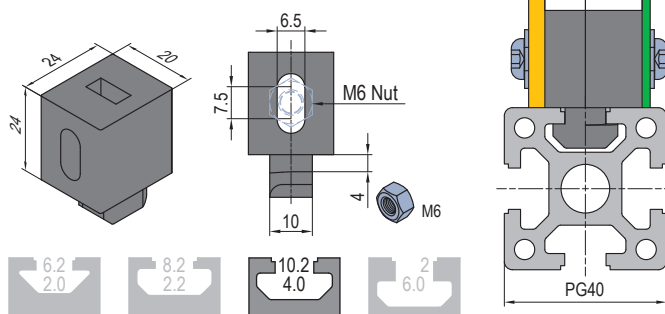

Panel Mounting Block-10-6

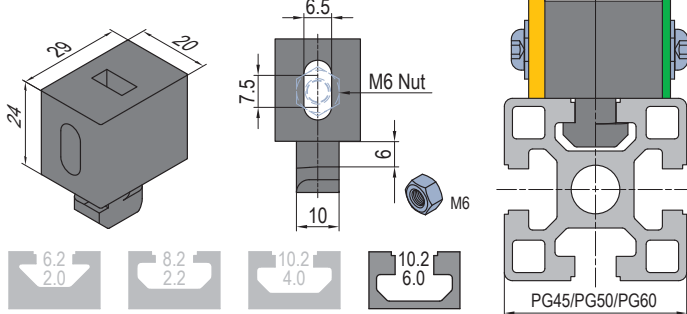

Panel Installation Elements

Panel Mounting Strip

To attach the panel with 3mm and 5mm thickness to the profile, widely used in clean room.

Material and Color: gray PVC



Panel Mounting Strip-8-5

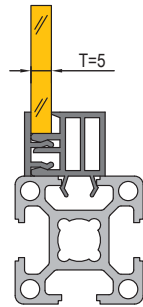
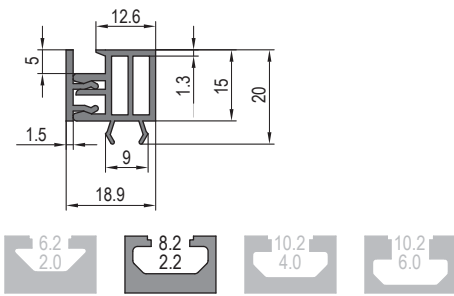

Panel Mounting Strip-10-4-3

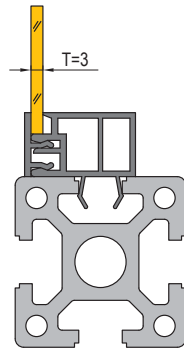
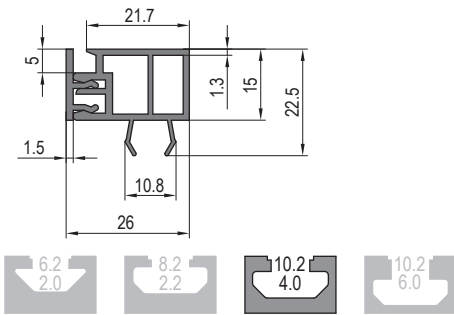

Panel Mounting Strip-10-4-5

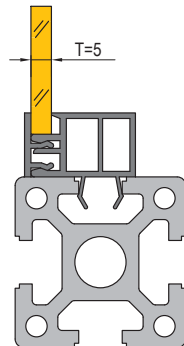
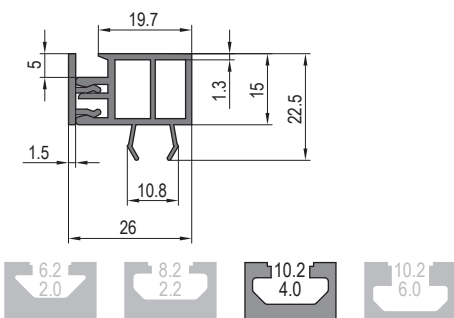

Description	PG	Mass	Delivery length	Part No.
Panel Mounting Strip-8-5	PG30	220	2000mm/bar	6.31.08.02
Panel Mounting Strip-10-4-3	PG40	273		6.31.10.04.01
Panel Mounting Strip-10-4-5		260		6.31.10.04.02



Panel Installation Elements

Mounting Block

Mounting block is used for fixing the mesh of $\Phi 4$ to the standard profiles, which has a better physical property.

Material: diecast zinc

Mounting Block-8

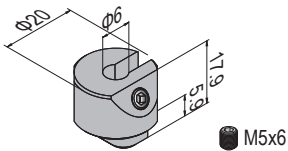

Mounting Block-10-4

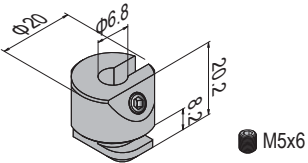

Mounting Block-10-6

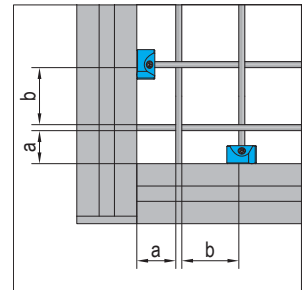
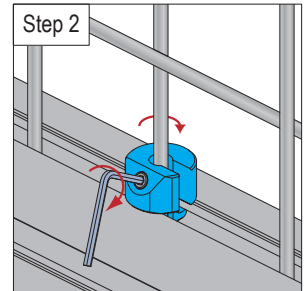
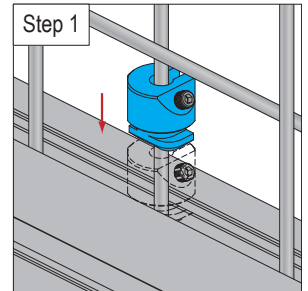
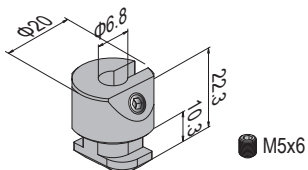

Description	PG	Mass (g/pcs)	Part No.
Mounting Block-8(with top thread)	PG30	19	6.41.08.01
Mounting Block-10-4(with top thread)	PG40	21	6.41.10.04.01
Mounting Block-10-6(with top thread)	PG45/50/60	23	6.41.10.06.01

Note: The distance (a) between the nearest meshes and profiles have to be more than 20mm and less than $b+5\text{mm}$ (b is the distance of the meshes). And the optimum distance between mounting blocks is 300mm to ensure the structure intensity.



7.11-7.51

Handle

Hinge

Lock

Magnet Catch

Door Lock

Sliding Door Profile



Door and Window Elements



P. 7-02



P. 7-03



P. 7-04

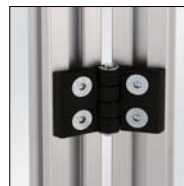

P. 7-05



P. 7-06



P. 7-09



P. 7-10

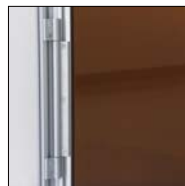

P. 7-11



P. 7-12



P. 7-14



P. 7-16









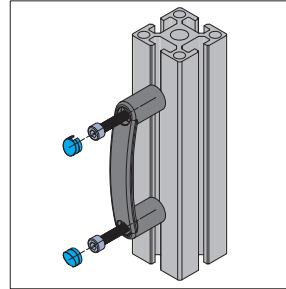
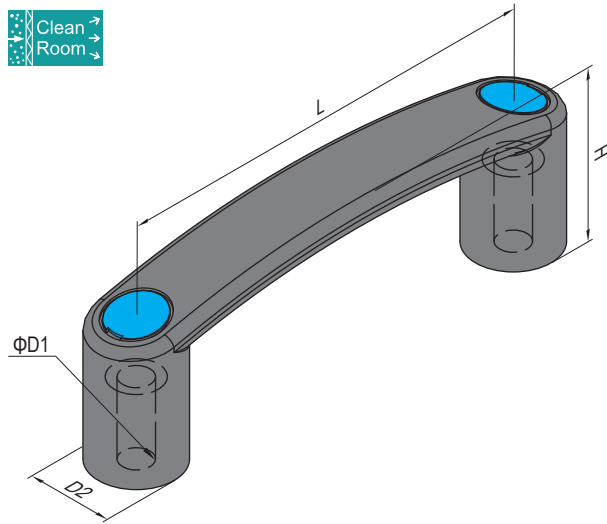

P. 7-17





















Door and Window Elements

Handle

Material and Color: PA6, black



CA	Fastening Set	CB	Fastening Set	CD	Fastening Set	CE	Fastening Set
	M5x25 Bolt zinc plated		M6x25 Bolt zinc plated		M8x25 Bolt zinc plated		M8x30 Bolt zinc plated
	M5 T Nut nickel plated		M6 T Nut nickel plated		M8 T Nut nickel plated		M8 T Nut nickel plated

Description	PG	L (mm)	H (mm)	D1 (mm)	D2 (mm)	Fastening Set	Cap Color	Mass (g)	Part No.
PA6 Handle-90 (pcs)	PG15/20	90	36	6.5	18			23	7.11.90.06.BE
PA6 Handle-90 (set)						2xCA		41	7.11.90.06.BE.ST
PA6 Handle-90 (pcs)								23	7.11.90.06.BK
PA6 Handle-90 (set)						2xCB		41	7.11.90.06.BK.ST
PA6 Handle-90 (pcs)	PG30	90	36	6.5	18			23	7.11.90.08.BE
PA6 Handle-90 (set)						2xCB		45	7.11.90.08.BE.ST
PA6 Handle-90 (pcs)								23	7.11.90.08.BK
PA6 Handle-90 (set)						2xCB		45	7.11.90.08.BK.ST
PA6 Handle-120 (pcs)	PG30	120	40	8.5	25			45	7.11.120.08.BE
PA6 Handle-120 (set)						2xCB		68	7.11.120.08.BE.ST
PA6 Handle-120 (pcs)								45	7.11.120.08.BK
PA6 Handle-120 (set)						2xCB		68	7.11.120.08.BK.ST
PA6 Handle-120 (pcs)	PG40	120	40	8.5	25			45	7.11.120.10.04.BE
PA6 Handle-120 (set)						2xCD		88	7.11.120.10.04.BE.ST
PA6 Handle-120 (pcs)								45	7.11.120.10.04.BK
PA6 Handle-120 (set)						2xCD		88	7.11.120.10.04.BK.ST
PA6 Handle-120 (pcs)	PG45/50/60	120	40	8.5	25			45	7.11.120.10.06.BE
PA6 Handle-120 (set)						2xCE		104	7.11.120.10.06.BE.ST
PA6 Handle-120 (pcs)								45	7.11.120.10.06.BK
PA6 Handle-120 (set)						2xCE		104	7.11.120.10.06.BK.ST

Door and Window Elements

Guard Wing Handle

Material and Color: PA6, black

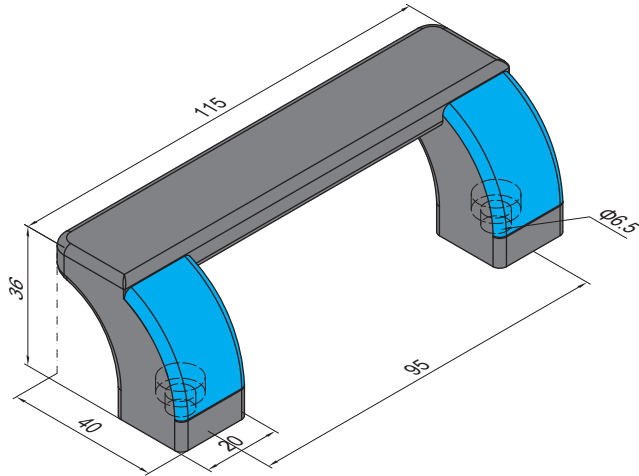
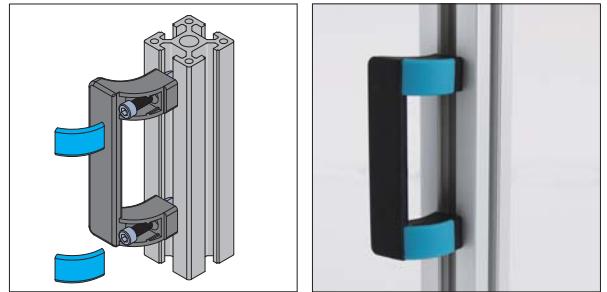
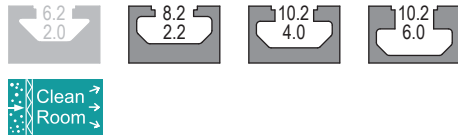

CP	Fastening Set	CQ	Fastening Set
	M6x12 Bolt zinc plated		M6x16 Bolt zinc plated
	M6 T Nut nickel plated		M6 T Nut nickel plated

Description	PG	Fastening Set	Cap Color	Mass (g)	Part No.
Guard Wing Handle -95 (pc)	PG30			70	7.12.95.08.BE
Guard Wing Handle -95 (set)		2xCP		88	7.12.95.08.BE.ST
Guard Wing Handle -95 (pc)				70	7.12.95.08.BK
Guard Wing Handle -95 (set)		2xCP		88	7.12.95.08.BK.ST
Guard Wing Handle -95 (pc)	PG40/45/50/60			70	7.12.95.10.BE
Guard Wing Handle -95 (set)		2xCQ		96	7.12.95.10.BE.ST
Guard Wing Handle -95 (pc)				70	7.12.95.10.BK
Guard Wing Handle -95 (set)		2xCQ		96	7.12.95.10.BK.ST









Door and Window Elements

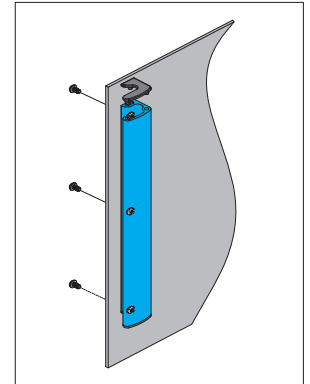
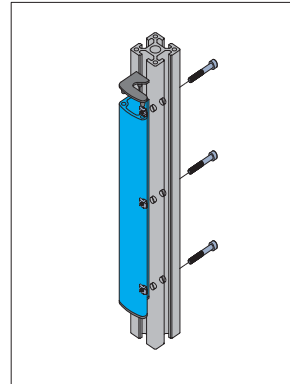
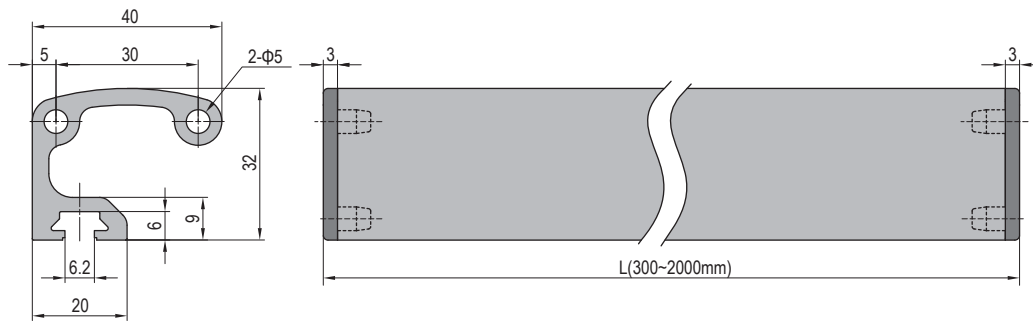
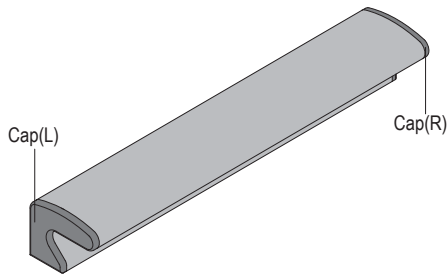







Aluminum Handle



Material: handle-aluminum Cap-ABS Cap Color: gray and black



PA	Fastening Set	PB	Fastening Set
	M5x10 Bolt zinc plated		M5x35 Bolt zinc plated
	M5 Washer zinc plated		M5 T Nut nickel plated
	M5 T Nut nickel plated		

Application	Description	Cap Color	L (mm)	Fastening Set	Mass (g)	Part No.	
4mm Panel	Aluminum Handle (pc)		300		216	7.13.P.GY	
	Aluminum Handle (set)			3×PA	224	7.13.P.GY.ST	
	Aluminum Handle (pc)				216	7.13.P.BK	
	Aluminum Handle (set)			3×PA	224	7.13.P.BK.ST	
PG40/45	Aluminum Handle (pc)					216	7.13.10.GY
	Aluminum Handle (set)			3×PB	231	7.13.10.GY.ST	
	Aluminum Handle (pc)					216	7.13.10.BK
	Aluminum Handle (set)			3×PB	231	7.13.10.BK.ST	

Note:1. Single supply including 3 of M5 T Nuts (Reference No.2.21.06.M5).

2. The length could be customized according to customer's requirements(300~2000mm).

ex: 7.13.P.GY - 500

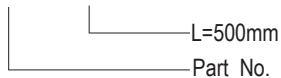

Door and Window Elements

Hinge

Material and Color: black PA6



Hinge-PA6

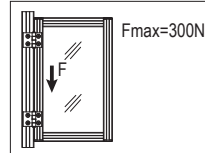
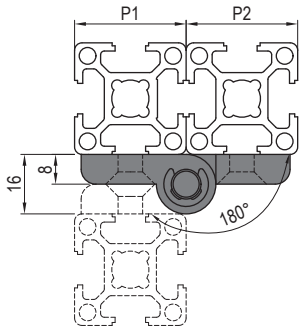
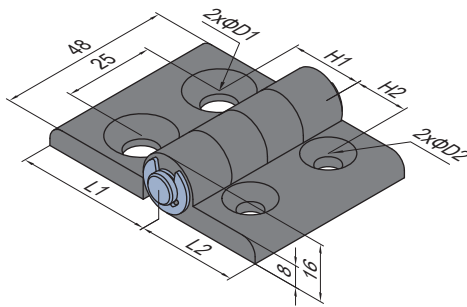

FG	Fastening Set	FL	Fastening Set
	M8x16 Bolt zinc plated		M6x14 Bolt zinc plated
	M8 T Nut nickel plated		M6 T Nut nickel plated

Description	H1 (mm)	H2 (mm)	L1 (mm)	L2 (mm)	D1 (mm)	D2 (mm)	Fastening Set	Mass (g)	Part No.
30/30 (pcs)	15	15	28	28	6.5	6.5		39	7.21.30.30
30/30 (set)							4xFL	73	7.21.30.30.ST
30/40 (pcs)	20	15	38	28	8.5	6.5		42	7.21.30.40
30/40 (set)							2xFG+2xFL	88	7.21.30.40.ST
30/45 (pcs)	22.5	15	43	28	8.5	6.5		44	7.21.30.45
30/45 (set)							2xFG+2xFL	81	7.21.30.45.ST
40/40 (pcs)	20	20	38	38	8.5	8.5		45	7.21.40.40
40/40 (set)							4xFG	108	7.21.40.40.ST
40/45 (pcs)	22.5	20	43	38	8.5	8.5		47	7.21.40.45
40/45 (set)							4xFG	110	7.21.40.45.ST
45/45 (pcs)	22.5	22.5	43	43	8.5	8.5		49	7.21.45.45
45/45 (set)							4xFG	112	7.21.45.45.ST



Door and Window Elements

Hinge



Material and Color: aluminum, nature anodized



Light Hinge-Aluminum Countersink Hole

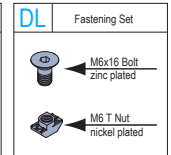
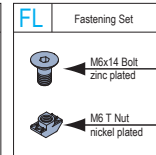
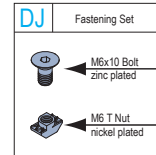
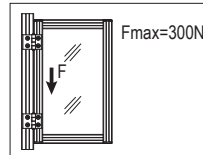
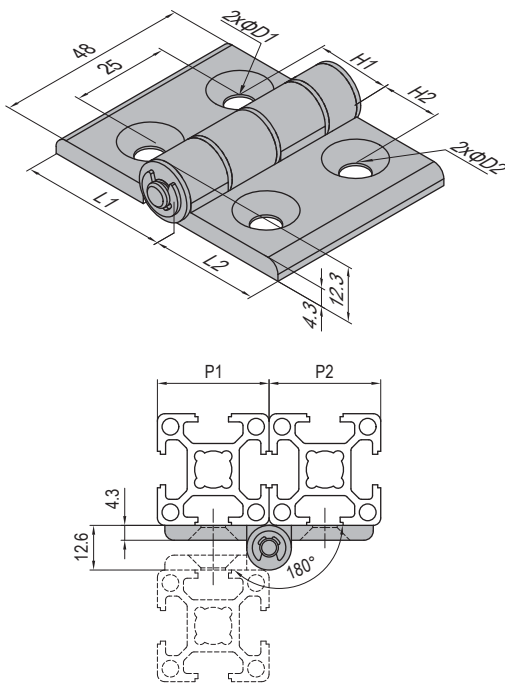

Description	H1 (mm)	H2 (mm)	L1 (mm)	L2 (mm)	D1 (mm)	D2 (mm)	Fastening Set	Mass (g)	Part No.
30/30 (pcs)	15	15	28	28	6.5	6.5		41	7.22.30.30.E
30/30 (set)							4xDJ	65	7.22.30.30.E.ST
30/40 (pcs)	20	15	38	28	6.5	6.5		46	7.22.30.40.E
30/40 (set)							2xDJ+2xFL	80	7.22.30.40.E.ST
30/45 (pcs)	22.5	15	38	28	6.5	6.5		46	7.22.30.45.E
30/45 (set)							2xDJ+2xDL	80	7.22.30.45.E.ST
40/40 (pcs)	20	20	38	38	6.5	6.5		51	7.22.40.40.E
40/40 (set)							4xFL	94	7.22.40.40.E.ST
40/45 (pcs)	22.5	20	38	38	6.5	6.5		51	7.22.40.45.E
40/45 (set)							2xFL+2xDL	95	7.22.40.45.E.ST
45/45 (pcs)	22.5	22.5	38	38	6.5	6.5		51	7.22.45.45.E
45/45 (set)							4xDL	96	7.22.45.45.E.ST

Door and Window Elements

Hinge

Material and Color: aluminum, nature anodized



Hinge-Aluminum Countersink Hole

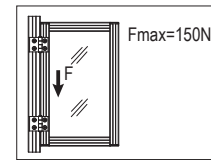
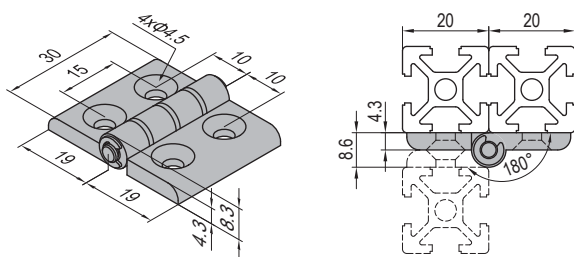

FE	Fastening Set
	M4x8 Bolt zinc plated
	M4 T Nut nickel plated

Description	Fastening Set	Mass (g)	Part No.
20/20 (pcs)		15	7.22.20.20
20/20 (set)	4xFE	25	7.22.20.20.ST

Hinge-Aluminum Countersink Hole

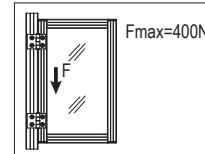
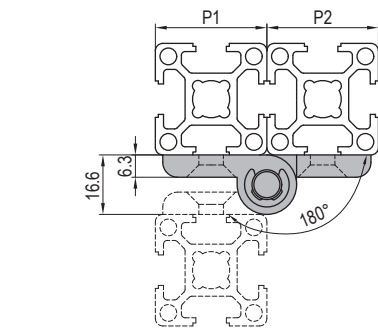
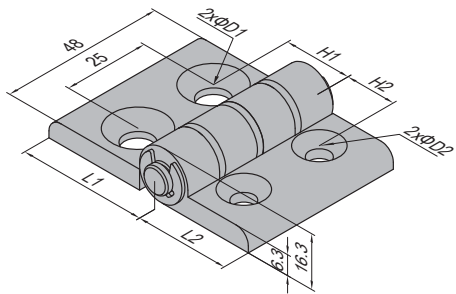

FF	Fastening Set
	M6x12 Bolt zinc plated
	M6 T Nut nickel plated

FG	Fastening Set
	M8x16 Bolt zinc plated
	M8 T Nut nickel plated

Description	H1 (mm)	H2 (mm)	L1 (mm)	L2 (mm)	D1 (mm)	D2 (mm)	Fastening Set	Mass (g)	Part No.
30/30 (pcs)	15	15	28	28	6.5	6.5		69	7.22.30.30
30/30 (set)							4xFF	97	7.22.30.30.ST
30/40 (pcs)	20	15	38	28	8.5	6.5		74	7.22.30.40
30/40 (set)							2xFF+2xFG	122	7.22.30.40.ST
30/45 (pcs)	22.5	15	38	28	8.5	6.5		74	7.22.30.45
30/45 (set)							2xFF+2xFG	122	7.22.30.45.ST
40/40 (pcs)	20	20	38	38	8.5	8.5		81	7.22.40.40
40/40 (set)							4xFG	149	7.22.40.40.ST
40/45 (pcs)	22.5	20	38	38	8.5	8.5		81	7.22.40.45
40/45 (set)							4xFG	149	7.22.40.45.ST
40/50 (pcs)	25	20	43	38	8.5	8.5		84	7.22.40.50
40/50 (set)							4xFG	152	7.22.40.50.ST
45/45 (pcs)	22.5	22.5	38	38	8.5	8.5		81	7.22.45.45
45/45 (set)							4xFG	149	7.22.45.45.ST
45/50 (pcs)	25	22.5	43	38	8.5	8.5		84	7.22.45.50
45/50 (set)							4xFG	152	7.22.45.50.ST
50/50 (pcs)	25	25	43	43	8.5	8.5		84	7.22.50.50
50/50 (set)							4xFG	155	7.22.50.50.ST



Door and Window Elements

Hinge

Material and Color: aluminum, nature anodized



Hinge-Aluminum Through Hole

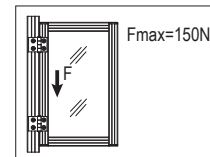
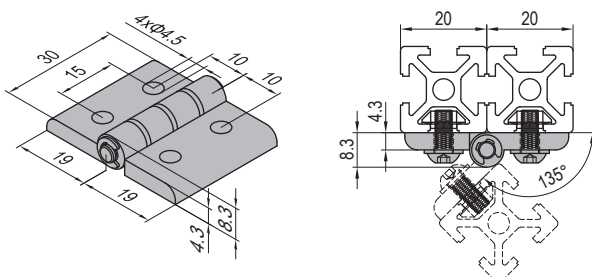

PC Fastening Set	
	M4x10 Bolt zinc plated
	M4 Washer zinc plated
	M4 T Nut nickel plated

Description	Fastening Set	Mass (g)	Part No.
20/20 (pcs)		15	7.23.20.20
20/20 (set)	4xPC	29	7.23.20.20.ST

Hinge-Aluminum Through Hole

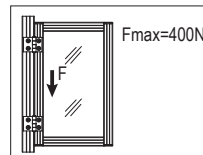
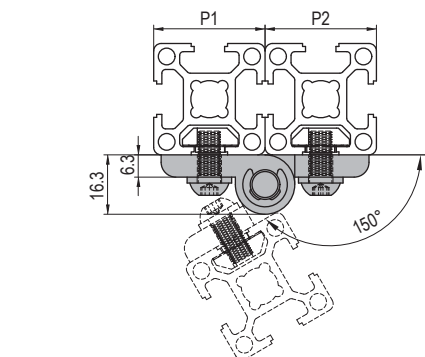
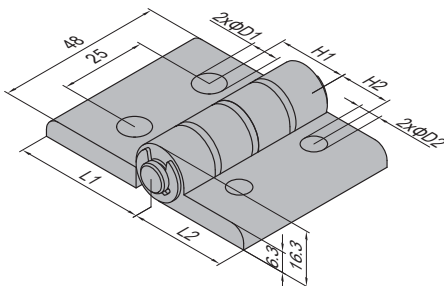

FH Fastening Set	
	M6x14 Bolt zinc plated
	M6 Washer zinc plated
	M6 T Nut nickel plated

FJ Fastening Set	
	M8x16 Bolt zinc plated
	M8 Washer zinc plated
	M8 T Nut nickel plated

FK Fastening Set	
	M8x20 Bolt zinc plated
	M8 Washer zinc plated
	M8 T Nut nickel plated

Description	H1 (mm)	H2 (mm)	L1 (mm)	L2 (mm)	D1 (mm)	D2 (mm)	Fastening Set	Mass (g)	Part No.
30/30 (pcs)	15	15	28	28	6.5	6.5		71	7.23.30.30
30/30 (set)							4xFH	99	7.23.30.30.ST
30/40 (pcs)	20	15	38	28	8.5	6.5		76	7.23.30.40
30/40 (set)							2xFH+2xFJ	124	7.23.30.40.ST
30/45 (pcs)	22.5	15	38	28	8.5	6.5		76	7.23.30.45
30/45 (set)							2xFH+2xFK	127	7.23.30.45.ST
40/40 (pcs)	20	20	38	38	8.5	8.5		83	7.23.40.40
40/40 (set)							4xFJ	151	7.23.40.40.ST
40/45 (pcs)	22.5	20	38	38	8.5	8.5		83	7.23.40.45
40/45 (set)							2xFJ+2xFK	156	7.23.40.45.ST
40/50 (pcs)	25	20	43	38	8.5	8.5		87	7.23.40.50
40/50 (set)							2xFJ+2xFK	159	7.23.40.50.ST
45/45 (pcs)	22.5	22.5	38	38	8.5	8.5		83	7.23.45.45
45/45 (set)							4xFK	161	7.23.45.45.ST
45/50 (pcs)	25	22.5	43	38	8.5	8.5		87	7.23.45.50
45/50 (set)							4xFK	167	7.23.45.50.ST
50/50 (pcs)	25	25	43	43	8.5	8.5		87	7.23.50.50
50/50 (set)							4xFK	164	7.23.50.50.ST



Door and Window Elements

Hinge

Material and Color: aluminum, nature anodized



Hinge-Aluminum Countersink Hole

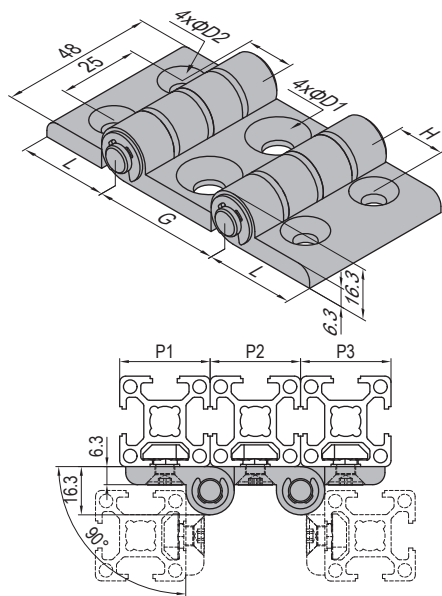

Hinge-Aluminum Through Hole

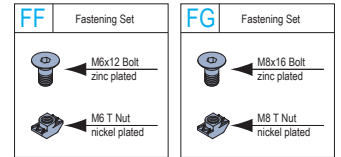
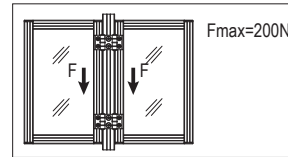
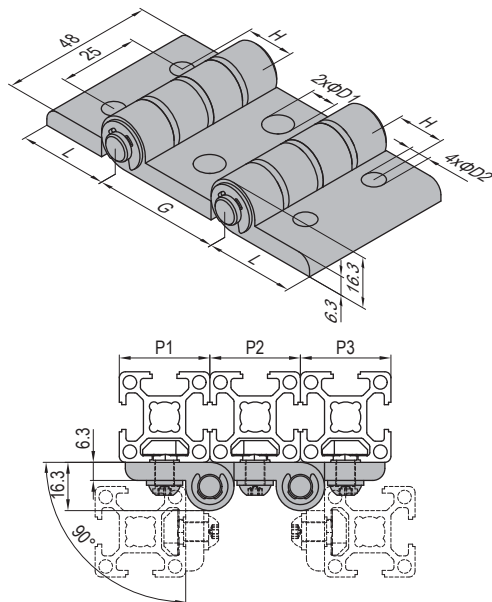

Description	G (mm)	H (mm)	L (mm)	D1 (mm)	D2 (mm)	Fastening Set	Mass (g)	Part No.
30/30/30 (pcs)	30	15	28	6.5	6.5		98	7.24.30.30.30
30/30/30 (set)						6xFF	140	7.24.30.30.30.ST
30/40/30 (pcs)	40	15	28	8.5	6.5		104	7.24.30.40.30
30/40/30 (set)						4xFF+2xFG	166	7.24.30.40.30.ST
30/45/30 (pcs)	45	15	28	8.5	6.5		108	7.24.30.45.30
30/45/30 (set)						4xFF+2xFG	170	7.24.30.45.30.ST
40/40/40 (pcs)	40	20	38	8.5	8.5		115	7.24.40.40.40
40/40/40 (set)						6xFG	217	7.24.40.40.40.ST
40/45/40 (pcs)	45	20	38	8.5	8.5		119	7.24.40.45.40
40/45/40 (set)						6xFG	221	7.24.40.45.40.ST
45/45/45 (pcs)	45	22.5	38	8.5	8.5		119	7.24.45.45.45
45/45/45 (set)						6xFG	221	7.24.45.45.45.ST

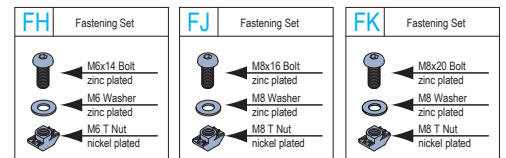
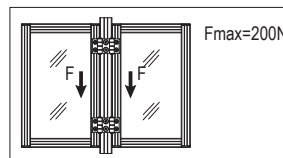

Description	G (mm)	H (mm)	L (mm)	D1 (mm)	D2 (mm)	Fastening Set	Mass (g)	Part No.
30/30/30 (pcs)	30	15	28	6.5	6.5		100	7.25.30.30.30
30/30/30 (set)						6xFH	142	7.25.30.30.30.ST
30/40/30 (pcs)	40	15	28	8.5	6.5		107	7.25.30.40.30
30/40/30 (set)						4xFH+2xFJ	169	7.25.30.40.30.ST
30/45/30 (pcs)	45	15	28	8.5	6.5		111	7.25.30.45.30
30/45/30 (set)						4xFH+2xFK	175	7.25.30.45.30.ST
40/40/40 (pcs)	40	20	38	8.5	8.5		121	7.25.40.40.40
40/40/40 (set)						6xFJ	213	7.25.40.40.40.ST
40/45/40 (pcs)	45	20	38	8.5	8.5		125	7.25.40.45.40
40/45/40 (set)						4xFJ+2xFK	230	7.25.40.45.40.ST
45/45/45 (pcs)	45	22.5	38	8.5	8.5		125	7.25.45.45.45
45/45/45 (set)						6xFK	245	7.25.45.45.45.ST



Door and Window Elements

Hinge

Material and Color: aluminum, nature anodized

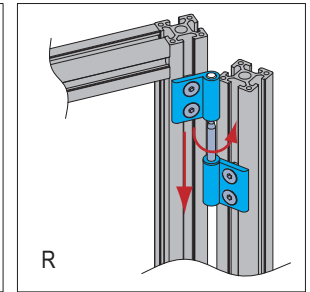
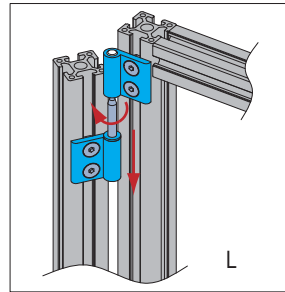

Hinge-AI Removable Hinge-L

Hinge-AI Removable Hinge-R

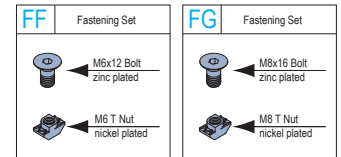
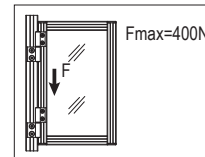
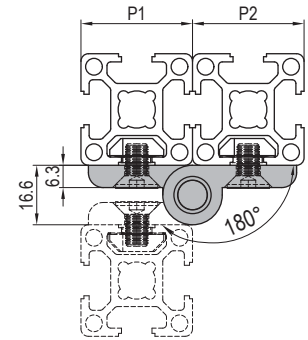
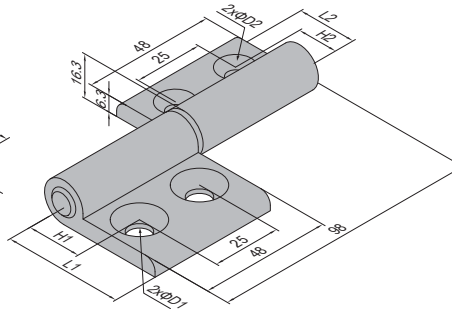
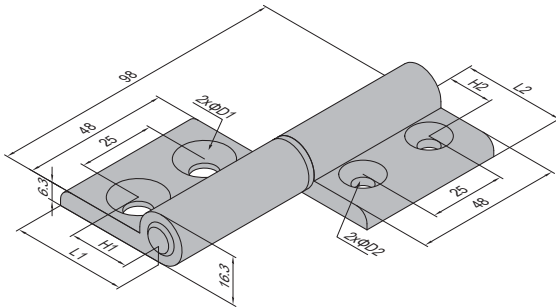

Description	H1 (mm)	H2 (mm)	L1 (mm)	L2 (mm)	D1 (mm)	D2 (mm)	Fastening Set	Mass (g)	Part No.(L)	Part No.(R)
30/30 (pcs)	15	15	28	28	6.5	6.5		105	7.26.30.30	7.27.30.30
30/30 (set)							4xFF	133	7.26.30.30.ST	7.27.30.30.ST
30/40 (pcs)	20	15	38	28	8.5	6.5		110	7.26.30.40	7.27.30.40
30/40 (set)							2xFF+2xFG	158	7.26.30.40.ST	7.27.30.40.ST
30/45 (pcs)	22.5	15	38	28	8.5	6.5		110	7.26.30.45	7.27.30.45
30/45 (set)							2xFF+2xFG	158	7.26.30.45.ST	7.27.30.45.ST
40/40 (pcs)	20	20	38	38	8.5	8.5		118	7.26.40.40	7.27.40.40
40/40 (set)							4xFG	186	7.26.40.40.ST	7.27.40.40.ST
40/45 (pcs)	22.5	20	38	38	8.5	8.5		118	7.26.40.45	7.27.40.45
40/45 (set)							4xFG	186	7.26.40.45.ST	7.27.40.45.ST
40/50 (pcs)	25	20	43	38	8.5	8.5		121	7.26.40.50	7.27.40.50
40/50 (set)							4xFG	189	7.26.40.50.ST	7.27.40.50.ST
45/45 (pcs)	22.5	22.5	38	38	8.5	8.5		118	7.26.45.45	7.27.45.45
45/45 (set)							4xFG	186	7.26.45.45.ST	7.27.45.45.ST
45/50 (pcs)	25	22.5	43	38	8.5	8.5		121	7.26.45.50	7.27.45.50
45/50 (set)							4xFG	189	7.26.45.50.ST	7.27.45.50.ST
50/50 (pcs)	25	25	43	43	8.5	8.5		121	7.26.50.50	7.27.50.50
50/50 (set)							4xFG	192	7.26.50.50.ST	7.27.50.50.ST



Door and Window Elements

Hinge

Material and Color: aluminum, nature anodized



Hinge-Long Aluminum Hinge

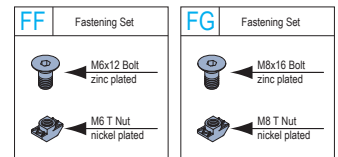
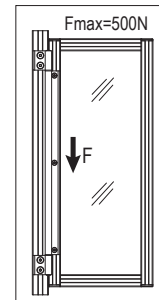
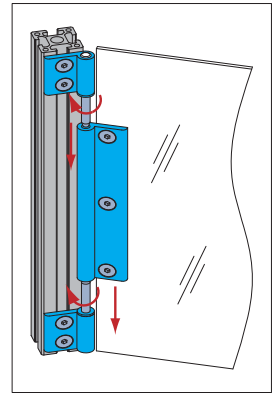
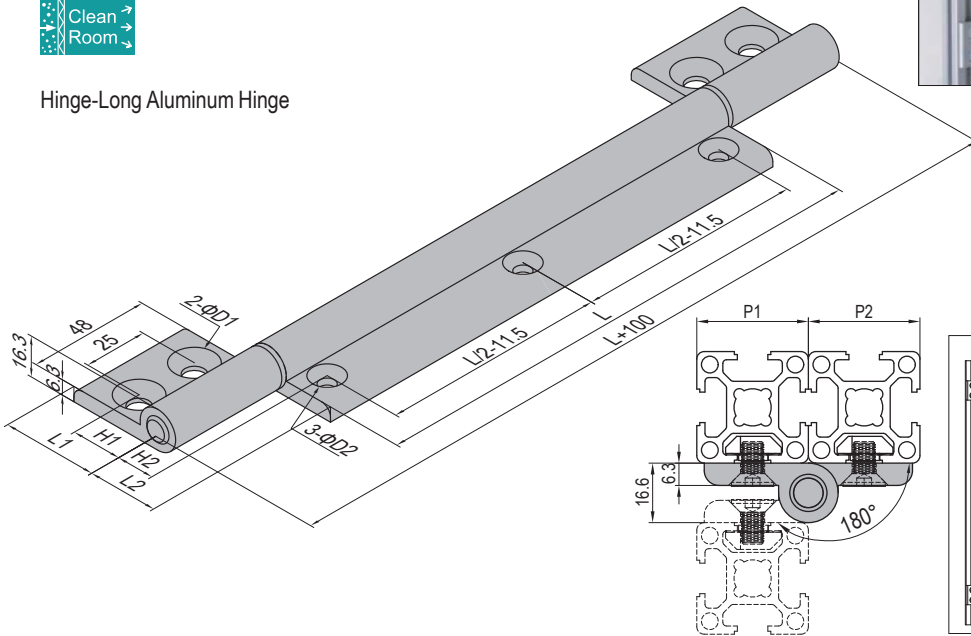

Description	H1 (mm)	H2 (mm)	L1 (mm)	L2 (mm)	D1 (mm)	D2 (mm)	L (mm)	Fastening Set	Mass (g)	Part No.
30/30 (pcs)	15	15	28	28	6.5	6.5	500		515	7.28.30.30
30/30 (set)								7×FF	571	7.28.30.30.ST
30/40 (pcs)	20	15	38	28	8.5	6.5			525	7.28.30.40
30/40 (set)								3×FF+4×FG	617	7.28.30.40.ST
30/45 (pcs)	22.5	15	38	28	8.5	6.5			525	7.28.30.45
30/45 (set)								3×FF+4×FG	617	7.28.30.45.ST
40/40 (pcs)	20	20	38	38	8.5	8.5			605	7.28.40.40
40/40 (set)								7×FG	724	7.28.40.40.ST
40/45 (pcs)	22.5	20	38	38	8.5	8.5			605	7.28.40.45
40/45 (set)								7×FG	724	7.28.40.45.ST
45/45 (pcs)	22.5	22.5	38	38	8.5	8.5		605	7.28.45.45	
45/45 (set)							7×FG	724	7.28.45.45.ST	

Note: The length could be customized according to customer's requirements (100~1000mm).

ex: 7.28.30.30 - 1000







Door and Window Elements

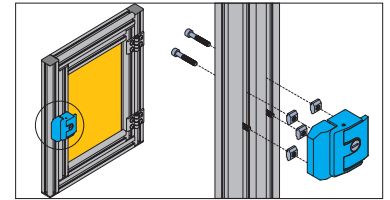

Compact metal lock with self-locking design.

Material and Color: diecast zinc, black electrophoresis



EL	Fastening Set	EM	Fastening Set	EN	Fastening Set
	M6x30 Bolt zinc plated		M6x40 Bolt zinc plated		M6x45 Bolt zinc plated

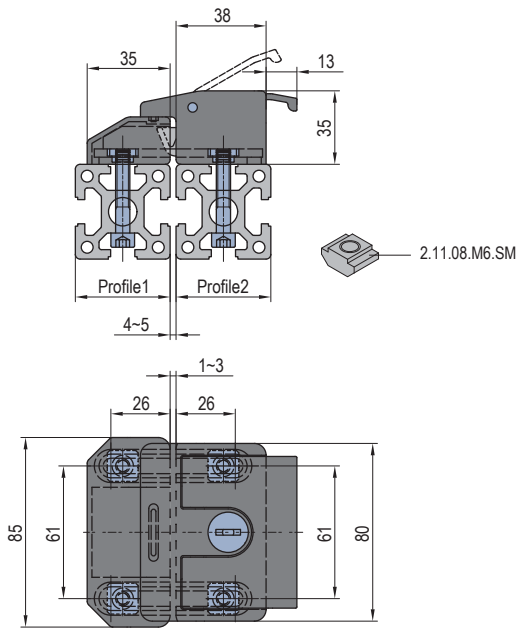

Description	Profile 1	Profile 2	Fastening Set	Mass (g)	Part No.
Lock (pcs)				690	7.31
Lock-3030 (set)	PG30 30系列	PG30 30系列	4xEL	719	7.31.30.30
Lock-4030 (set)	PG40 40系列	PG30 30系列	2xEL 2xEM	724	7.31.40.30
Lock-4040 (set)	PG40 40系列	PG40 40系列	4xEM	728	7.31.40.40
Lock-4530 (set)	PG45 45系列	PG30 30系列	2xEL 2xEN	726	7.31.45.30
Lock-4540 (set)	PG45 45系列	PG40 40系列	2xEM 2xEN	731	7.31.45.40
Lock-4545 (set)	PG45 45系列	PG45 45系列	4xEN	733	7.31.45.45

Note: Including special nuts.

Door and Window Elements



Lock

Material and Color: zinc alloy, polish finish



L Lock

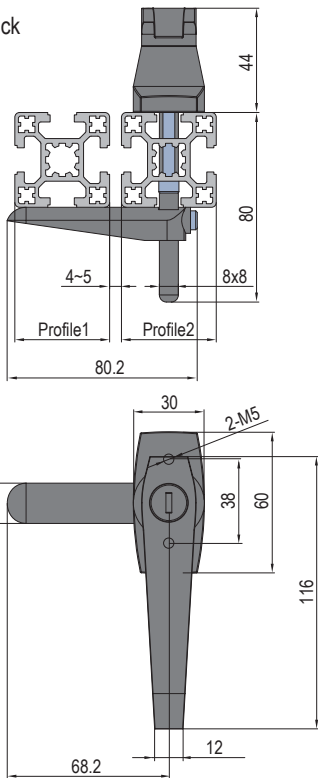

T Lock

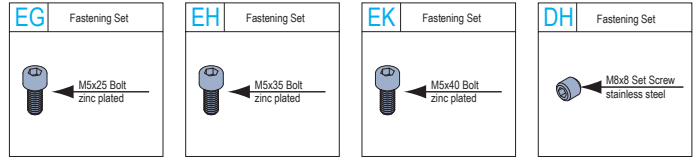
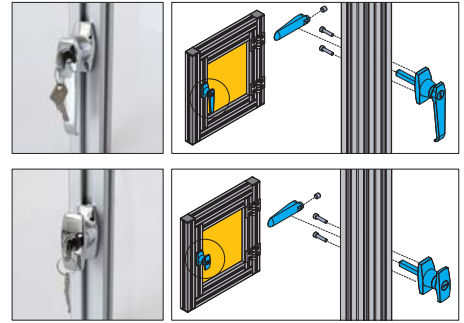
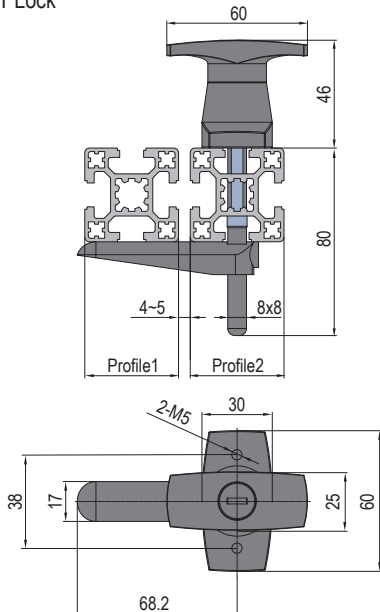

Description	Profile 1	Profile 2	Fastening Set	Mass (g)	Part No.
L Lock-3030	PG30	PG30	DH+2xEG	290	7.32.30.30
L Lock-4030	PG40	PG30			7.32.40.30
L Lock-4530	PG45	PG30			7.32.45.30
L Lock-4040	PG40	PG40	DH+2xEH	294	7.32.40.40
L Lock-4540	PG45	PG40			7.32.45.40
L Lock-5040	PG50	PG40			7.32.50.40
L Lock-4545	PG45	PG45	DH+2xEK	296	7.32.45.45
L Lock-5045	PG50	PG45			7.32.50.45
L Lock-5050	PG50	PG50			7.32.50.50
T Lock-3030	PG30	PG30	DH+2xEG	270	7.33.30.30
T Lock-4030	PG40	PG30			7.33.40.30
T Lock-4530	PG45	PG30			7.33.45.30
T Lock-4040	PG40	PG40	DH+2xEH	274	7.33.40.40
T Lock-4540	PG45	PG40			7.33.45.40
T Lock-5040	PG50	PG40			7.33.50.40
T Lock-4545	PG45	PG45	DH+2xEK	276	7.33.45.45
T Lock-5045	PG50	PG45			7.33.50.45
T Lock-5050	PG50	PG50			7.33.50.50



Door and Window Elements

Magnet Catch

Material: Magnet Catch-aluminum alloy, hard oxidation anodized
Connectors-zinc plated steel

Note: When the magnet catch is installed on the lower door frame, the door should be more than 400mm. .

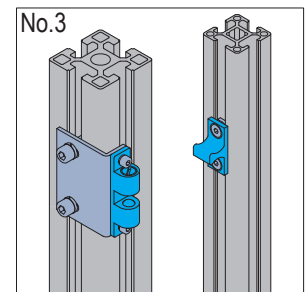
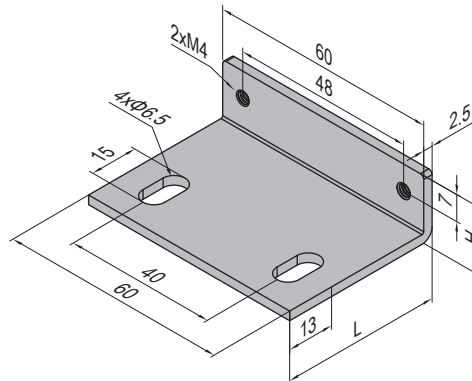
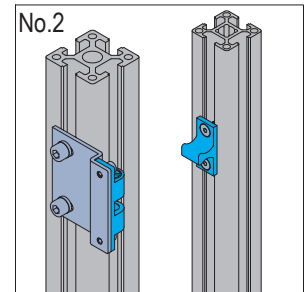
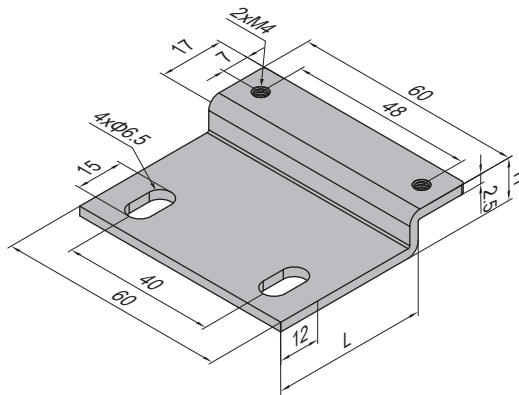
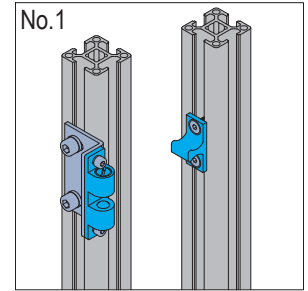
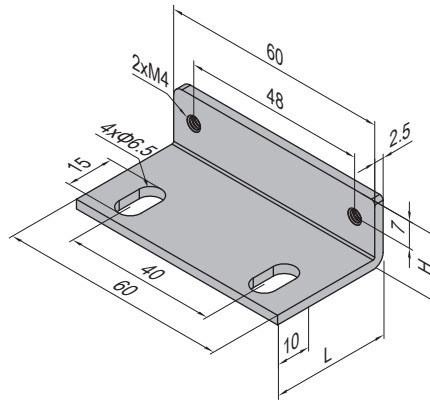
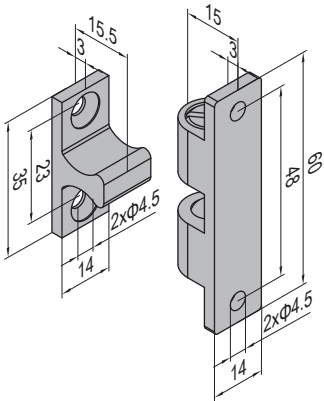

CF Fastening Set M4x10 Bolt zinc plated M4 T Nut nickel plated	PF Fastening Set M4x8 Bolt zinc plated M4 Spring Washer zinc plated M4 Washer zinc plated	CJ Fastening Set M6x10 Bolt zinc plated M6 Spring Washer zinc plated M6 T Nut nickel plated	CK Fastening Set M6x14 Bolt zinc plated M6 Spring Washer zinc plated M6 T Nut nickel plated	CN Fastening Set M6x16 Bolt zinc plated M6 Spring Washer zinc plated M6 T Nut nickel plated
---	---	---	---	---

Description	L (mm)	H (mm)	Fastening Set	Mass (g)	Part No.
Magnet Catch-14 (pcs)				26	7.41.14
Magnet Catch-14 (Profile 3030 for Door, Profile 3030 for Doorframe set No.1)	31	17	2xCF+2xPF+2xCJ	130	7.41.14.3030.ST
Magnet Catch-14 (Profile 3030 for Door, Profile 4040 for Doorframe set No.2)	41	11	2xCF+2xPF+2xCK	139	7.41.14.3040.ST
Magnet Catch-14 (Profile 3030 for Door, Profile 4545 for Doorframe set No.3)	42	14	2xCF+2xPF+2xCN	145	7.41.14.3045.ST



Door and Window Elements

Magnet Catch

Material: Magnet Catch-aluminum alloy, hard oxidation anodized

Connector-zinc plated steel
(Material for Connector 4080 is aluminum alloy)

Note: When the magnet catch is installed on the lower door frame, the door should be more than 400mm.

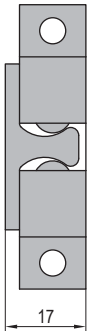
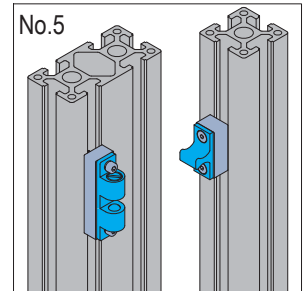
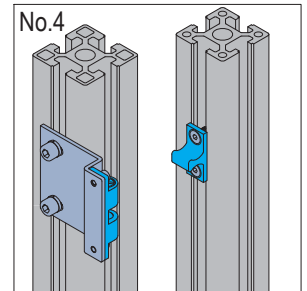
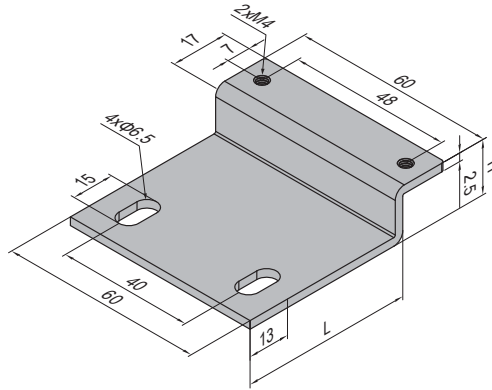

Tighten Status 1

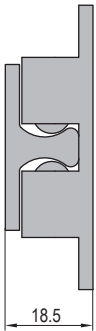

Tighten Status 2

CG	Fastening Set	PF	Fastening Set	CK	Fastening Set	CL	Fastening Set	CY	Fastening Set	CN	Fastening Set
	M4x14 Bolt zinc plated		M4x8 Bolt zinc plated		M6x14 Bolt zinc plated		M4x25 Bolt zinc plated		M4x20 Bolt zinc plated		M6x16 Bolt zinc plated
	M4 Spring Washer zinc plated		M4 Spring Washer zinc plated		M5 Spring Washer zinc plated		M4 Spring Washer zinc plated		M4 Spring Washer zinc plated		M6 Spring Washer zinc plated
	M4 T Nut nickel plated		M4 Washer zinc plated		M6 T Nut nickel plated		M4 T Nut nickel plated		M4 T Nut nickel plated		M6 T Nut nickel plated

Description	L (mm)	H (mm)	Fastening Set	Mass (g)	Part No.
Magnet Catch-14 (Profile 4040 for Door, Profile 4040 for Doorframe set No.1)	45	17	2xCG+2xPF+2xCK	147	7.41.14.4040.ST
Magnet Catch-14 (Profile 4040 for Door, Profile 4545 for Doorframe set No.4)	51	16	2xCG+2xPF+2xCN	151	7.41.14.4045.ST
Magnet Catch-14 (Profile 4040 for Door, Profile 4080 for Doorframe set No.5)			2xCL+2xCY	255	7.41.14.4080.ST
Magnet Catch-14 (Profile 4040 for Door, Profile 5050 for Doorframe set No.4)	51	11	2xCG+2xPF+2xCN	145.5	7.41.14.4050.ST
Magnet Catch-14 (Profile 4545 for Door, Profile 4545 for Doorframe set No.1)	45	17	2xCG+2xPF+2xCN	151	7.41.14.4545.ST
Magnet Catch-14 (Profile 4545 for Door, Profile 5050 for Doorframe set No.4)	51	16	2xCG+2xPF+2xCN	151	7.41.14.4550.ST
Magnet Catch-14 (Profile 5050 for Door, Profile 5050 for Doorframe set No.1)	50	17	2xCG+2xPF+2xCN	149	7.41.14.5050.ST



Door and Window Elements

Door lock

Material: DoorLock-black electrophoresis
Block-diecast aluminum, black electrophoresis

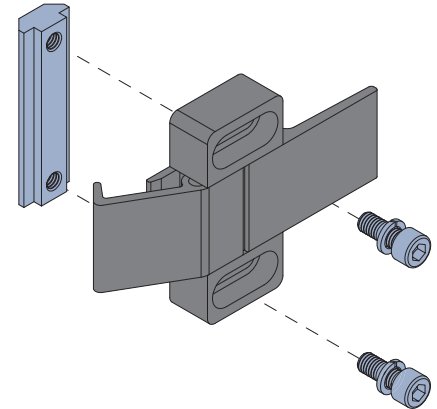
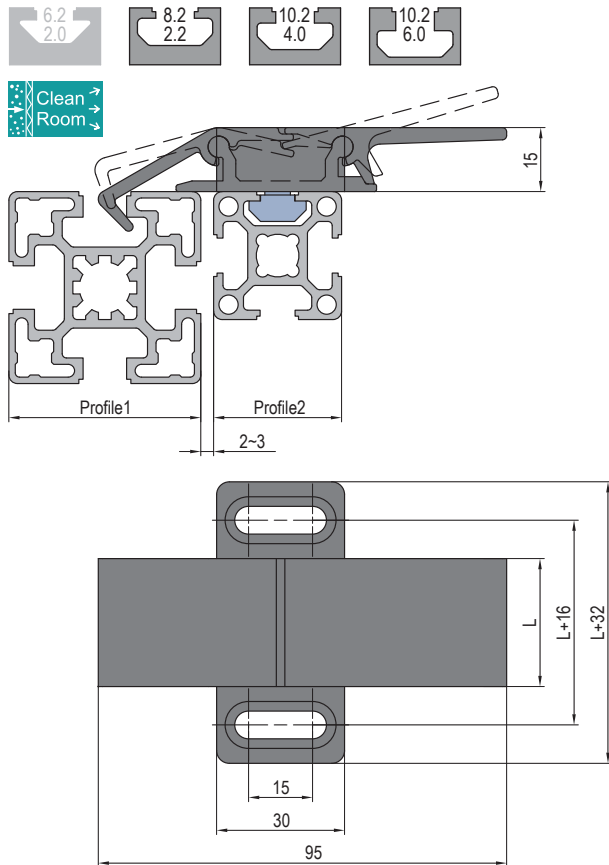

Description	Profile 1	Profile 2	L (mm)	Fastening Set	Mass (g)	Part No.
Door Locks-3040	PG40	PG30	30	2xCU+1xEP	115	7.42.30.3040
Door Locks-3045	PG45	PG30			115	7.42.30.3045
Door Locks-4040	PG40	PG40			140	7.42.30.4040
Door Locks-4045	PG45	PG40	50	2xCU+1xEP	185	7.42.30.4045
Door Locks-4545	PG45	PG45	50	2xCV+1xEP	187	7.42.30.4545

CU Fastening Set

- M6x16 Bolt zinc plated
- M6 Spring Washer zinc plated

CV Fastening Set

- M6x20 Bolt zinc plated
- M6 Spring Washer zinc plated

EP Fastening Set

- Special nut

Note: including block and special nut.

2 The length could be customized according to customer's requirement(30~80mm)

ex: 7.42.30.3040 - 50
 L=50mm
 Part No.



Door and Window Elements

Sliding Door Profile

The sliding door profile clips into strut profiles and is suitable for light-weight sliding doors.

Material and Colors: Sliding door profile-PVC, grey PE Bar-HD-PE, Nature.

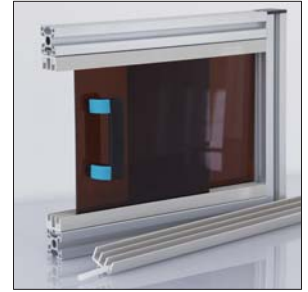

Sliding Door Profile-8

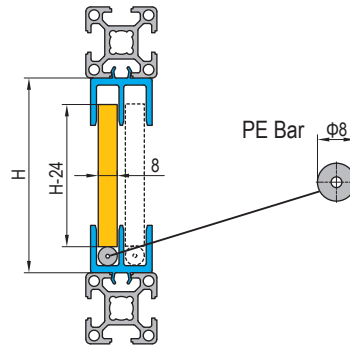
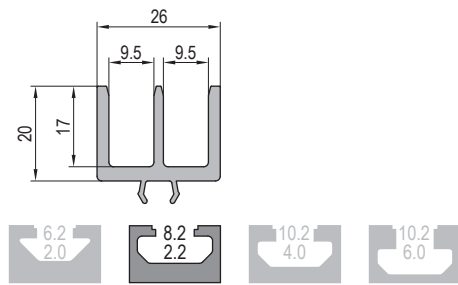

Sliding Door Profile-10-4

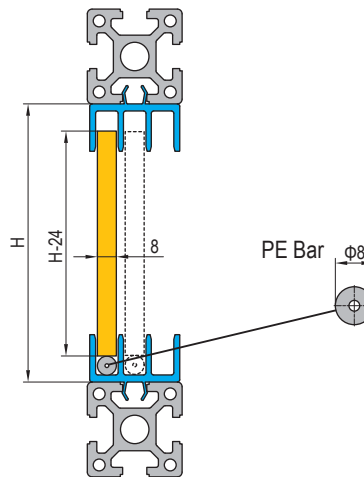
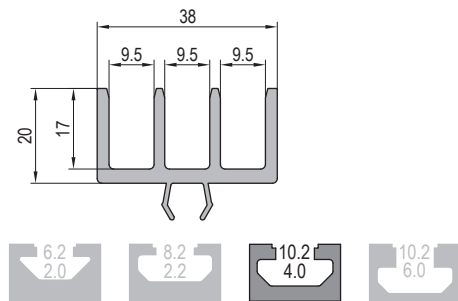

Description	PG	Mass (g/m)	Delivery Length	Part No.
Sliding Door Profile-8	PG30	330	3000mm/bar	7.51.08
Sliding Door Profile-8 (Including 2 pcs PE bar)		390		7.51.08.ST
Sliding Door Profile-10-4	PG40	450		7.51.10.04
Sliding Door Profile-10-4 (Including 2 pcs PE bar)		510		7.51.10.04.02.ST
Sliding Door Profile-10-4 (Including 3 pcs PE bar)		540		7.51.10.04.03.ST





8.11-8.61

- Suspended Glider
- Swivel Angle Plate
- Potential Equaliser Nut
- Joint
- Frame Joint
- Mounting Adaptor for Roller
- Telescope Unit

8

Additional Accessories



P. 8-02



P. 8-03



P. 8-04



P. 8-05



P. 8-07



P. 8-08



P. 8-09



Additional Accessories

Suspended Glider

The glider can be suspended in profile slot.

Material and Color: glider-PA6+GF30, black hook-zinc plated steel

Suspended Glider-8

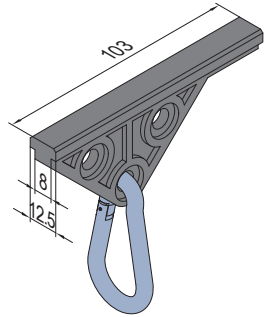
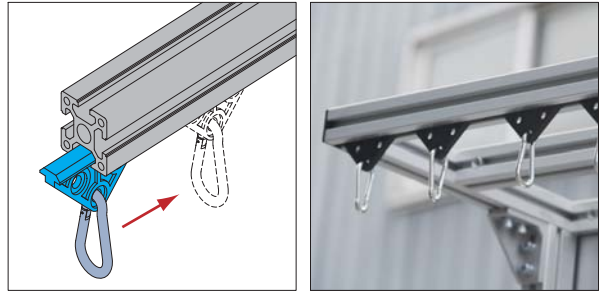

Description	Static Load (N)	Mass (g)	Part No.
Suspended Glider-8	200	48	8.11.08

Suspended Glider -10

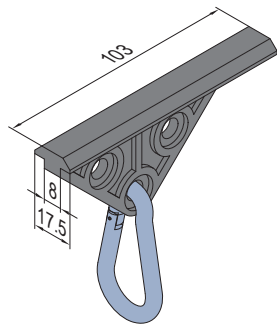

Description	Static Load (N)	Mass (g)	Part No.
Suspended Glider-10	200	48	8.11.10

Additional Accessories

Swivel Angle Plate

Infinitely variable adjusting of inclination with swivel angle.

Material and Color: steel, black electrophoresis

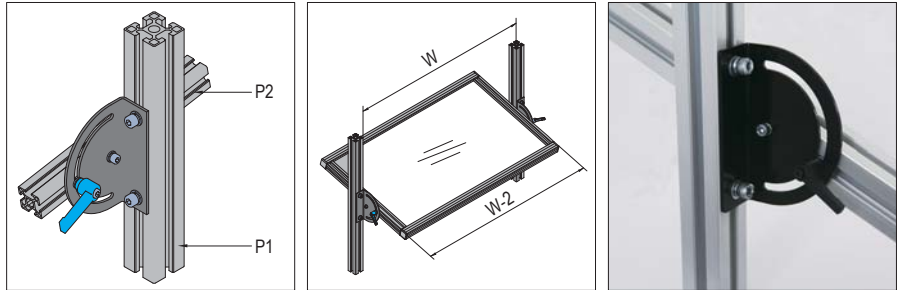

Swivel Angle Plate-PG30

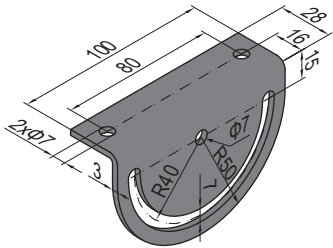

Swivel Angle Plate-PG40/45

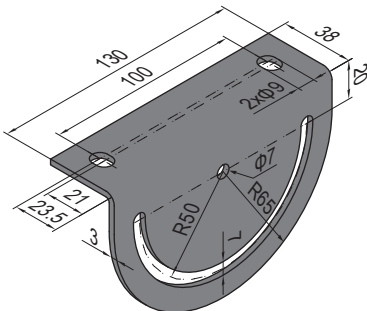

FR	FT	FV	FW	R
Fastening Set	Fastening Set	Fastening Set	Fastening Set	Fastening Set
M6x12 Adjustable Handle plastic coated, black	M6x12 Bolt zinc plated	M8x16 Bolt zinc plated	M6x16 Bolt zinc plated	M6x12 Bolt zinc plated
M6 Washer zinc plated	M6 Washer zinc plated	M8 Washer zinc plated	M6 Washer zinc plated	M6 Washer zinc plated
M6 Pre-set Nut nickel plated	M6 Pre-set Nut nickel plated	M8 T Nut nickel plated	M6 Pre-set Nut nickel plated	M6 T Nut nickel plated

Description	P1	P2	Fastening Set	Mass (g)	Part No.
Swivel Angle Plate-PG30 (pcs)				160	8.21.30
Swivel Angle Plate-PG30 (set)	PG30	PG30	1xFR+1xFT+2xR	270	8.21.30.ST
Swivel Angle Plate-PG40/45 (pcs)				288	8.21.40
Swivel Angle Plate-PG40/45-PG30 (set)	PG40/45	PG30	1xFR+1xFT+2xFV	420	8.21.40.30.ST
Swivel Angle Plate-PG40/45-PG40/45 (set)	PG40/45	PG40/45	1xFR+2xFV+1xFW	443	8.21.40.40.ST

Additional Accessories

Potential Equaliser Nut

Potential Equaliser Nut penetrates the oxide film of the profiles at the connection to conduct the static inside of the profiles and to average the potential.

Material: zinc alloy

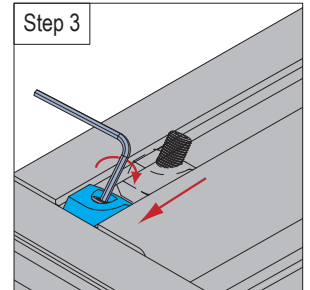
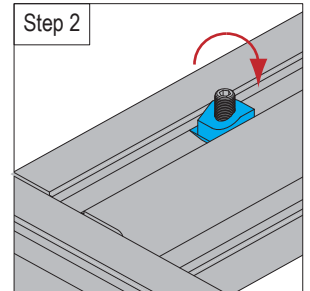
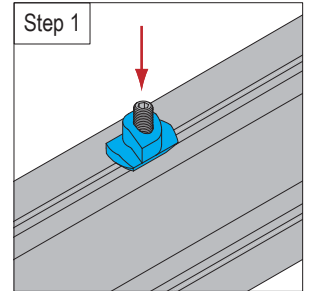
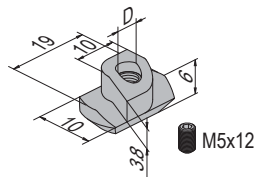
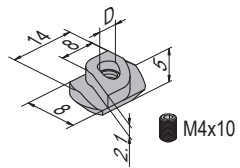
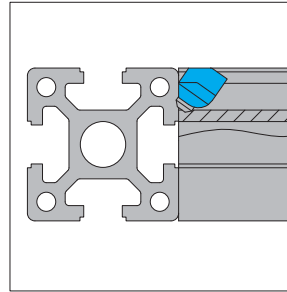

Description	D	Mass (g/pcs)	Part No.
Potential Equaliser Nut-8-M4 (with top thread)	M4	3	8.22.08.M4
Potential Equaliser Nut-10-M5 (with top thread)	M5	7	8.22.10.M5

Additional Accessories



Joint

To connect movable profiles.

Material: zinc plated steel



Joint-Type A

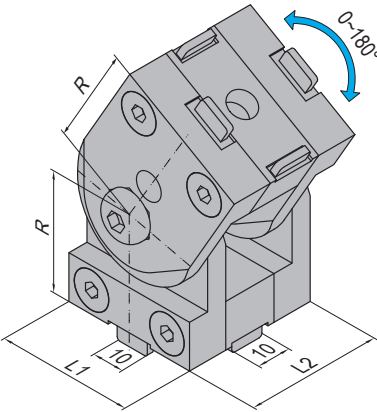



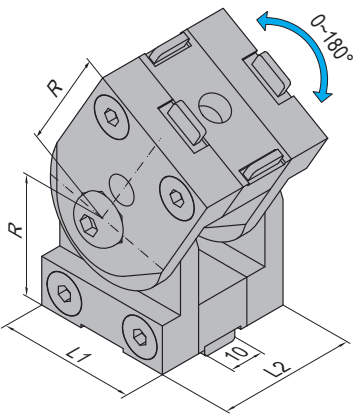

Joint-Type B

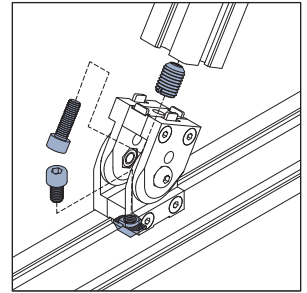
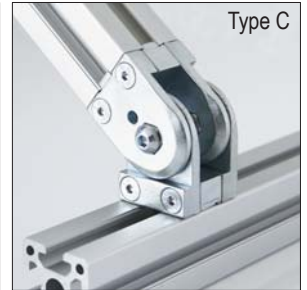
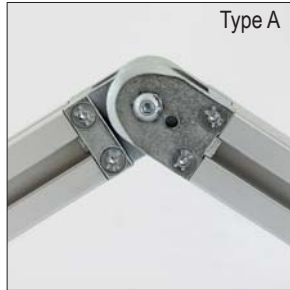
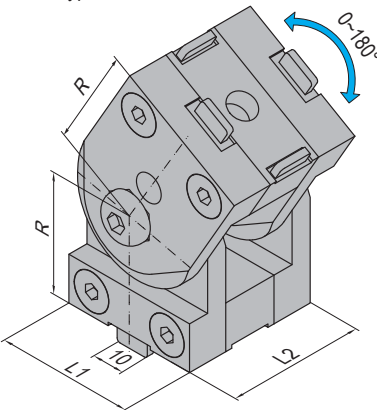

Joint-Type C



FD	Fastening Set	FX	Fastening Set
	M8x16 Bolt zinc plated		M8x20 Bolt zinc plated
	M8 T Nut nickel plated		M14-M8 Hole Reducer Bolt nickel plated

Description	L1 (mm)	L2 (mm)	R (mm)	Fastening Set	Mass (g)	Part No.
Joint-Type A-4040	40	40	35	2xFX	560	8.31.4040A
Joint-Type A-4060		60			680	8.31.4060A
Joint-Type A-4545	45	45	37.5	2xFX	650	8.31.4545A
Joint-Type A-4560		60			800	8.31.4560A
Joint-Type B-4040	40	40	35	1xFD+1xFX	575	8.31.4040B
Joint-Type B-4060		60			695	8.31.4060B
Joint-Type B-4545	45	45	37.5	1xFD+1xFX	665	8.31.4545B
Joint-Type B-4560		60			815	8.31.4560B
Joint-Type C-4040	40	40	35	1xFD+1xFX	575	8.31.4040C
Joint-Type C-4060		60			695	8.31.4060C
Joint-Type C-4545	45	45	37.5	1xFD+1xFX	665	8.31.4545C
Joint-Type C-4560		60			815	8.31.4560C

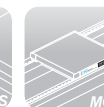

Additional Accessories



To connect movable profiles.

Material: zinc alloy



Joint-Type A

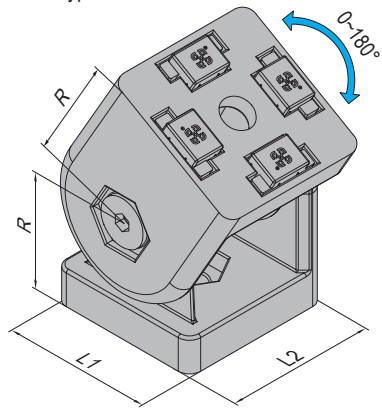



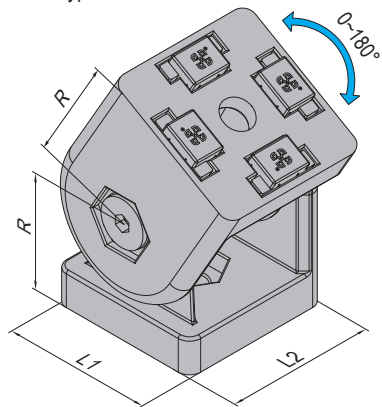



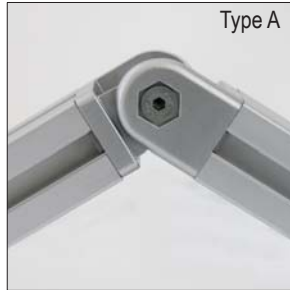
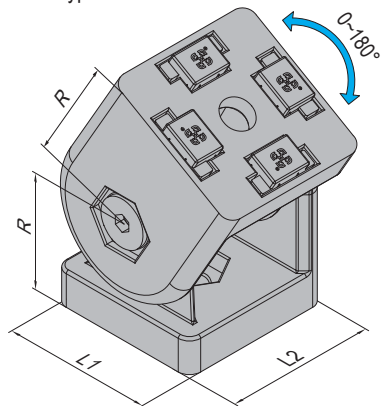



Joint-Type B



Joint-Type C



Note: Ratchet handle (part number RH) is an optional accessory for all three connection types-type A, B and C.

FS	FO	FU	FX	GO
Fastening Set	Fastening Set	Fastening Set	Fastening Set	Fastening Set
 M6x10 Bolt zinc plated	 M6x16 Bolt zinc plated	 M6x12 Bolt zinc plated	 M8x20 Bolt zinc plated	 M8x16 Bolt zinc plated
 M6 T Nut nickel plated	 M12-M6 Hole Reducer Bolt nickel plated	 M8 T Nut nickel plated	 M14-M8 Hole Reducer Bolt nickel plated	 M8 T Nut nickel plated

Description	L1 (mm)	L2 (mm)	R (mm)	Fastening Set	Mass (g)	Part No.
Joint-Type A-3030	30	30	22.5	2xFO	181	8.32.3030A
Joint-Type A-3030-RH					211	8.32.3030A.RH
Joint-Type A-4040	40	40	30	2xFX	388	8.32.4040A
Joint-Type A-4040-RH					447	8.32.4040A.RH
Joint-Type A-4545	45	45	33.5	2xFX	530	8.32.4545A New!
Joint-Type A-4545-RH					587	8.32.4545A.RH New!
Joint-Type B-3030	30	30	22.5	1xFS+1xFO	167	8.32.3030B
Joint-Type B-3030-RH					206	8.32.3030B.RH
Joint-Type B-4040	40	40	30	1xFU+1xFX	366	8.32.4040B
Joint-Type B-4040-RH					437	8.32.4040B.RH
Joint-Type B-4545	45	45	33.5	1xFX+1xGO	510	8.32.4545B New!
Joint-Type B-4545-RH					577	8.32.4545B.RH New!

Additional Accessories



To connect movable profiles.

Material: zinc alloy



Joint-Type A

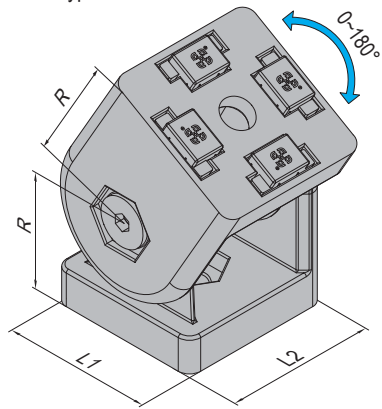

Joint-Type B

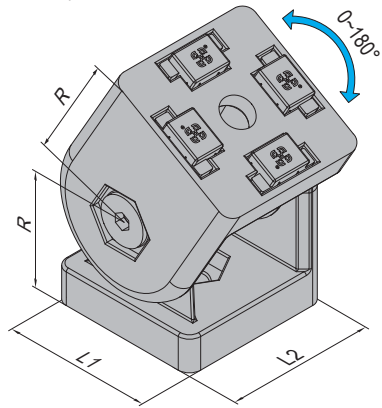

Joint-Type C

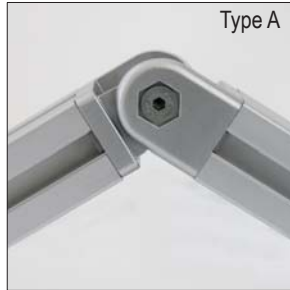
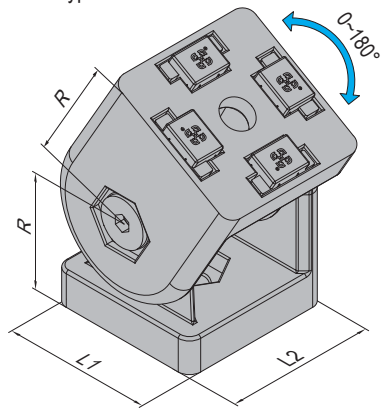

Note: Ratchet handle (part number RH) is an optional accessory for all three connection types-type A, B and C.

FS	FO	FU	FX	GO
Fastening Set	Fastening Set	Fastening Set	Fastening Set	Fastening Set
M6x10 Bolt zinc plated	M6x16 Bolt zinc plated	M8x12 Bolt zinc plated	M8x20 Bolt zinc plated	M8x16 Bolt zinc plated
M6 T Nut nickel plated	M12→M6 Hole Reducer Bolt nickel plated	M8 T Nut nickel plated	M14→M8 Hole Reducer Bolt nickel plated	M8 T Nut nickel plated

Description	L1 (mm)	L2 (mm)	R (mm)	Fastening Set	Mass (g)	Part No.
Joint-Type C-3030	30	30	22.5	1xFS+1xFO	167	8.32.3030C
Joint-Type C-3030-RH					206	8.32.3030C.RH
Joint-Type C-4040	40	40	30	1xFU+1xFX	366	8.32.4040C
Joint-Type C-4040-RH					437	8.32.4040C.RH
Joint-Type C-4545	45	45	33.5	1xFX+1xGO	510	8.32.4545C New!
Joint-Type C-4545-RH					577	8.32.4545C.RH New!



Additional Accessories



When the profile frame is with big span and there is slight bending caused by self load, the frame joint shall be used with special connectors for cross connection to enhance the stability of the frame.

Material: aluminium, anodized (cutting end not anodized).

End cap: black ABS

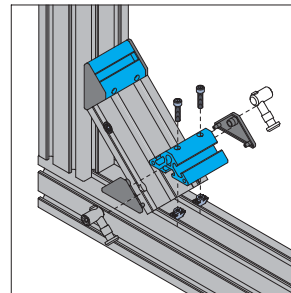
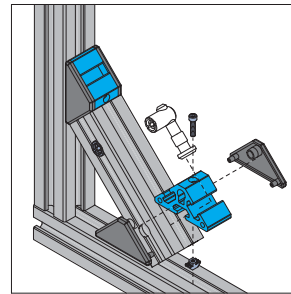
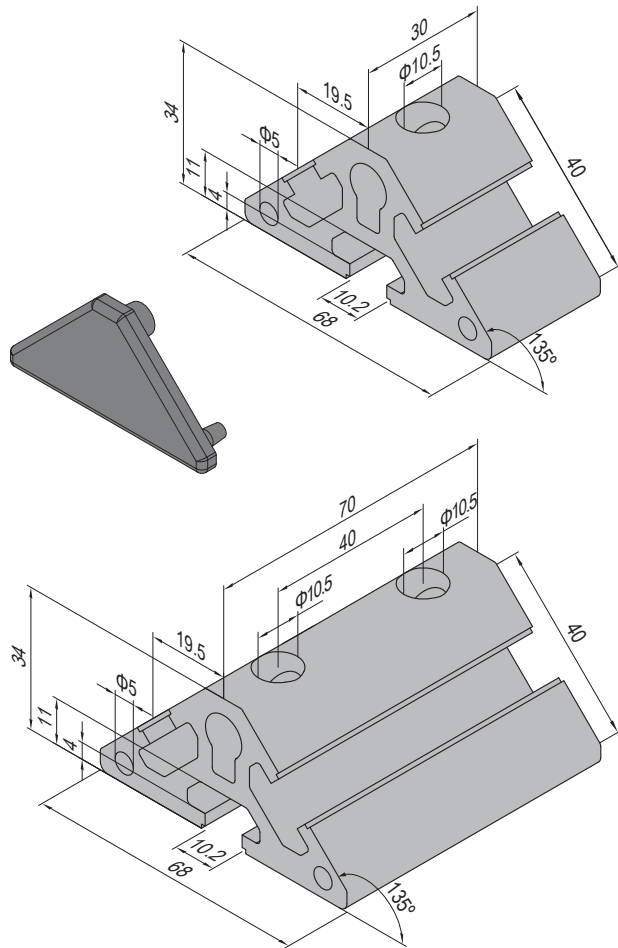

Description	Fastening Set	End Cap	Mass (g)	Part No.
PG40-4040	1xCB	2	95	8.41.4040
PG40-4080	2xCB		192	8.41.4080

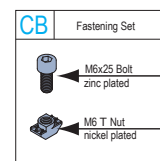

Note: Anchor Connector to be ordered separately refer to P. 3-03 for more detail.



Additional Accessories

Mounting Adaptor for Roller

Special connector for quick roller installation.

Material: Adaptor-steel, zinc plated End cap: black PA6



Mounting Adaptor for Roller-A

End Cap

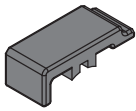

Left

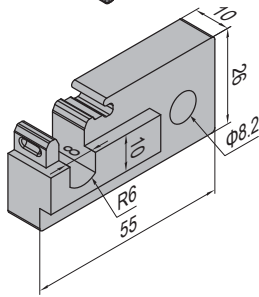

End Cap

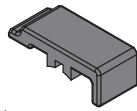

Right

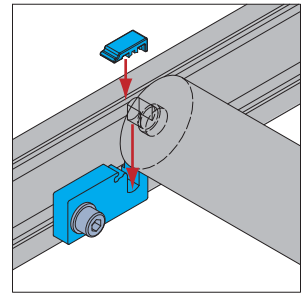
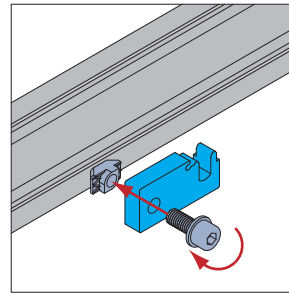
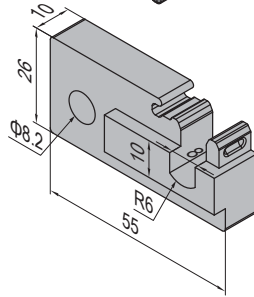

Mounting Adaptor for Roller-B

End Cap

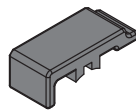

Left

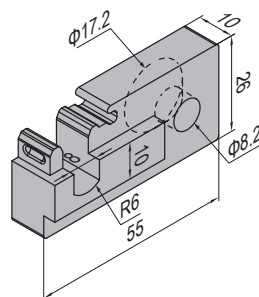



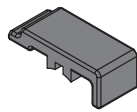

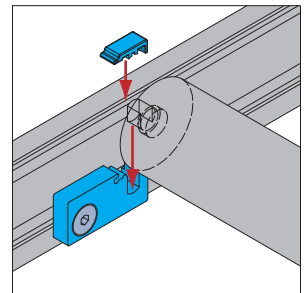
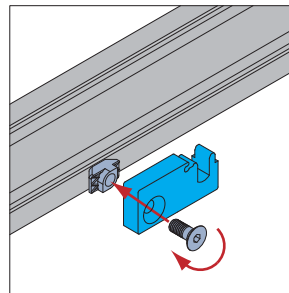
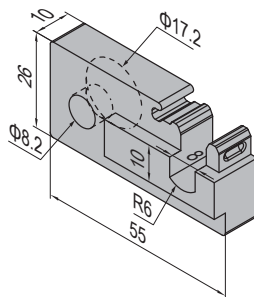

End Cap



Right



Description	Fastening Set	End Cap	Mass (g)	Part No.
Mounting Adaptor for Roller-A-Left+Right (pcs)		2	200	8.51.01A
Mounting Adaptor for Roller-A-Left+Right (set)	2xD		242	8.51.01A.ST
Mounting Adaptor for Roller-B-Left+Right (pcs)		2	194	8.51.01B
Mounting Adaptor for Roller-B-Left+Right (set)	2xFQ		226	8.51.01B.ST

D	Fastening Set	FQ	Fastening Set
	M8x20 Bolt zinc plated		M8x20 Bolt zinc plated
	M8 Washer zinc plated		M8 Washer zinc plated
	M8 T Nut nickel plated		M8 T Nut nickel plated

Additional Accessories

Telescope Unit

Telescope Unit are composed of strut profile, telescopic profile and connecting elements, the stroke of telescope unit is 50-500mm.



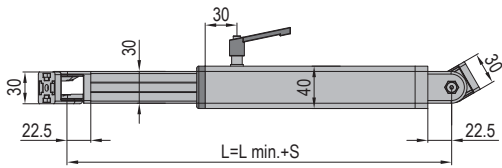

Telescope Unit-3030

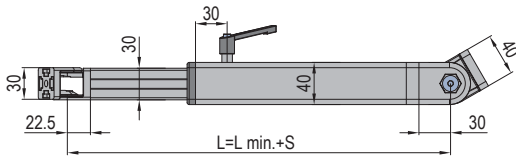

Telescope Unit-3040



Description	Fastening Set	Stroke S(mm)	L min. (mm)	Mass (kg)	Part No.
Telescope Unit-3030 (set)	2xFS	50≤S≤200	369	1.23	8.61.40.3030.01.ST
	2xFS	200<S≤350	519	1.43	8.61.40.3030.02.ST
	2xFS	350<S≤500	669	1.94	8.61.40.3030.03.ST
Telescope Unit-3040 (set)	1xFS+1xFU	50≤S≤200	377	1.42	8.61.40.3040.01.ST
	1xFS+1xFU	200<S≤350	527	1.62	8.61.40.3040.02.ST
	1xFS+1xFU	350<S≤500	677	2.13	8.61.40.3040.03.ST

FS	Fastening Set	FU	Fastening Set
	M6x10 Bolt zinc plated		M8x12 Bolt zinc plated
	M6 T Nut nickel plated		M8 T Nut nickel plated

Note: Offer per set. If there is any special requirement on the stroke, please contact with us.

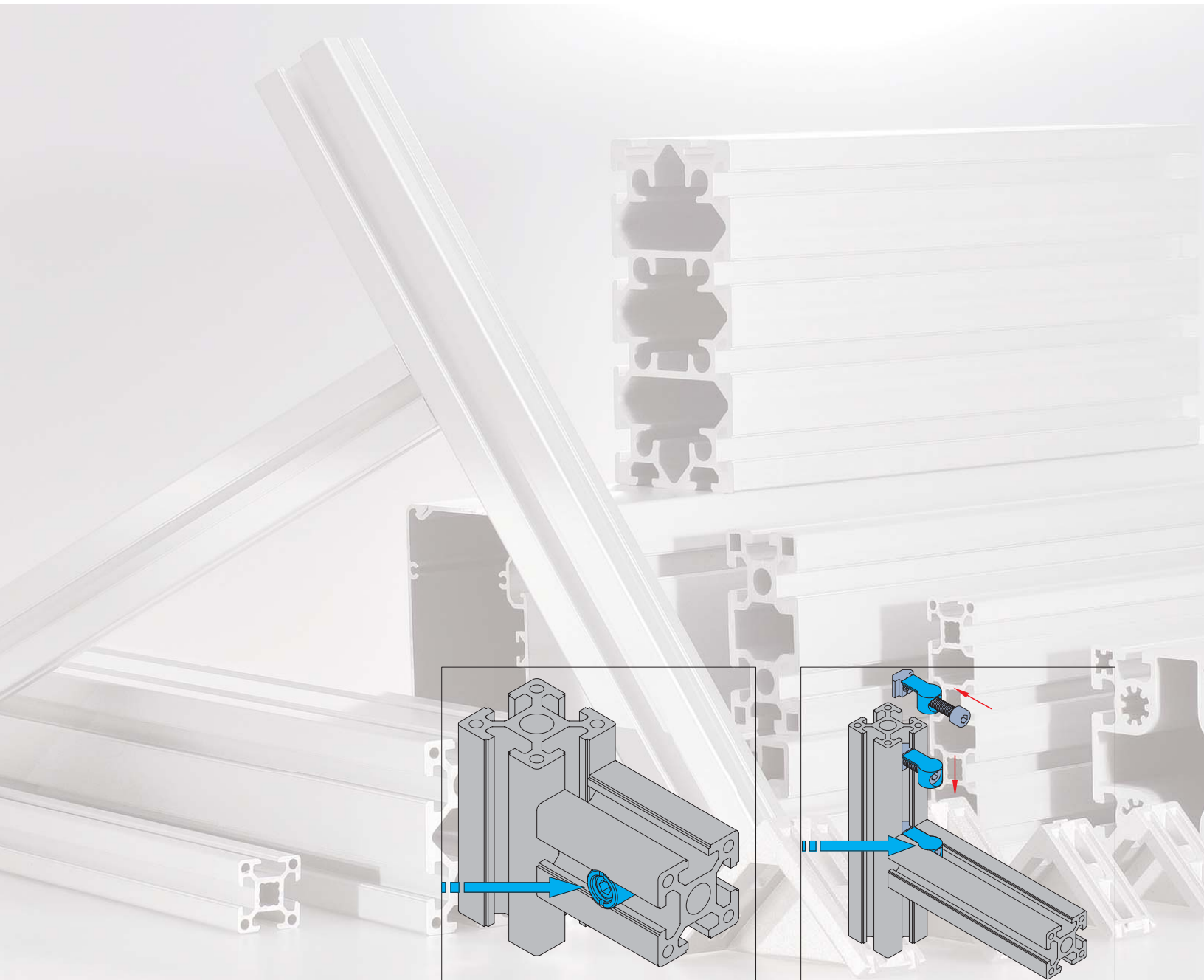

Profile Machining Code



Profile machining code

Bore sort

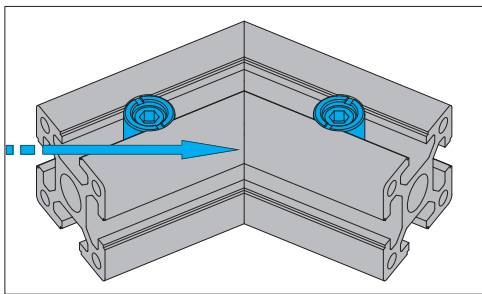
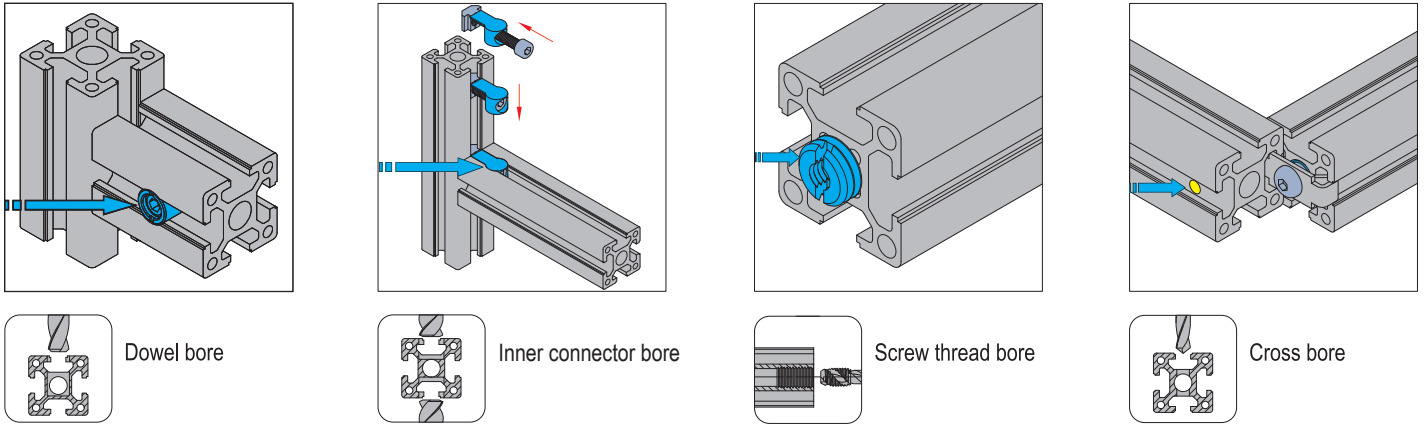

Notes

- Specify machining code when ordering.
- Refer to drawings for non-standard machining

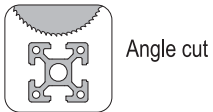

Machining name	Application
Dowel bore	Anchor Connector
Inner connector bore	Butt Connector
Screw thread bore	Screw Connector
Cross bore	Screw Connector/End Connector
Angle cut T	Anchor Connector

Code meanings		
First	Second	third
L (left) R (right)	D (Dowel bore)	H (horizontal) V (vertical) P (h+v)
	I (Inner connector bore)	
	S (Screw thread bore)	
	C (Cross bore)	
	(A B C D)T (Angle cut)	30 45 60 (angle)

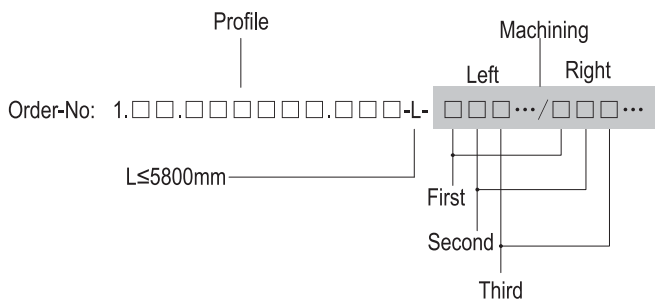





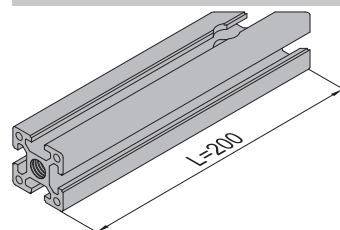



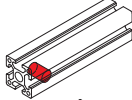
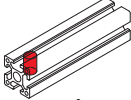
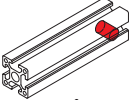
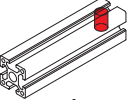
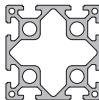
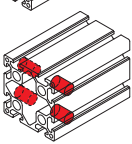
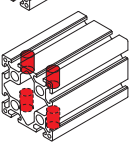
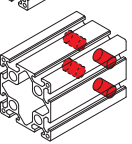
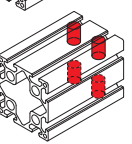

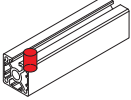
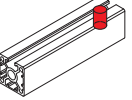
Order Example:

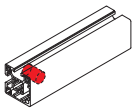
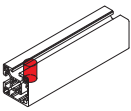
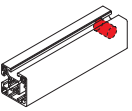
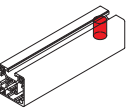
1.11.40.040040.04H-200-LSP/RBT45-RDV

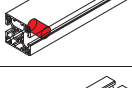
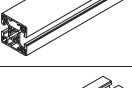

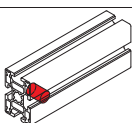
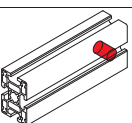
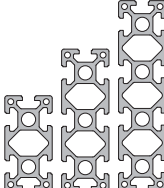
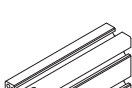
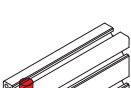
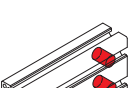
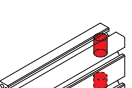
Dowel bore

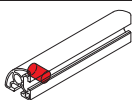
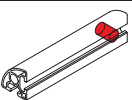
Classification		Dowel bore			
		Left		Right	
		Horizontal	Vertical	Horizontal	Vertical
Code		LDH	LDV	RDH	RDV
Square					
					
		—		—	
					
			—		—
Rectangle			—		—
					
Arc			—		—

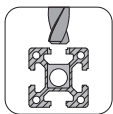



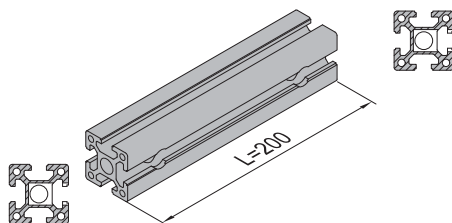



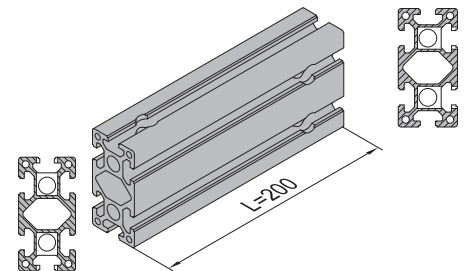



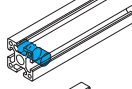
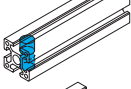
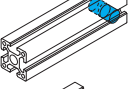
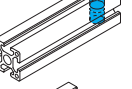

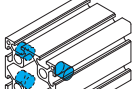
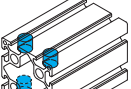
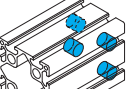
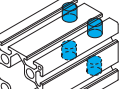

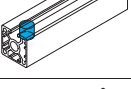

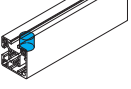
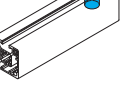
Example A : 1. 11. 40.040040.04H-200-LDH/RDH

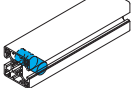
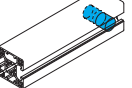

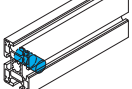
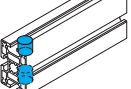
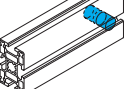
Example B : 1. 11. 40.040080.06H-200-LDV/RDH

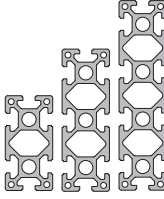
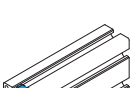
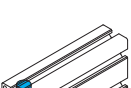
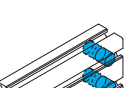
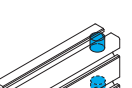

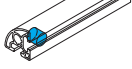
Inner connector bore

Classification		Inner connector bore			
		Left		Right	
		Horizontal	Vertical	Horizontal	Vertical
Code		LIH	LIV	RIH	RIV
Square					
					
		—		—	
		—		—	
			—		—
Rectangle					
					
Arc			—		—

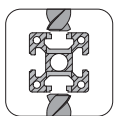



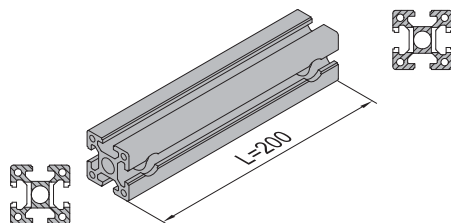



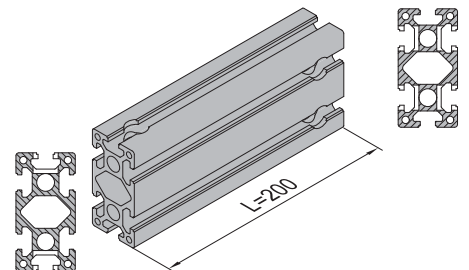



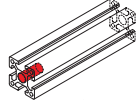
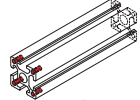
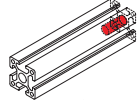
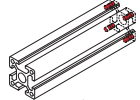
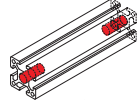
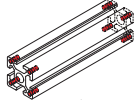

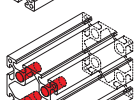
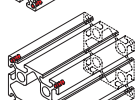
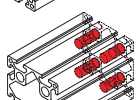
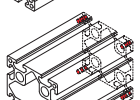
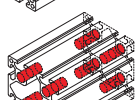
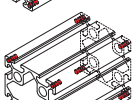
Example A: 1. 11. 40.040040.04H-200-LIH/RIH

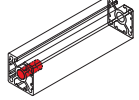
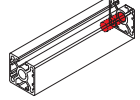
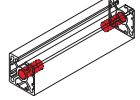

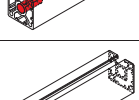
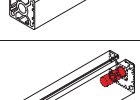
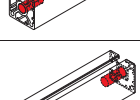
Example B: 1. 11. 40.040080.06H-200-LIV/RIH

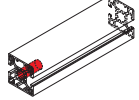
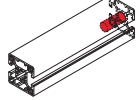
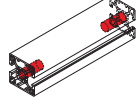

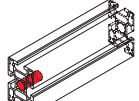
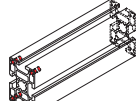
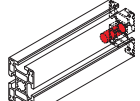
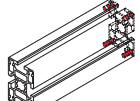
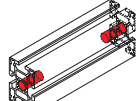
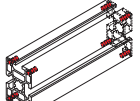
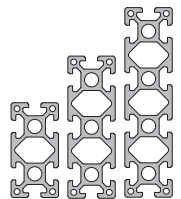
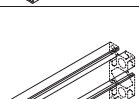
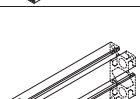
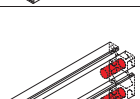
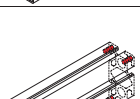
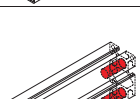
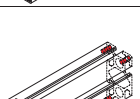
Screw thread bore

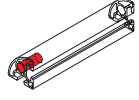
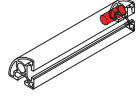
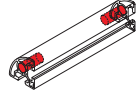
Classification		Screw thread bore					
		Left		Right		Left+ Right	
Code		LSP	LMP	RSP	RMP	WSP	WMP
Square							
							
			---		---		---
			---		---		---
			---		---		---
Rectangle							
							
Arc			---		---		---

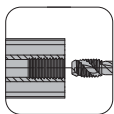

Standard:depth=22mm

Example A:

1. 11. 40.040040.04H-200-LSP

Example B:

1. 11. 40.040080.06H-200-WSP

Example C:

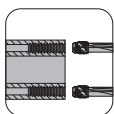

1. 11. 40.040040.04H-200-LMP

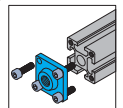
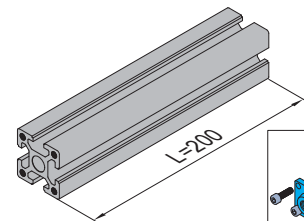
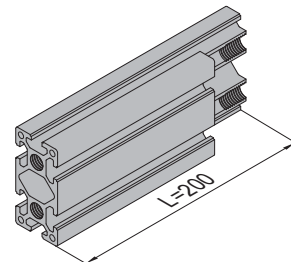
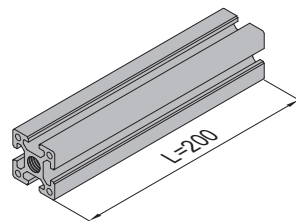

Standard:depth=22mm

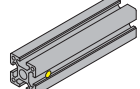
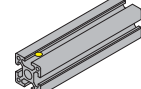
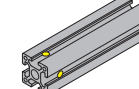
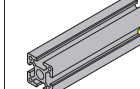
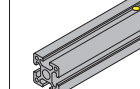
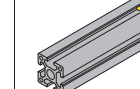
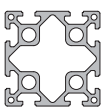
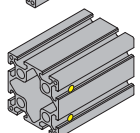
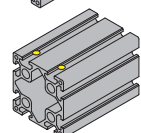
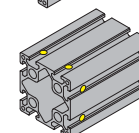
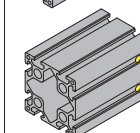
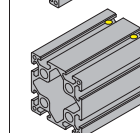
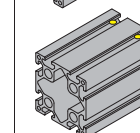
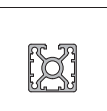
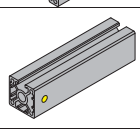
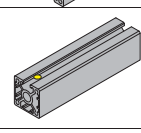
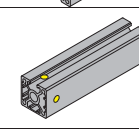
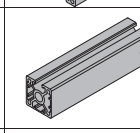
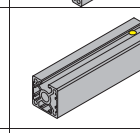
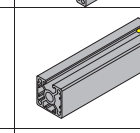
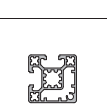
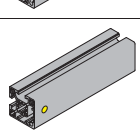
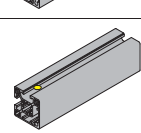
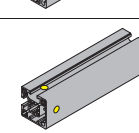
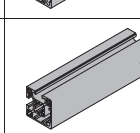
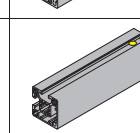
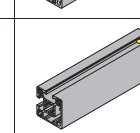
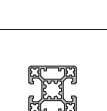
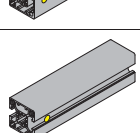
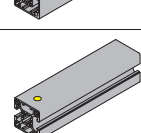
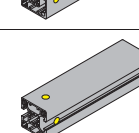
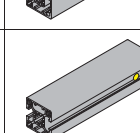
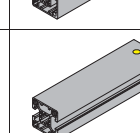
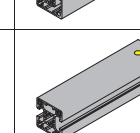

Cross bore

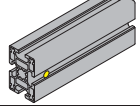
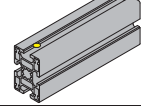
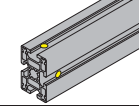
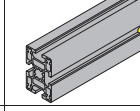
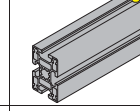
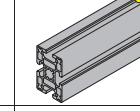
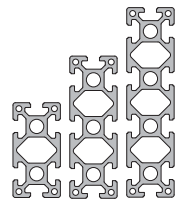
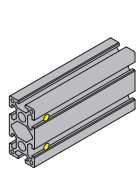
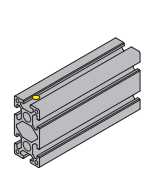
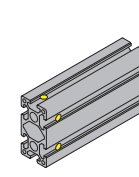
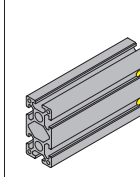
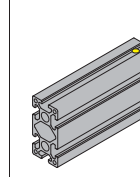
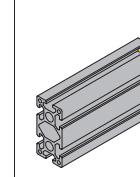
Classification		Cross bore					
		Left			Right		
Code		Horizontal	Vertical	H+V	Horizontal	Vertical	H+V
		LCH	LCV	LCP	RCH	RCV	RCP
Square							
							
							
							
							
Rectangle							
							

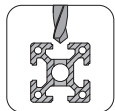

Specified crossing bore code



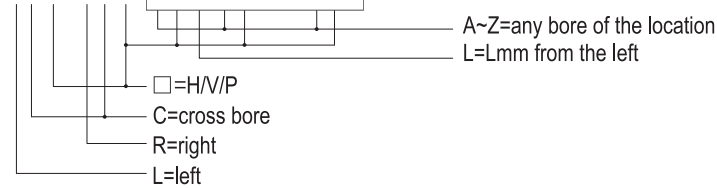



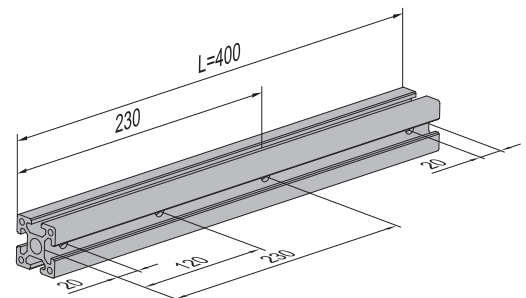

LC□/□**RC**□-**A**□**L**-**B**□**L**-...**Z**□**L**

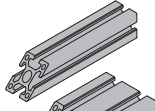
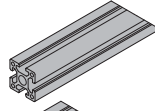
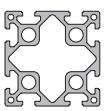
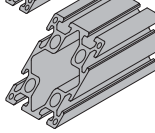
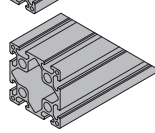

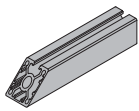
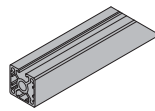
Example: 1. 11. 40.040040.04H-400-LCH/RCH-AH120-BP230

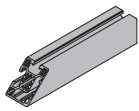
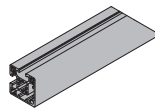

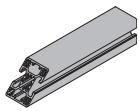
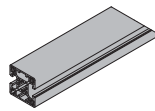
Angle cut

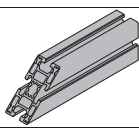
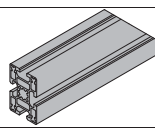
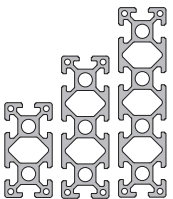
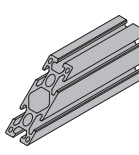
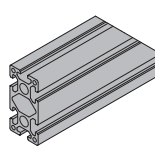
Classification		Angle cut	
		Left	Right
Code		LCT(LAT,LBT,LDT)	RCT(RAT,RBT,RDT)
Square			
			
			
			
			
Rectangle			
			

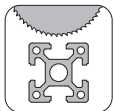

Specified cutting angle code

L□Tα:



R□Tα:

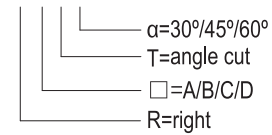

Example: 1. 11. 40.040080.06H-300-LDT45/RDT45

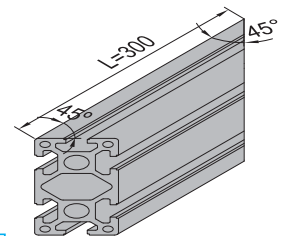

□=A向

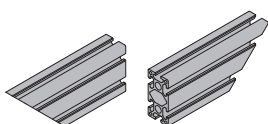

□=B向

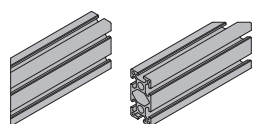

□=C向

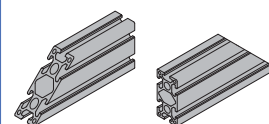

□=D向

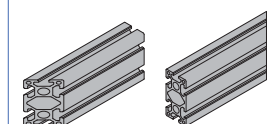



 **800-MODULAR**

 **www.moduasm.mx**

 **info@moduasm.mx**



TIJUANA • MEXICALI • HERMOSILLO • NOGALES • CD. JUÁREZ • CHIHUAHUA • MONTERREY

AGUASCALIENTES • GUADALAJARA • SILAO • LEÓN • QUERÉTARO • CIUDAD DE MÉXICO



Modular Assembly Technology Co., Ltd.
Modular Aluminio Estructural S.A. de C.V.

Mexico Headquarter: Av. Circuito de las Misiones Norte 172-L, Mexicali B.C. 21394

Tel: 01 800 MODULAR
Tel: +52 686 564 3131
Email: info@moduasm.mx (Headquarters)
ventas@moduasm.mx (Sales)
Web: www.moduasm.mx



Modular Assembly System

We reserve the right to update our product specifications without any notice and obligations, please find the latest catalogue from our website or contact us at info@moduasm.mx

